



SUSTAINABLE URBAN SITE DESIGN MANUAL



Prepared for:
NYC Department of Design & Construction Office
of Sustainable Design by

Gruzen Samton Architects LLP with
Mathews Nielsen Landscape Architects PC

June 2008

A photograph of a modern building courtyard. The foreground features a paved area with large, irregular, light-colored stone tiles. To the right, there is a gravel bed with several young, thin trees supported by black stakes. In the background, a multi-story building with large windows and a brick facade is visible. A dark green text box is overlaid on the image, containing white text.

The Sustainable Urban Site Design Manual offers an introduction to more environmentally, economically, and socially responsible urban site design practices for New York City capital projects. It is conceived as a resource handbook, featuring chapters that marry the unique site conditions encountered on many City projects with appropriate sustainable site design strategies. The contents are addressed to the whole rainbow of NYC DDC project participants, from City administrators to architects and their consultants, to construction managers, contractors, and facility personnel.

EXECUTIVE ACKNOWLEDGEMENTS

Honorable

Michael R. Bloomberg
Mayor, City of New York

David Burney, FAIA

Commissioner, NYC Department of Design and Construction

DDC Architecture and Engineering Division:

David Resnick, AIA, Deputy Commissioner, Structures Division

Margot A. Woolley, AIA, Assistant Commissioner

John Kriebel, RA, Director, Office of Sustainable Design

Bruce Hendler, RLA Chief of Landscape Architecture

Kerry Carnahan, Office of Sustainable Design

SUSTAINABLE URBAN SITE DESIGN MANUAL

TABLE OF CONTENTS

1. Overview	page
Introduction	1
NYC Environmental Challenges	2
Climate Change and the Future	4
2. Sustainable Sites for DDC	
Relevance to NYC Department of Design and Construction	9
DDC Site Design Types	10
This is What I Have, so Now What?	12
Sustainable Urban Site Planning	14
How to Use This Manual	18
3. Maximize Vegetation	
Issues and Benefits	19
Laws, Rules and Regulations	21
LEED™ and Vegetation	22
Key Issues of Planting in NYC	22
Techniques for Maximizing Plant Benefits	29
Resources	42
4. Minimize Site Disturbance	
Issues and Benefits	47
Laws, Rules and Regulations	48
LEED™ and Site Disturbance	51
Key Issues in Minimizing Site Disturbance	51
Techniques for Minimizing Site Disturbance	55
Resources	67
Understanding Soils	68
5. Water Management on Urban Sites	
Issues and Benefits	75
Laws, Rules and Regulations	76
LEED™ and Water Management	78
Stormwater Management – Key Issues	78
Techniques for Stormwater Management	81
Water Efficient Landscaping – Key Issues	97
Techniques for Water Efficient Landscaping	97
Resources	100
6. Materials in Site & Landscape Design	
Issues and Benefits	105
Laws, Rules and Regulations	107
LEED™ and Site Materials	109
Light-colored Paving and Hardscape	109
Strategies for Incorporating Recycled Materials	111
Specific Techniques and Recycled Materials	113
Resources	124

Planted Roofs: See Separate Document

Please see DDC Cool & Green Roofing Manual available on DDC's Sustainable Design website



OVERVIEW

OVERVIEW

In recent years, New York City's population and need for public facilities has grown considerably, and is expected to continue to grow. NYC Department of City Planning projects New York City will grow by more than 200,000 by 2010, and the City's population will surge past nine million by 2030. Though the City and its population will continue to grow, its land mass will not – meaning building sites will increasingly be at a premium, and the need to design them intelligently will become paramount.

Additionally, with increasing frequency, the City will need to use less desirable sites – some with significant environmental constraints - or re-use available sites.

On behalf of nearly all other New York City agencies, the Department of Design and Construction (DDC) serves as de facto Project Design and Construction Manager. In this capacity, DDC works with a portfolio of publicly-owned property. In this densely populated urban area, each acre of this property is a public treasure. When buildings are constructed, DDC strives to manage their sites to meet functional needs, make the most of their unique environmental features and protect them for the benefit of New Yorkers. With an average annual building construction/renovation budget of approximately \$500 million, DDC's goal is to approach each project as an opportunity to demonstrate sustainable practices, and to address the myriad environmental challenges of building in the city.

This manual addresses landscape opportunities associated with building projects. It was developed for the Structures division of DDC, the group that manages the design and construction of City buildings. The document highlights sustainable site design practices for their Project Managers and Consultants – and it does so by focusing on practical recommendations for site land uses, controlling site disturbances, managing stormwater and other hydrological resources, and landscape planting. In turn, these recommendations are linked to site typologies common to DDC building sites – and possibly to a broader City audience, as NYC modifies its practices in line with the goals of PlaNYC 2030.

It is important to note that there is a companion manual developed for the Infrastructure division of DDC, a separate group that manages design and construction of streetscape and public right of way projects. *High Performance Infrastructure Guidelines* was prepared in 2005 with the Design Trust for Public Space. This handbook presents Best Management Practices, practical strategies and technical resources for sidewalks, roadways, utility projects – and their adjacent landscaped areas. The scope is different and the site issues broader, but the goal of both handbooks is to help project teams achieve greener results. *High Performance Infrastructure Guidelines* is available on-line at <http://www.nyc.gov/html/ddc/html/ddcgreen/documents/hpig.pdf>



photo: Mathews Nielsen Landscape Architects

NYC ENVIRONMENTAL CHALLENGES

Good site design in New York City requires an understanding of the City's unique conditions and environmental challenges. The same factors that make NY energy-efficient – e.g. density, public transportation, extensive infrastructure – make it unsuitable for many typical site planning and landscaping strategies. Strategies must be tailored to the City's climate conditions, such as cold winters and intense rainfall events. Often it is not environmental criteria that determine a building's orientation and placement on a site, but the street grid, site shape and zoning. Access options are frequently limited. Open areas, otherwise suitable for planting, may be shaded by neighboring buildings.

However, with ingenuity and careful planning, site design can be instrumental in improving the comprehensive environmental performance of projects, as well as enhancing and restoring urban ecological systems. DDC strives to encourage site design strategies that not only create beautiful, healthful properties, but also help to address citywide environmental issues. A summary of these key challenges follows.

Climate Change: The New York area has already experienced warmer, more unpredictable weather and rising sea levels. Anticipated impacts from natural forces affected by climate change include longer periods of heat, drought, more frequent and severe storms, loss of coastal wetlands, beach and soil erosion, increased localized flooding and water quality degradation. Without action, impacts will continue to intensify. This manual explores site-related strategies that can help mitigate some of these conditions.

Urban Heat Island (UHI): Cities are as much as 5 to 10 degrees hotter than the surrounding countryside. This phenomenon, known as the Urban Heat Island effect, results from several factors, including the relative dearth of vegetation in cities, the preponderance of heat-absorbing dark roofs and paving materials on roads and parking areas, and the accumulation of hot exhaust gases and engine heat from cars, trucks and buses. These dark surfaces and lack of vegetation work together to compound the problem: the dark surfaces absorb the heat, and the lack of vegetation limits the natural cooling that the shade of living plants provide.



Areas devoid of vegetation (map right) indicate the areas of warmer temperatures (map on the left)

Photo: NASA

The UHI effect damages the environment in a number of ways. Higher urban temperatures increase the demand for air conditioning, resulting in higher energy consumption and power plant emissions. When it is hottest, air conditioners consume much more energy, causing a corresponding increase in the heat they discharge (rejected heat), which further raises urban temperatures. A hotter City means more air pollution, because older, less efficient power plants are needed for energy production at peak times, and ground level ozone is more easily produced at higher temperatures. More heat also means more water use for infrastructure, landscaping and personal use.

Combined Sanitary / Stormwater Sewer System: New York City is surrounded by water, and its adjacent rivers and water bodies are particularly vulnerable to both local and regional pollution. Despite major gains in its water quality over the past few decades, New York City still faces a critical hurdle; approximately 70% of the City's 6,300 mile sewer system consists of combined sanitary and stormwater sewers. These combined sewers become overwhelmed during intense rainfalls, and 27 billion gallons of "combined sewer overflows" (CSOs) are discharged into the City's receiving waters each year. The strategies contained within this document can help reduce, control, and treat stormwater runoff as close to its source as possible so that CSO events and their polluting effects are minimized.

Water Supply: Conserving water within open spaces and planted areas is as important as controlling flow off-site. New York City relies on over 1.1 billion gallons of water per day supplied from upstate reservoirs; water conservation is a crucial objective to ensure the long-term viability and supply of our high-quality water.

Density and Limited Land: New York City is the densest U.S. city, averaging approximately 27,000 people per square mile. Consequently, buildable land often comes in small parcels, on which the building occupies most of the site. While there is City-owned land in parks and open areas, most of the projects DDC develops and manages on behalf of other City agencies are located in urban neighborhoods. In these circumstances, environmental site planning requires a neighborhood approach. When every property has a little bit of open land, significant benefits are gained when those little bits are linked together to create one continuous, usable open space. Continuity and connectivity form natural networks that support biodiversity, wildlife habitats, soil remediation and provide hydrologic benefits. Even on the most developed site, where every trace of nature seems to have been obliterated, fragments of land can be joined so that natural systems can be re-introduced and encouraged. This manual suggests some techniques useful for small, limited parcels. (Another DDC document, *Cool and Green Roofing Manual*, discusses rooftops as potential urban open spaces.)



courtesy: Metropolitan Waterfront Alliance

Combined sanitary/stormwater sewer outfall

Hostile Plant Environment: The urban environment is stressful for trees and plants. Air pollution, limited space for root development, poor and compacted soils, physical hazards from people, vehicles, dogs and bikes, physiological threats from pests, and limited sunlight and water contribute to the difficult environment in which urban plants try to thrive. Identifying strategies that optimize the viability and survival of plants and trees is critical to our City's future. This manual offers sustainable planting techniques to maximize all types of vegetation including recommendations for soil testing, soil types, root space requirements, spacing and suggested plant lists for different conditions.

Less than Optimal Soils: Getting trees and plants to grow in New York City is a challenge. Two of the most significant obstacles to plant growth are small soil volume and compaction caused by competition for root space with utilities and other subsurface appurtenances, and the weight of pavement and constant traffic, which lead to poor soil aeration and drainage. Under these conditions, trees and plants simply stop growing and become more susceptible to drought, pests and diseases. Soil compaction leads to stunted, drought-stressed plants due to low oxygen concentration, decreased rooting volume, and moisture irregularity. Compacted soils have lower infiltration rates than undisturbed soils and are more prone to erosion and sedimentation. On some sites the soil is further compromised by contaminants, such as acids and lime, resulting from poor construction and building maintenance practices, and in some cases the illegal dumping of hazardous chemicals.



photo: Mathews Nielsen Landscape Architects

Inadequate space for root development

An Underground City: In New York City, just as we build “up” within the bounds of our limited space, we also build “down.” Subways, tunnels, utilities, communications cables, and water pipes, all exist below street level in a complicated, dynamic network. Despite the myriad advantages to building underground, a complex subsurface condition can create significant site planning and design constraints for architects and landscape architects developing projects on the surface. Given the age and vulnerability of NYC’s sewer and water lines to vibrations and tree roots, and the potential for construction-related damage, it is imperative to know what’s under the surface of your site (and adjacent) in order to avoid damaging critical infrastructure. For this reason, projects are subject to regulations and review by many City agencies, particularly the Department of Environmental Protection.



photo: Mathews Nielsen Landscape Architects

Subsurface utilities limit tree planting

CLIMATE CHANGE AND THE FUTURE

The following text is quoted from *Inventory of New York City Greenhouse Gas Emissions, April 2007*:

The term “global climate change” refers to the destabilizing impact on climate and weather patterns that result from continuous addition of greenhouse gases, the resultant increase in heat energy in the earth’s atmosphere, and the associated changes that follow. Even small changes in the average temperatures can be accompanied by an increase in severe weather events such as storms and droughts, ecosystem change, loss of animal and plant species, stresses to human health, and alterations in regional agricultural productivity.

Although climate change is a global issue, the effects of rapidly rising temperatures will be felt in every local community. Average temperatures in New York State are projected to increase between 2°F and 8°F by 2100, with the largest increases in coastal regions such as New York City. Average precipitation is also expected to rise by 10 to 20 percent, with extreme wet and snowy days becoming more frequent. Intense weather trends will be felt on the opposite end of the temperature spectrum, as the occurrence of summer days with temperatures above 90° are expected to multiply from 14 days in 1997-1998 to 40-89 days by the 2080s.

The list of threats associated with global climate change is alarmingly long, and encompasses effects on air, water, and vegetation. Certainly not all of them can be addressed within the context of individual projects, but site designers should recognize potential impacts and design to help mitigate them. The site strategies offered in this manual take into account pertinent considerations for ecosystem health, water supply and quality, and the Urban Heat Island effect.

PlaNYC 2030, the City’s strategy for making our city better, more green and more livable, attempts to reduce NYC’s global warming emissions by 30% with city-wide initiatives that address policy and infrastructure, and encourage individual building projects to do their part.

CLIMATE CHANGE AND ECOSYSTEMS

The effects of climate change on biodiversity and ecosystems are impossible to separate from the effects of other stresses, such as pollution, atmospheric levels of carbon dioxide, land management and use trends. To date there is no conclusive evidence that climate change alone will have an adverse impact on the survival of plant and animal habitats. There are examples that many scientists attribute to global warming, such as the fact that flowering plants are blooming about 5 days earlier per decade, birds are laying eggs sooner, and maple syrup production from sugar maples has shifted from northern New England to Canada.

In general, global warming has caused the slowly creeping polar migration (northerly for the U.S.) of a plant or animal’s habitat. Thus climate change could benefit certain plant or insect species by increasing their ranges. The resulting impacts, however, could be positive or negative depending on whether these species are invasive. For example, climate change could have potentially devastating

impacts on agriculture and forests if pest species are decoupled from their controlling prey, or if the ranges of animals responsible for seed dispersal become disjointed.

Climate change will affect individual wetland ecosystems largely through changes in precipitation, erosion, rising sea level, and temperature fluctuations. Wetland plants and fauna are extremely sensitive, such that even minor variability of moisture storage can adversely affect plant and animal diversity and microbial activity.

In New York, as well as in other parts of the country, the Climate Zone classification for plant hardiness has shifted, increasing in NYC from 6A (minimum temperature -10° F) to 6B (minimum temperature -5° F). This is good news from the standpoint of broadening the range of plant material that can survive NYC winters. However, plants like poison ivy become more toxic, ragweed produces more pollen, and Northeastern urban forests may soon have to contend with Kudzu, which has swallowed whole woodlands in the South.

CLIMATE CHANGE AND WATER

As a coastal city, New York is particularly susceptible to the effects of global climate change. Rising sea levels and higher risk of severe floods and storms pose a potentially devastating threat to sites located within floodplains and sites with deteriorated shorelines. Sea levels along much of the New York coast have been rising at an average of $\frac{1}{4}$ inch per year. If this trend continues, within the next 75 years sea levels surrounding New York will have risen more than 18 inches. Such a rise would result in complete inundation of areas currently mapped within the 100-year floodplain. Other serious degradation would occur in coastal wetlands, beaches, fresh water lakes and rivers. The statistical probability of a “100-year storm” has already become a once in 80 year event and may progress to a once-in-43 year event by 2020 and by 2050, a once-in-19 year event. Looking ahead, DDC will be taking a more critical look at sites and building locations near the water and flood plain, recognizing that the effective limits of the 100-year flood plain are likely to expand. For updated maps of flood-prone areas in New York City, see the NYC Department of Buildings (DOB) Flood Insurance Rate Maps 2007 on the DOB website.

DEP’s Climate Change Program published its *Assessment and Action Plan* in May 2008. In this report, NYCDEP Commissioner Emily Lloyd states: “The impacts of climate change will be pervasive and profound. Most natural and man-made systems will be affected, and the City of New York’s water supply, drainage, and wastewater management systems are no exception . . . the time to take action is now.”

The City’s water system could be affected by increased evaporation of water due to warmer temperatures, which would reduce river flows and lower lake and reservoir levels, particularly in summer when demand for water is at its highest. Higher temperatures and more violent storms could lead to increased turbidity of reservoirs thereby decreasing water quality.

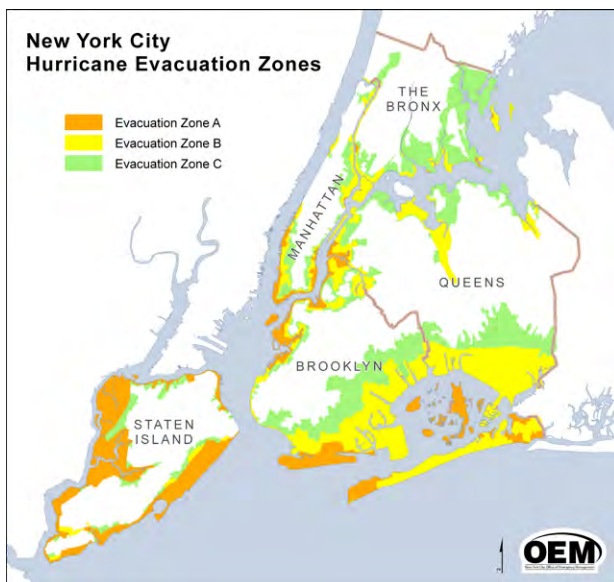

More severe and frequent rainfalls will exacerbate combined sewer overflows (CSOs), causing greater pollution of surrounding rivers and estuaries. In New York City, the prevention of combined sewer overflows is already a priority, and there are detention regulations that cover all areas with constrained sewer capacity. Site and landscape strategies include increasing permeable surfaces, employing bio-retention, and capturing rainwater for reuse. Specific planning and design techniques are discussed in the Stormwater Management chapter, with diagrams and details of practices.

NEW YORK AS AN URBAN HEAT ISLAND

As global and local temperatures rise, mitigation of the Urban Heat Island (UHI) effect will become critical in NYC, as an increase of air temperature of only 6° to 8° F can trigger a range of public health problems, particularly for children, the elderly and people with respiratory ailments. Also, since NYC chronically faces shortfalls of electrical capacity at peak demand, the UHI effect increase the risk of brown-outs or black-outs.

More vegetation, especially trees, is a key remedial approach for site and landscape architects seeking to minimize the UHI effect. Plants provide natural cooling in several ways –by providing shade, by utilizing the sun’s energy in photosynthesis, and, most importantly, by evapotranspiration, which is similar to perspiration. When plants transpire, they turn water into vapor, dissipating the latent heat of vaporization and providing cooling.

Though studies (see below) have shown vegetation plays a more important role in UHI mitigation than light colored surfaces and other physical factors (height, orientation to prevailing winds etc.), these strategies are synergistic when combined with planting. Planting – along streets, in open areas and on rooftops – combined with other strategies, such as replacing dark surfaces with lighter colored ones, offers more potential cooling than any other individual site design measure.

NYSERDA, with Columbia University Center for Climate Systems Research & NASA Goddard Institute for Space Studies, Hunter College Department of Geography, and the Science Applications International Corp., sponsored a study in October 2006 of NYC’s heat island and ways to mitigate it, entitled *Mitigating New York City’s Heat Island with Urban Forestry, Living Roofs, and Light Surfaces*.

Effective city-wide mitigation strategies – identified by NYSERDA in descending order of individual effectiveness as street trees, living roofs, light-colored surfaces and open space planting – can and should be used together when possible for DDC projects. Site design and construction strategies that work to maximize cooling are given special attention in this manual.

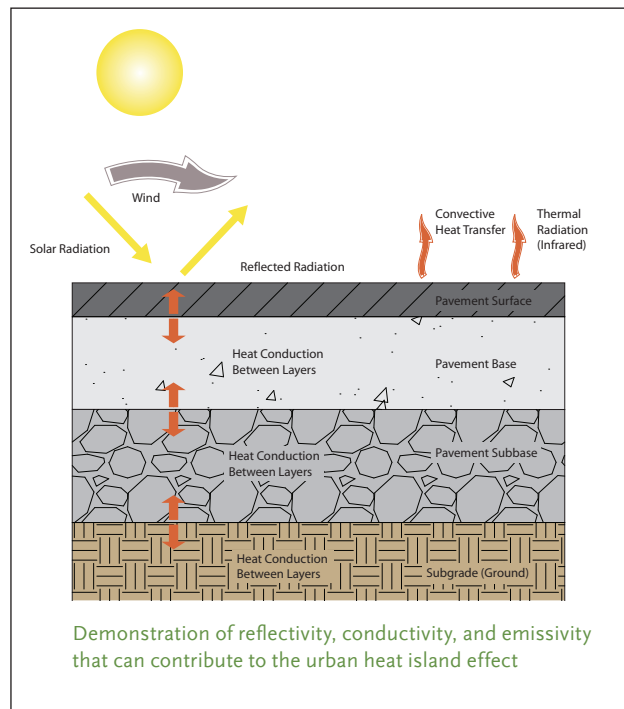

URBAN HEAT ISLAND STRATEGIES FOR DDC

STRATEGY	MITIGATION SCENARIO	REFERENCE
Use light colored surfaces	<ul style="list-style-type: none"> · Use light colored pavement (high albedo) · Use light roof surfaces 	<ul style="list-style-type: none"> · See DDC Cool & Green Roofing Manual · See Light Colored Paving in Materials chapter
Maximize vegetation - Landscape	<ul style="list-style-type: none"> · Plant street trees · Plant trees in open spaces and sidewalks · Maximize other planting and minimize hardscape · Use open-grid paving techniques 	<ul style="list-style-type: none"> · See Maximize Vegetation chapter
Maximize vegetation - Living Roof	<ul style="list-style-type: none"> · Use green roof technology 	<ul style="list-style-type: none"> · See DDC document Cool & Green Roofs
Provide Shade	<ul style="list-style-type: none"> · Plant trees · Use green screens, other plantings · Locate paved areas in building shadow, under overhangs etc. 	<ul style="list-style-type: none"> · See Maximize Vegetation chapter
Use porous pavement	<ul style="list-style-type: none"> · Minimize heat storage through use of porous pavements 	<ul style="list-style-type: none"> · See Stormwater Management chapter

RESOURCES

CLIMATE CHANGE

- PlaNYC 2030 *A Greener, Greater New York*, Mayor's Office of Long Term Planning and Sustainability, May 2007 <http://www.nyc.gov/html/planyc2030/html/home/home.shtml>
- *Inventory of New York City Greenhouse Gas Emissions*, Mayor's Office of Long-term Planning and Sustainability, April 2007 http://www.environmentaldefense.org/documents/493_HotNY.pdf
- Climate Change Program Assessment and Action Plan, NYC Department of Environmental Protection, May 2008 http://www.nyc.gov/html/dep/pdf/climate/climate_complete.pdf
- Global Warming & Rising Oceans: www.actionbioscience.org
- Climate Change 2001: Impacts, Adaptation and Vulnerability www.grida.no
- Ecosystems and Biodiversity <http://www.epa.gov/climatechange/effects/eco.html>
- Effects of Global Warming <http://news-service.stanford.edu/pr/o3/root18.html>
- "A Wetlands Climate Change Impact Assessment for the Metropolitan East Coast Region": www.metroeast_climate.ciesin.columbia.edu/reports/wetlands.pdf
- "Impacts of sea level rise in the New York City metropolitan area" by Vivien Gornitz, Stephen Couch and Ellen Hartig, *Global and Planetary Changes*, Vol. 32, 2002

URBAN HEAT ISLAND EFFECT

- Mitigating New York City's Heat Island with Urban Forestry, Living Roofs, and Light Surfaces, NYSERDA, October 2006
- "Cooling the Blacktop" by Meg Calkins. *Landscape Architecture Magazine*, pp 53- 61. February 2007.
- US EPA Heat Island Reduction Initiative: www.EPA.gov/heat_island/strategies/index.html
- "Features Favored by Mother Nature": www.concreteparking.org/environmental.htm
- "Heat Island Effect": <http://yosemite.epa.gov/oar/globalwarming.nsf/content/ActionsLocalHeatIslandEffect.html>
- "Air Pollution Prevention Through Urban Heat Island Mitigation": www.ghcc.msfc.nasa.gov/uhipp/epa_doc.pdf
- "Sustainable Site Design Philosophy": www.nps.gov/dsc/dsgncnstr/gpsd/ch5.html
- "Sustainable Sites: The Case for a Site-Only LEED" by Mike Abbate, The American Society of Landscape Architects and the Ladybird Johnson Wildflower Center, August 2005.
- Cool and Green Roofing Manual, NYC Department of Design and Construction, June 2007: http://www.nyc.gov/html/ddc/html/design/sustainable_home.shtml



SUSTAINABLE SITES
FOR DDC

SUSTAINABLE SITES FOR DDC

In New York City, population growth and proliferation of new buildings have increased the need for ingenuity in site planning and design to maximize the human and environmental benefits. The Department of Design and Construction and other City agencies are taking a leadership role in encouraging and supporting sustainable site design and landscaping.

All City projects are informed by PlaNYC 2030, the Mayor's April 2007 comprehensive sustainability plan for a greener, greater New York. PlaNYC targets five key dimensions of the City's environment – land, air, water, energy and transportation. The intent of this integrated approach is to help ensure a higher quality of life for future generations, and help reduce NYC's global warming emissions. Site and landscape design are an integral part of the approach and proposed initiatives - specifically those for land and open space, water quality and air quality.

With the enactment of Local Law 86 of 2005, the City now requires most of its projects to meet the Silver level of the LEED™ certification process of the U.S. Green Building Council (USGBC), as well as specific energy and water efficiency requirements. Site planning, landscaping and related material choices can contribute to possible LEED-NC credits in Sustainable Sites, Water Efficiency, Energy & Atmosphere, and Materials & Resources. Each section of this manual highlights applicable LEED™ strategies. DDC's Project Timeline for LEED/Local Law 86 of 2005 and related documents are available on the DDC's Sustainable Design website.

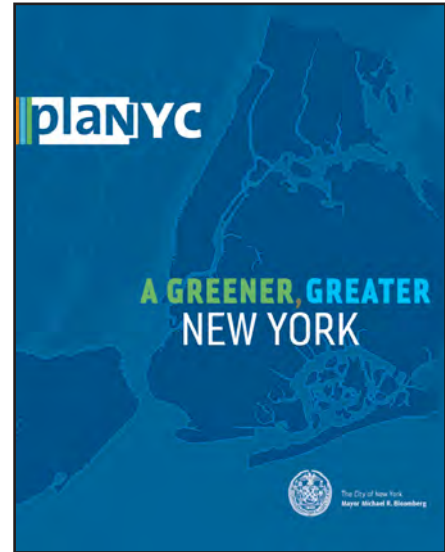

Because DDC's client base and project portfolio present an array of unique site conditions, it is impossible to offer prescriptive site design solutions here in this manual. Rather, the document is written to provide a framework for DDC project personnel to discuss and promote sustainable site design principles within their own projects, and to specifically address challenges and obstacles commonly encountered on DDC projects, such as:

- **Wide range of sites / wide range of facility types.** DDC's projects range from buildings on parkland, to police stations on tight urban lots, to childcare centers with play yards. And as the City grows, DDC is often forced to build on more problematic properties. No universal approaches will work, so this manual is organized to address the basic issues, and suggest a menu of appropriate solutions for different types of sites;
- **Agency regulations and laws.** City, State and Federal agencies hold jurisdiction over specific aspects of site design, with a complex network of regulations and laws. Applicable laws are noted in each section, with reference to more information;
- **Inexperienced consultants.** Some consultant teams are unfamiliar with sustainable site approaches. This is due either to inexperience with site/landscape technologies, and/or to the lack of a professional landscape architect on the Consultant Team. We recommend that each project have a landscape architect on the design team, and this manual is meant to augment the broader team's knowledge with specific sustainable approaches;
- **Bad timing.** Often landscape design services lag behind the building concept, whether because survey information is not available or the landscape architect does not participate in the early stages of planning and design. A sustainable site approach requires early input by the landscape architect. It is very important to note that topographic surveys and soil profile studies are available through DDC at no cost to the project, however, if they're going to help guide site design and gain approvals, they must be requested as soon as a client Agency circulates its scope;
- **Lack of coordination.** Opportunities are lost, and mistakes made when project team members do not understand the considerations of each participating discipline.

DDC SITE DESIGN TYPES

The City agencies DDC serves perform a wide variety of functions in all five boroughs; accordingly, landscape design opportunities range from open, vegetated sites to very tight urban sites. DDC is responsible for built projects in the many parks and the botanical gardens, as well as for civic buildings located within varied NYC neighborhoods, including police stations, daycare centers, courthouses and others. Most DDC projects can be characterized into one of the following typical design types:

Building on a Campus

- **Characterized by** a campus site several buildings on one property, connected by driveways, walkways, utility services and landscapes;
- **NYC Examples:** Crossroads Congregate Care Facility, Snug Harbor Cultural Center, Lion House at the Bronx Zoo, Gateway Estates;
- **Opportunities** for sustainable site design include stormwater management techniques that require large sites such as wetpools and wetlands, berms and slope reduction benches, large infiltration areas; maximize vegetation including habitat restoration, shelterbelts, and meadows; use materials that incorporate recycled content, particularly for roads, paths and parking; site protection techniques that limit construction vehicle access and staging and protect zones of existing vegetation.



Congregate Care Facility

Building in a Park

- **Characterized by** a campus site in which landscape and parkland are a priority feature. Utilities may not be readily available;
- **NYC Examples:** Queens Botanic Garden, NY Hall of Science, Central Park Precinct, Queens Museum, Hunts Point Community Center, Rose Center Planetarium;
- **Opportunities** for sustainable site design include stormwater management strategies suitable to medium scale sites, such as storage and infiltration beds integrated with parking lots, bioretention areas and pervious paving; maximize vegetation by expanding contiguous landscaped areas and creating buffers of planting to mitigate harsh climate conditions; incorporate recycled content in products such as perimeter fencing, wheel stops, pavements and pavement subbases; use site protection techniques that limit disturbance in areas to be planted, amend rather than import new planting soil, and protect soil from erosion.

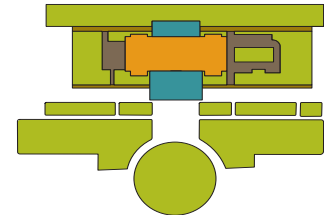

Queens Museum

Lot line Building

- **Characterized by** extremely constrained open space, frequently not more than perimeter sidewalks, a small entry plaza and perhaps a rear yard;
- **NYC Examples:** Bridges Juvenile Center, Pike Street DEP facility, Remsen Avenue DEP facility, Engine Co. 277, Lenox Hill Senior Center, 9th Precinct;
- **Opportunities** for sustainable site design include stormwater management using pervious pavements, structural soil, planters, catch basin inserts and vegetated roofs; maximize vegetation by planting street trees and planters adjacent to entry, using vine screens on appropriate walls; use materials that incorporate recycled content particularly for pavements, furnishings and green roof systems; minimize site disturbance by protecting existing street trees.

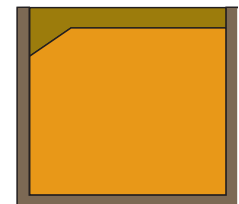

Pike Street
DEP Facility

Building with a Plaza

- **Characterized by** a paved open space accessible to the public;
- **NYC Examples:** OEM Headquarters, Aaron Davis Hall at CCNY, Brooklyn Central Library, Glen Oaks Branch Library, Bronx County Hall of Justice;
- **Opportunities** for sustainable site design include stormwater detention tanks, permeable pavement, trees to maximize shading of plaza, light-colored pavement, grey water capture and reuse for irrigation.



OEM Headquarters

Courtyard Building

- **Characterized by** a protected outdoor area, enclosed or semi-enclosed by the building. Many serve as recreation areas for the facility's users.
- **NYC Examples:** Williamsburg Community Center, Williamsburg Day Care, El Museo del Barrio, PS 1 Museum, Richmond Hill Group Home;
- **Opportunities** for sustainable site design include small scale stormwater filtration devices, using native and drought tolerant plants, use of trees to shade public plaza and west walls; use of high albedo pavements and those that contain recycled content.

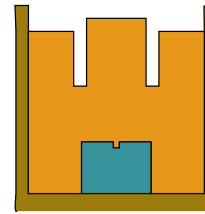

El Museo del Barrio

Building Surrounded by Parking

- **Characterized by** surface parking requirements that leave little site area for landscaping or outdoor functions;
- **NYC Examples:** Metropolitan Transportation Authority Corona Maintenance Facility, 120th and 121st Police Precincts, Queens Hospital EMS Station, Randall's Island Fire Training Facility, Rockaway Fire and EMS Station;
- **Opportunities** for sustainable site design include deploying stormwater management strategies requiring minimal site area such as rain gardens, planters catch basin inserts and infiltration swales; maximize vegetation by planting street trees, adding trees to plazas and other paved surfaces to create shade; using permeable and light-colored paving, incorporating materials that contain recycled content particularly for paving systems and site furnishings; minimize site disturbance by protecting existing trees, staging construction away from future planted areas and preventing contamination to existing soil areas.

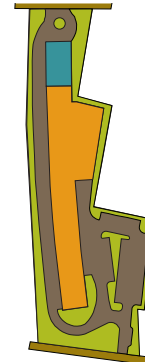

121st Precinct

Building on an Irregularly-Shaped Site

Characterized by areas of "leftover" property, and/or awkward circulation patterns;

- **NYC Examples:** Sunrise Yard Maintenance Yard, George Vierno Dormitory, Park Slope Branch Library, Ft. Hamilton Branch Library;
- **Opportunities** for sustainable site design include saving and maximizing areas of vegetation; introduce pockets of vegetation & trees; employ various stormwater management techniques; and use of materials containing recycled content. The opportunities need to be carefully evaluated based on site shape and the amount of undeveloped land after the building and site program are defined. Location of the building on site is key.

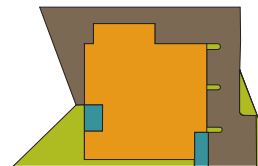

Sunrise Yard

Building Adjacent to Water

Characterized by low-lying land, typically comprised of landfill and sloping topography or constructed edge adjacent to a river or estuary;

- **NYC Examples:** Harper Street Yard on Flushing Bay;
- **Opportunities** for sustainable site design include maximizing vegetation as a strategy for shoreline restoration, wetland and filtration techniques to filter and slow stormwater runoff, various construction impact mitigation techniques, as well as others that are required by regulatory agencies.

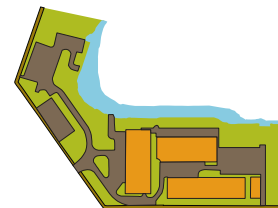

Harper Street Yard



Native plants can be used in all design types, for lower maintenance and more ecological value.

THIS IS WHAT I HAVE, NOW WHAT?

So, how does this apply to my project? Below are diagrams of the typical site types that DDC encounters, highlighting conditions common to them. Because all sites are different, review these samples to identify the site conditions that apply to your project. Relevant site and landscape strategies are listed in the chart below, showing where more information can be found in this manual.

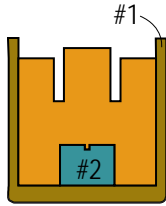

EL MUSEO DEL BARRIO
Courtyard Building

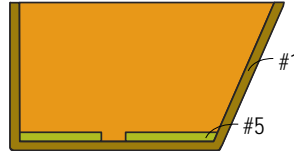

EL REMSEN AVE. DEP FACILITY
Lot Line Building

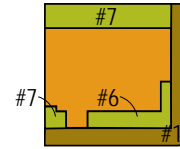

KINGS BRIDGE BRANCH LIBRARY
Lot Line Building

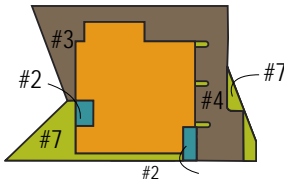

SUNRISE YARDS
Buildings on an Irregular Shaped Site

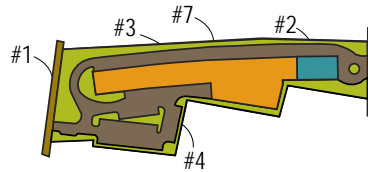

121ST PRECINCT
Buildings Surrounded by Parking

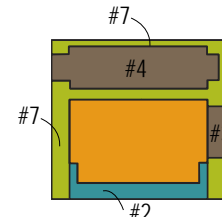

OEM HEADQUARTERS
Building with a Plaza

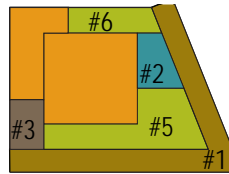

FT. HAMILTON BRANCH LIBRARY
Buildings on an Irregular Shaped Site

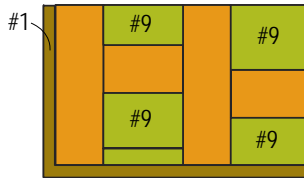

BRIDGES JUVENILE JUSTICE CENTER
Courtyard Building

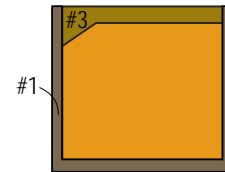

PIKE STREET DEP FACILITY
Lot Line Building

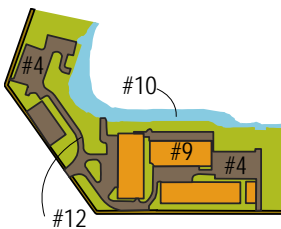

HARPER STREET YARD
Buildings Adjacent to Water

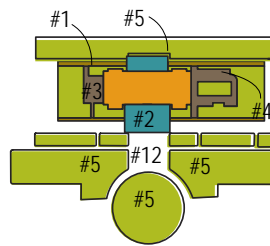

QUEENS MUSEUM
Buildings in a Park

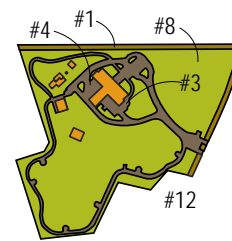

CONGREGATE CARE FACILITY
Buildings on a Campus



120th STREET PRECINCT
Buildings Surrounded by Parking



BROOKLYN CHILDREN'S MUSEUM
Buildings on an Irregular Shaped Site

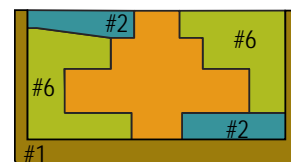

PARK SLOPE BRANCH LIBRARY
Buildings on an Irregular Shaped Site

THIS IS WHAT I HAVE: TYPICAL DDC SITE CONDITIONS

Numbers on the drawings reference numbers on the Site Conditions in the following chart.

#	SITE CONDITION	PARTICULARLY USEFUL STRATEGIES	REFER TO PAGES
1	Sidewalk	Tree pit enhancement; structural soil trenches, recycled content in concrete	29-33, 43-45, 114
2	Entry plaza	Rain gardens, trees for shade; recycled content in pavers; structural soil, planters	29-32, 87, 88, 91-92, 114, 117
3	Loading dock	Catch basin inserts, water quality inserts; recycled content in asphalt and base aggregates	86, 119, 122, 123
4	Parking and service area	Trees for shade, bark beds, infiltration areas, recycled content in asphalt, wheel stops, and base aggregates; pervious pavement	31, 83-84, 86, 89, 116, 119
5	Front yard	Rain gardens, vegetated buffer, shade trees, infiltration area, biofiltration techniques, recycled content in mulch/soil amendments, habitat enhancement, native plants	34, 40, 85-86, 89, 116, 119
6	Narrow side or rear yard	Infiltration swales, vegetated buffers; vine screens and planted walls, recycled content in fencing	34, 38, 90, 120
7	Land-locked, irregular, "left-over" area	Amended soils, turf alternatives, native plants; retain existing vegetation; biofiltration techniques	34, 36, 61, 62, 85-89
8	Steep terrain	Slope reduction bench, turf alternatives, habitat planting; minimize site disturbance, erosion and sediment control	40, 58-59, 93
9	Courtyard	High-albedo paving; infiltration areas; recycled content in pavers and furnishings; pervious pavement	83-84, 89, 109-110, 111
10	Shoreline edge	Minimize site disturbance; vegetated filter strip, native plants, habitat enhancement	40, 55, 85, 86
11	Wetland proximity	Minimize site disturbance; native plants, habitat enhancement; protect existing soils and vegetation, stormwater filtration techniques	40, 55, 60-63, 87-94
12	Campus condition	Amended soils, turf alternatives, native plants; retain existing vegetation; biofiltration techniques	34, 36, 61-62, 85, 86
V*	Previously paved	Recycled concrete aggregate or asphalt as base for new pavement or backfill	122, 123
V*	Shallow rock or impermeable soil	Underdrained bioretention, detention structures; reuse of rock or crushed rock aggregate in landscape and subbase	89-94, 123
V*	Elevation change at entry	Planters; recycled content in mulch and soil amendments	87, 88, 118, 121
V*	Perimeter enclosure	Vine screens, planted walls, windbreak/planted buffer	37, 38-39

V* = Various sites

SUSTAINABLE URBAN SITE PLANNING

What makes urban site planning “sustainable”? If basic site design already considers physical characteristics and functional goals, then sustainable planning extends the thinking to incorporate practices that are sensitive to the environment. A sustainable approach to urban site planning targets the following:

- Maintain and protect valuable stands of vegetation
- Minimize impacts of run-off to adjacent water bodies
- Reduce contribution to the urban heat island effect by using appropriate landscape materials, minimizing paved and impermeable surfaces, and reducing energy consumption
- Restore the health of degraded urban sites
- Reduce water consumption and protect water body quality
- Encourage access to public transportation and facilitate non-motorized commuting

Sustainable design also demands interdisciplinary design – a design process in which all professionals work together from the inception of the project. One of the traditional practices that limits environmental accomplishments is the separation of “landscape” design, and the landscape professional, from the initial site planning typically done by the architect. When the landscape architect is brought in later in the design process, many opportunities have already been lost.

Interdisciplinary design can maximize a project’s green potential if all consultants understand their roles and start together at the beginning of the project. The whole design team and affected stakeholders work together through all of the project phases and evaluate the design for cost, quality of life, future flexibility, efficiency, environmental impact and creativity. It is not useful to bring the landscape architect on board after the building is sited, just as it is not helpful to wait until major surface areas are identified before evaluating drainage alternatives with the consultants. Working together also means staying together for the duration of the project, including the construction and post-construction phases.

ZONING AND OPEN SPACE

Zoning is a powerful force in NYC development and construction; it regulates the density, bulk, height and minimum dimensions for yards and setbacks. These requirements help determine a building’s location, orientation and shape, especially influential on a tight site. If a proposed project is seeking LEED certification, then open space parameters, density, height, setback, yards, parking and permitted uses must be considered within the special context of LEED regulations.

In NYC, open space is a precious commodity, and the desire to keep it needs to be balanced with programmatic demands as well as the bulk and coverage permitted by zoning. Within the LEED rating system, creation and maintenance of open site areas, especially with native or adapted vegetation, is encouraged and rewarded. There is a LEED credit for “extra” open space, above that required by local zoning (NC Credit SS 5.2), as well as a credit for using native or adapted vegetation.

Zoning divides the City into three basic types of zoning districts: Residential (R), Commercial (C) and Manufacturing (M). The maximum size of a building on a lot in any district is determined by the maximum permitted floor area ratio (FAR). However, FAR does not determine where to put the footprint of the building. Each zoning district contains requirements or yards, building height and setback, and parking. The New York City Department of City Planning web site offers more detailed information regarding bulk and other zoning regulations.

<http://nyc.gov/html/dcp/html/subcats/zoning.shtml>

Many DDC projects are located within commercial and manufacturing zones. Generally speaking (there are exceptions; zoning must be analyzed for each site), sites in commercial or manufacturing zones may be built to full lot coverage at the ground level. Front and side yards are generally not



photo: Mathews Nielsen Landscape Architects

required in these districts; a 20 foot rear yard is required above the ground floor. In many cases, buildings do not use the entire potential “as of right” footprint space, but even at almost or full coverage there are sustainable landscape techniques that can improve the overall environmental performance, such as street trees, planters, vine screens, and planted roofs.

INTEGRATION WITH THE SITE PLANNING PROCESS

DDC provides its consultants with the Design Consultant Guide [<http://www.nyc.gov/html/ddc/html/desguide.htm>], which is a checklist of services and deliverables, as well as description of qualitative expectations for a project’s milestones. This *Sustainable Urban Site Design Manual* is intended to follow those established tasks and milestones, but not to alter or modify the contractual responsibilities described in the Design Consultant Guide. Outlined below are suggested tasks, linked to DDC’s phases of the design process, that will facilitate sustainable site design.

INVENTORY AND ANALYSIS PHASE

The Site Inventory Phase of a building design project investigates, quantifies, and documents the existing site characteristics and its context. The architect, landscape architect and engineers can analyze and use this data as the factual basis for land use and site design decisions. For a sustainable approach to site planning and design, we present these additional considerations:

The DDC Project Manager should start the site survey and subsoil investigation while waiting for project to be registered.

- **Testing.** Before beginning the design process, the consultant must request and obtain test results on the existing soil. By code, new building plans must include borings that quantify the site’s soils profiles. However this information does not provide information on many other aspects of the site’s underlying soil. Sustainable hydrologic and landscape planning also must be premised on tests that evaluate and document the chemical, biological and hydrologic characteristics of the site’s soils. These tests will aid in determining landscape/planting and stormwater management and design strategies as well as the budgets for these components. See “Soil Tests” in the Minimize Site Disturbance chapter for descriptions of suggested tests. Also refer to the USDA Soil Classification System [<http://soils.usda.gov/technical/classification/taxonomy>]. DDC has in-house groups that conduct subsurface investigations and provide topographic surveys at no additional cost to the project. The agency’s Project Managers are asked to request an up-to-date survey and geotechnical profiles immediately upon receipt of a project’s scope from a client agency. If these investigations haven’t started by the time a project consultant has been identified they should request them immediately. In this way, the studies can be done by DDC while the consultant’s contract is being finalized and registered;
- **Topography.** Understanding topography is essential not only for building placement, but also to plan for drainage and minimize earthwork and disruption to existing site vegetation;
- **Existing Vegetation:** Vegetation needs to be assessed for its quality and viability. Many sites contain invasive species and monocultural stands of trees. Other sites have mature trees and significant areas of healthy vegetation. Whatever the case, site vegetation needs to be identified and mapped. Sustainable site planning techniques mandate the retention of as much existing native vegetation as possible and the protection of these areas from construction impacts;
- **Microclimate.** In order to help determine the best opportunities for passive solar design and natural ventilation, diagrams of sun and wind patterns are important to generate before the final building location is determined. Remember that the “north-south” orientation of the Manhattan street grid is only a convenience, and the real orientation is shifted approximately 29° from true north toward the east;
- **Shorelines and Wetlands.** Development near aquatic areas must be based on an extensive understanding of sensitive resources and processes. Sites in close proximity to shorelines or wetlands are tightly controlled by federal, state and local regulations. Consult these before doing anything!

PRE-SCHEMATIC DESIGN PHASE

During DDC's Pre-Schematic Design Phase, the basic concept of the building is established, after exploring alternatives and setting design goals. For a sustainable approach, we present these additional considerations:

- **Sustainable Design Workshop:** When the results of the site inventory and analysis are available and the design program has been established, this meeting should be the first work session – and it must include all the consultants and the client group. Sharing site evaluation information will inform the team, and reveal sustainable design opportunities. Some typical site-related discussion items are below.
- **Use the Site Wisely:** Review and organize site activities such as public spaces, utility corridors and parking to reduce the building and paving footprints. Limit site disturbance to the minimum area necessary and coordinate with available infrastructure (utilities and streets). Define utility corridors early in the design process and coordinate these with any other program elements that will result in site disturbance.
- **Drainage Patterns:** In our highly urbanized environment it may not be immediately apparent that there is a natural drainage pattern, other than what can be seen flowing into the nearest storm drain. On every site there is room for improving the management of its stormwater, whether by creating vegetated areas to capture, detain and filter runoff, by using permeable pavement or green and blue roofs to slow runoff, or by using detention tanks.
- **Solar Orientation:** In NYC's climate, the shoulder seasons of early spring and late autumn are times when we most enjoy the sunshine. However, in warmer seasons, the site-related concerns are heat gain, re-radiation of heat into the atmosphere and the energy required to cool interiors heated by the sun. Optimizing the building's orientation and associated exterior public spaces can take maximum advantage of solar orientation to provide shade over such surfaces as parking and roads that contribute significant heat gain. Coordinate this site-related orientation analysis with the study of building orientation as it relates to daylighting and interior glare.
- **Wind and Climate:** Characteristics of the local microclimate need to be considered when locating new structures and exterior public spaces. This will maximize human comfort and reduce energy usage for heating and cooling. Prevailing winds should be used as natural "air conditioning." Assess the impacts of the new structure(s) on wind movement so as not to create channels that accelerate the wind (Venturi effect).
- **Vegetation:** Discussion of building location and footprint should consider the findings on vegetation – those areas to be protected, shade and micro-climate, relationship to neighboring open space (habitat linkage) and any areas of contamination to be mitigated.

DESIGN AND CONSTRUCTION DOCUMENT PHASES

The development of the site design and landscaping will vary greatly during the design development and document phases, depending on the nature and scope of the project. For a sustainable approach on all projects, we present these additional considerations:

- **Drawing Coordination:** The site survey and the project drawings should be set up using a common coordinate system before they are distributed as base plans to the consultants. The architect, civil engineer and landscape architect should collaborate on this – otherwise the project runs a high risk of encountering progress-delaying surprises. The architect should not distribute floor plans that are not referenced to the survey.



121 st Police Precinct, Staten Island, NY

- **Utilities:** Coordinate the placement of new utilities with areas of the site to be protected, e.g. trees, vegetation, natural topography. This should be done during the design development phase, when the engineers are beginning to lay out the utility lines across the site. Review the sewer capacity and drainage plan with DEP requirements to ensure that stormwater conveyed to the sewer system does not exceed the allowable flow and that the project will achieve required connections.
- **Site Access:** Vehicular access into a site is a critical decision that needs to be made at the outset, both to minimize paved areas and plan for drainage and plantings. Use the planned permanent road as the construction access route.
- **Vegetation:** Choose plants that are suited to the site conditions and can better survive in them. City agencies come to DDC for design and construction assistance, but they operate and maintain their own buildings, so match the plant palette to the maintenance capabilities of the users.



Marble Fairbanks Architects and Scope

Glen Oaks Branch Library, Queens, NY

- **Plan for Construction:** During Contract Document [CD] production, prepare a site protection and site demolition plan that specifies the protection of selected specimens or areas of site vegetation, street trees, environmentally sensitive areas, and areas susceptible to erosion. Require the contractor to develop and implement a plan for the recycling of construction waste. If the site is occupied by a structure or paving, specify the reuse, salvage or recycling of materials. Prepare an erosion and sediment control plan per the NY State Department of Environmental Conservation (NYS DEC) and the requirements of USGBC LEED™ system.

- **Materials for Landscaping and Construction:** Specify environmentally preferable products. The composition of materials used in site construction is a major factor in their life-cycle environmental impact. During the design development and construction document phases, research and specify products that maximize recycled content, materials harvested on a sustained yield basis and assemblies that can be easily deconstructed at the end of their useful lives. Give preference to locally produced products and other products with low embodied energy content. Eliminate the use of materials that pollute or are toxic during their manufacture, use or reuse. Consider trade-offs among life-cycle stages (i.e. raw materials acquisition, manufacturing, transportation, etc) when determining environmental preferability. Think about the big picture rather than simply shifting problems from one life-cycle stage to another.

CONSTRUCTION PHASE

The construction phase is a critical phase that requires vigilance on the part of the designer and the DDC project manager. For a sustainable approach, we present these considerations:

- Be vigilant in the enforcement of specified site protection techniques;
- Keep an eye out for field changes to utilities that may alter excavation paths that could adversely impact existing trees;
- Maintain good lines of communication with the construction manager and/or construction superintendent to protect existing and future planted areas from compaction and soil contamination from construction activities;
- Stay alert to the construction schedule to ensure soil tests are submitted and approved in a timely manner, that plant material is tagged and ready for installation during the correct planting seasons and that subsurface and adjacent construction is complete before installing plant material;
- Don't abandon the plants after the project is finished: work together with the client agency/end user of the site to be sure there are procedures in place to allow the plants to become well established, watered and replaced, if necessary, during the guarantee period.

HOW TO USE THIS MANUAL

This manual is intended for both project managers and design consultants who may not have extensive experience with site design and landscape architecture, as well as landscape architects who may not be wholly familiar with the unique conditions and challenges often encountered on NYC projects. The Overview, Chapter 1, outlines the key issues inherent in urban sites and specifically addresses techniques to mitigate the Urban Heat Island effect. This Chapter, Sustainable Sites for DDC, notes typical site design types and lists useful landscaping strategies that are commonly encountered by the City agency. Chapter 3, Maximize Vegetation, offers an overview on the benefits of vegetation in the urban environment and a variety of techniques to maximize vegetation. Chapter 4, Minimize Site Disturbance, discusses how minimizing site disturbance can save time, money and valuable resources. Chapter 5, Water Management on Urban Sites, explores issues and strategies related to stormwater management and water efficient landscapes. Finally, Chapter 6, Materials in Site & Landscape Design, focuses on strategies for incorporating recycled materials in site features and site construction.

Each chapter is organized in a similar manner, and contains diagrams, specifications, construction details, lists of resources, plant lists, etc. as appropriate to the chapter's content. Typical chapter organization is the following:

- Topic overview and benefits of a sustainable approach
- Laws, rules and regulations
- LEED™ relevance
- Key issues
- Techniques for implementation

This document is not meant to be a primer on site and landscape planning, but to highlight those approaches, specific techniques and materials that will make your project more green.



MAXIMIZE
VEGETATION

MAXIMIZE VEGETATION

Every DDC project offers the opportunity to plant trees and other vegetation and/or to protect those already on the property. Among many other benefits, planting trees and other vegetation in the urban landscape provides shade for cooling, cleans the air, and creates pleasant spaces. However, the urban setting is stressful for trees and plants. Pollution, restricted planting areas, poor and compacted soils, physical hazards, pests, limited sunlight/water and vandalism are some of the factors that can reduce the success rate of vegetation in New York City. The planting strategies contained in this chapter can help mitigate the stresses on vegetation and ensure their longevity and effectiveness.

Shade and Cooling: Shaded building surfaces may be 9 to 35° F cooler than the peak surface temperatures of unshaded surfaces. These cooler walls decrease the quantity of heat transmitted to buildings, potentially lowering air conditioning costs particularly during peaks of energy consumption.¹ Deciduous trees are particularly effective at modulating temperature as during the summer their foliage cools buildings by blocking solar radiation, while in the winter, after the leaves have fallen, the sun's energy passes through the trees and helps warm buildings. Another way trees and vegetation cool the air is through their roots

and evaporating it through leaf pores. Evapotranspiration is the process wherein plants convert air trapped in heated air into water vapor. Evapotranspiration alone can result in reductions to peak summer temperatures of 2 to 9° F, although not all plants evapotranspire at the same rate.

New York City is measurably hotter than the countryside because the buildings, streets and sidewalks absorb and retain the heat, a phenomenon known as the Urban Heat Island Effect (UHIE). Approximately 5 to 10 percent of the current electric demand in cities is spent to cool buildings, just to compensate for the heat island effect.² The City pays a steep price for this in terms of physical discomfort, increased energy demand and usage, and a variety of human health issues.



photo: Swanke Hayden Connell Architects

Office of Emergency Management, NY

Stormwater Runoff Mitigation: Reducing stormwater run-off is a necessity in New York City, where we have a combined storm/sewage system. New York's waterways are often polluted after heavy storms when the combined system is overwhelmed by the rainwater, and sewage is spilled into the rivers, carrying

with it chemicals and pollutants. Planted areas provide a natural system for the water to be intercepted and absorbed, mitigating the storm surge and keeping rain-swept debris from the sewer system. Trees reduce stormwater flow by intercepting rain water on leaves, branches and trunks, which then evaporates back into the atmosphere. Plant roots hold soil to prevent it from being washed away thereby reducing siltation. Deep rooted plants help improve a soil's porosity so that runoff can more easily infiltrate the ground. The NYC Department of Environmental Protection has found that wetland acquisition in the Staten Island Bluebelt area is cheaper than constructing a conventional storm sewer system.³ By slowing the overland flow, water is allowed to percolate into the ground, traveling horizontally below the ground before slowly seeping into wetlands, streams and aquifers. For more information refer to the chapter: Water Management on Urban Sites.



photo: Mathews Nielsen Landscape Architects

Bioswale – Potsdam Park

- 1 "What Can Be Done" Heat Island Effect U.S. EPA <www.epa.gov/heatisland/strategies/vegetation.html>
- 2 Brabec, E., 1992
- 3 "Conserving Land for People" <www.tpl.org>

Pollution Mitigation: Plants play an important role in reducing particulate and gaseous pollutants in the air, including carbon dioxide and sulfur dioxide, by absorbing them through their leaves and other plant parts. Particulate matter clings to branches, tree trunks, and leaves and is washed into the soil. Trees absorb other noxious fumes such as carbon monoxide and sulphur dioxide without tree damage.

The Neighborhood Tree Survey, a 2002 tree-by-tree study of three NYC neighborhoods, found that just three-hundred-twenty-two (322) street trees remove about 4.3 metric tons of carbon and 228 kg of other pollutants annually. This study, available on the Open Accessible Space Information System (OASIS), was conducted by several partner organizations: USDA Forest Service; SUNY School of Science and Forestry; Community Mapping Assistance Project; Environment of NYC; Trees New York and Environmental Systems Research Institute. For more information see www.oasisnyc.net. In 2007 the NYC Department of Parks and Recreation completed its street tree count; there are now 592,103 street trees, a 19% increase since the last 5-borough count in 1995. For a complete inventory and analysis of findings, go to the Parks website for the tree count summary.

TREES AND POLLUTION MITIGATION

One mature tree produces as much oxygen as is inhaled by a family of four in one year. An average tree stores 13 pounds of carbon; one acre of urban forest absorbs 6 tons of carbon dioxide and puts out 4 tons of oxygen; 17 trees absorb enough carbon dioxide annually to compensate for a car driving 26,000 miles.

Wind Mitigation: Tall buildings create pathways of high wind velocity (wind tunnels). Vegetated buffers disrupt those straight pathways. Windbreaks function by reducing air movement for 10 to 15 times the height of the windbreak, reducing the velocity by as much as 50%. Prevailing winter winds in the NYC area come from the north and northwest. The most effective windbreaks are planted in U or L shapes and extend about 50 feet beyond each corner of the area to be protected. Although a single row of low branching trees provides some benefit, several rows of trees underplanted with evergreen shrubs is the most effective, with the buffer remaining dense to the ground level.

Respite and Habitat: Planted areas are treasured green resources in dense, bustling urban areas like NYC, whether they are recreational parks, shaded trees along the street or a private garden view. Interaction with plants has been demonstrated to improve human psychological health and physical well-being. More planted areas, especially if they are linked or near others, attract and support birds, butterflies and wildlife.

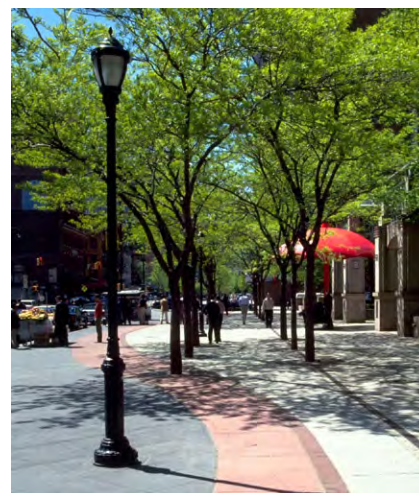

Greenwich Streetscape

photo: Mathews Nielsen Landscape Architects

Urban Planting For Positive Environmental Benefits: Trees and plants benefit the urban environment in several ways:

- Trees are effective in shading common urban paved surfaces, particularly parking lots, plazas, sidewalks, and roads, which if left unshaded, contribute to the Urban Heat Island Effect. Refer to Technique: Structural soils, tree trenches.
- Plantings can cool buildings by using shade trees or vertical vine screens on the southeast or southwest exposures. Refer to Technique: Vine screens and trees for shade.
- Vegetation contributes biomass (leaves, branches and other plant components in layered planting that help clean air pollutants from the atmosphere. Refer to Technique: Biomass
- Ground covers should replace lawns to reduce pesticide, fertilizer and fungicide use that pollute soil and water, using disproportionate amounts of potable water. Refer to Technique: Lawn alternatives.
- Plantings can slow wind velocity, potentially lowering heating costs. Refer to Technique: Windbreak.
- Plantings reduce runoff and the frequency of combined sewer overflows, and help cleanse stormwater. Refer to the chapter: Water Management on Urban Sites for strategies to introduce bioswales, rain gardens and other techniques that detain and filter urban runoff.
- Plantings create habitat for birds and beneficial insects. Refer to Technique: Plants for Habitat.
- Plantings promote human comfort, offering shaded areas, buffering from noise and traffic, stimulation of the senses and positive psychological benefits.

LAWS, RULES AND REGULATIONS

The design team should be aware of the many regulations that cover the selection, planting and removal of trees and other vegetation. City and State agencies promulgate these regulations for a variety of reasons – to promote ecological diversity, encourage species survival and protect other vegetation from pests.

SUMMARY – LAWS, RULES AND REGULATIONS

See web links below for more information. This is a summary of key regulations, not necessarily all that may apply.

AGENCY	LAW, RULES, AND REGULATIONS 2008	APPLICABILITY
NYC Department of Parks & Recreation	Restitution or replacement required if trees are removed; Street tree planting permit; Tree species, tree pit sizes, soil types and locations within sidewalks; NYC DPR Tree Planting Standards	Street trees; trees on NYC Parkland
	Quarantine zones for Asian Long Horned Beetle limit tree species allowed	Identified zones in Queens Brooklyn, Manhattan – DPR or DOT land only
NYC Department of Design & Construction	Tree restitution pending; Quarantine zones in all boroughs of DDC managed projects	Trees damaged in construction; All projects managed by DDC
NYC Department of City Planning	Special Natural Area Districts require special protections	Areas and requirements identified in NYC zoning resolution
	ZR Article II, Chapter 5 and Article IV, Chapter 4: Accessory Off-Street Parking and Loading Regulations	Perimeter and interior landscaping for commercial and community facility off-street parking lots
	ZR Article II, Chapter 3: Street Tree Planting in Commercial Districts	Quantity of street trees required based on frontage
	ZR Article II, Chapter 6: Special Urban Design Guidelines -- Streetscape	Developments in R9 and R10 Districts with private road and street tree planting
NYS Department of Environmental Conservation	Reporting Law; Annual Report for Restricted Pesticides	Use of pesticides on plant material during (& after) construction
NYS Department of Transportation	Native plants required for 85% of plant species	Projects that utilize Federal funding on DOT land
NYS Department of Agriculture and Markets	Established quarantine zones for ALB in Brooklyn and Queens effective March 2002	Quarantine areas; extent of quarantine zones in constant flux. Refer NYCDPR web site for updated information
NYC Department of Transportation	Sidewalk clearances require approval	Street trees

Web links – Note that full regulations not always available on-line.

NYC Department of Parks & Recreation

http://www.nycgovparks.org/sub_your_park/trees_greenstreets/beetle_alert/beetle_alert.html

http://www.nycgovparks.org/sub_permits_and_applications/images_and_pdfs/street_tree_planting_permit_guidelines.pdf

NYC Department of Design & Construction

NYC City Planning <http://www.nyc.gov/html/dcp/pdf/zone/art10co5.pdf>

NYC Department of Environmental Conservation

NYS Department of Transportation http://dot.state.ny.us/tech_serv/mat/manuals/murk2amim.pdf

LEED AND VEGETATION

With the enactment of Local Law 86 of 2005, the City now requires most of its projects to meet the Silver level of the LEED certification process of the U.S. Green Building Council (USGBC), as well as specific energy and water efficiency requirements. Maximizing vegetation contributes to credits in Sustainable Sites, specifically for protecting and restoring habitat, and for helping to mitigate the heat island effect with the shading qualities of plants. Water Efficiency credits may be achieved by reducing or eliminating the use of potable water in irrigation, with a high efficiency irrigation system, no irrigation or the use of on-site rain water or waste water.

KEY ISSUES OF PLANTING IN NYC

SELECTING PLANT SPECIES

To achieve the many vegetation benefits, the designer needs to understand several key issues that affect plant selection.

Microclimate: Microclimate is the suite of climatic conditions measured in localized areas near the surface. These environmental variables, which include temperature, light, wind speed, slope and moisture, provide meaningful indicators for plant selection and sustainable ecological communities. The built environment plays a major role in determining a site's microclimate. Existing and proposed structures can have negative impacts by casting dense shade, accelerating wind velocities, and raising ambient temperatures due to heat gain. Conversely, the built environment can provide positive impacts by contributing reflected sunlight or decreasing wind velocities.

In planning for plant selection, the designer needs to conduct a pre and post-site analysis of these factors to ensure that plants are properly located to mitigate or take advantage of microclimatic conditions.

Size Matters: Plants living in close proximity make demands on the same resources, in some instances causing destructive competition, and in others creating beneficial interactions. Plant roots compete for nutrients and moisture while foliage competes for sunlight. Understanding a plant's mature natural structure (root spread and canopy height and habit) will help determine the amount of space it requires to develop into a healthy specimen.

Plant selection is typically done by starting at “the top” – locate canopy trees first, draw their mature height and branching spread, then draw a section to evaluate the vertical relationships. If it is a high branching tree, then smaller, understory trees or shrubs tolerant of dappled shade can be planted within its canopy. Lower branching trees or shrubs may allow shade tolerant herbaceous plants to be located within their spread, and so on. This is called biotope-based planting arrangement along the light-shade continuum and mimics the distribution of plants found in natural environments. For example, in south or west-facing conditions, taller plants can provide needed shelter for shade-loving ground covers.

LEED CREDITS

Maximizing vegetation can contribute to the following LEED credits:

Sustainable Sites:

Credit SS 5.1 Site Development

Protect or Restore Habitat

Credit SS 5.2 Site Development

Maximize Open Space

Credit SS 7.1 Heat Island Effect

Non-roof

Credit SS 7.2 Heat Island Effect – Roof

Water Efficiency:

Credit WE 1.1, 1.2 Water Efficient Landscaping

Reduce by 50% or 100%

Credit WE 2 Innovative Wastewater

Technologies

Available planting space is most critical for canopy trees. Tree branches can cause damage to building facades, and tree roots can heave pavements or compromise utilities. Falling branches and leaves damage roofs and clog gutters, so proper spacing between adjacent structures and trees is the first priority. The second priority is the spacing between large trees; to allow a tree to develop its natural form, it should not be crowded by another tree of equal height and spread.

For smaller plants, it is also important to know their mature height and spread, because in general, the foliage mass is comparable to the root spread. This information can be used as a guide to spacing smaller plants without creating destructive competition. Placing smaller plants in the vicinity of canopy trees is more difficult to assess as major tree roots far exceed their canopies and they are more effective at extracting nutrients and moisture than the shallow roots of smaller plants.



photo: Mathews Nielsen Landscape Architects

Biotope planting arrangement

Functional Considerations: Trees and plants can be used to solve site-specific problems, such as light pollution or glare, local noise issues, or wind tunnels. Based on the site analysis and building location, plant selection should be tailored to solving or improving site conditions. For example, placing shade trees or vine screens on west facing exposures can reduce cooling loads. Steep slopes can be stabilized using aggressive, fibrous rooting shrubs or ground covers. Judiciously placed evergreens can be located around parking lots to protect lower floor occupants from the glare of headlights. Trees in particular are very effective at shading pavements, thereby reducing the urban heat island in addition to contributing biomass that serves to reduce air pollution.

Human Comfort: Many of the functional capabilities of plants also result in benefits to people. Plant selection should strive to include plants that have noticeable characteristics in all four seasons. Spring is the opportunity to introduce perennial bulbs, flowering trees; summer lends itself to strong colors and fragrance-emitting flowers; fall suggests use of herbaceous plants with persistent seed heads or trees that turn dramatic colors, and winter is a time to appreciate bark textures and evergreens.

Plant Choices: There are tens of thousands of plants to choose from that are adapted to the New York climate (Zone 6A or B as classified by the USDA based on minimum recorded temperature). In recent years, there has been growing interest in using native or naturalized species. Native species are defined as those naturally occurring in a defined area prior to European settlement. Naturalized species are those that are not native but reproduce and maintain themselves without human intervention. Exotic plants are not naturally occurring, presently or historically, in any ecosystem in the United States. All these may be attractive and have the habitat-enhancing characteristics that attract birds and insects. However, native species in general are better adapted to local climate, soils, rainfall patterns and thus require less supplemental water, fertilizer, and are more resistant to pests and disease. Use of primarily native species results in lower maintenance costs, water usage, harmful chemicals that can pollute water sources, and is a more sustainable strategy for connecting habitat patches.

ASIAN LONGHORNED BEETLE AND OTHER PESTS

The Asian Longhorned Beetle (ALB) is a species of Anoplophora, a cerambycid beetle. It was introduced to this country around 1990 from China, probably within solid wood packing material, and was first discovered in New York City in 1996. They have been intercepted in ports and warehouse sites throughout the US. ALB range from $\frac{3}{4}$ " to 1-1/2" inches in size with antennae in length from 1 to 2.5 times their body length. Both sexes have up to 20 irregularly distinct white spots.

The beetle has a 1 year life cycle, which it completes within particular hardwood species. It is destructive to the tree during all phases of its life cycle but the greatest damage occurs during the fall and winter larval stage when the beetle tunnels through the tree, including the heartwood. An infestation of Asian Longhorned Beetle is 100% fatal to the tree it infests. However, the beetle infests only certain hardwood species, called host species, and consistently ignores non-host species trees. Typical host species include all maples, ash, elms, London plane tree, hackberry, horse chestnut, poplars, alder, birches, mountain ash, willows and box elder. Unfortunately, the list of hosts is not static, and species are occasionally added and removed. See below for references.

Avoidance is the primary strategy for controlling this destructive pest and preventing its spread to other trees, because there is no effective treatment at this time. ALB flies or spreads through the transport of host material to new sites.

An affected tree can be detected in several ways -- the web site of the NYC Department of Parks and Recreation describes them with photos. Once detected, an infested tree must be immediately cut, chipped and incinerated. If an infested tree is suspected on a property, call the USDA APHIS hotline at 1-877-STOP-ALB. An ALB inspection should become part of an initial site survey for DDC projects.

Quarantine Zones in New York City have been established by the U.S. Department of Agriculture's Plant Health Inspection Service to slow the spread of the pests. No one may plant host species within the quarantine zones. In May 2007, NYC DPR established quarantine areas in much of Brooklyn, Queens, and Manhattan. The Bronx and Staten Island are currently outside the quarantine area, although a planned area has been designated on Staten Island. **NYC's Department of Design and Construction considers locations of all its managed projects as quarantine zones.**

Quarantine zones and the restrictions on planting host species is a much-debated topic. While USDA APHIS regulations do not prohibit the planting of host species, NYC Department of Parks and Recreation discourages the planting of host species to minimize future tree loss. The goal of the quarantine zones is to limit transport of ALB and host material, and manage disposal. While the ALB quarantine zones are designed to be of sufficient size to limit adjacent plantings, the quarantine zones are only as effective as the public's understanding of these zones.

Plant diversity is an important strategy that the designer can employ to help prevent the spread of the ALB and other plant pests, because the beetle chooses host species and avoids non host species. Non-host species include: Arborvitae, Baldcypress, Linden, Oak, Catalpa, Dawn redwood, Hornbeam, Ginkgo, Juniper, Kentucky coffee tree, Tulip Poplar, Serviceberry, Honeylocust, Turkish filbert and Sweetgum. Recent pest breakouts in other states are compelling demonstrations of the importance of planting a variety of species. In 2001, the Citrus Longhorned Beetle (*Anoplophora chinensis*) was discovered in Washington State and Emerald Ash Borer was discovered in both Michigan and Ontario in 2002, resulting in tree removals in the millions. Because we tend to plant trees of similar species along streets and in our public spaces, when the pests hit, all of the species are often affected, resulting in barren streets and gaping holes. Planting a diversity of species ensures that some vegetation will remain when an endemic, like a major pest infestation, occurs in the future.



Links to ALB references: General Information about the beetle and short list of affected species.

<http://www.na.fs.fed.us/spfo/alb>

<http://ceris.purdue.edu/napis/pests/alb>

<http://invasivespecies.gov/profiles/asianlongbtl.shtml>

<http://uvm.edu/albeetle>

PLANNING FOR MAINTENANCE

DDC's client agencies are responsible for the maintenance of their buildings and grounds, and their experience and capabilities vary by agency. Success of the landscape design will depend on the team's understanding of the client agency, and crafting a plan tailored to their capabilities and tolerance for landscape maintenance. For example, a new fire or police station will likely receive only minimal grounds maintenance while a project on Parks Department property can expect a high level of landscape maintenance.



photo: Mathews Nielsen Landscape Architects

Diversity in Street Tree Species

All DDC projects require a High Performance, or LEED, workshop during the design process. A portion of this session should be devoted to landscape issues, with a full review of the client agency's maintenance procedures, and discussion of future options. Although there are sustainable landscape techniques that require minimal maintenance, others that may be appropriate for the project should be discussed with their maintenance requirements, e.g. biofiltration swales that require periodic sediment removal, porous pavements that require annual flushing, or plantings that need supplemental watering during plant establishment and drought periods.

Landscape partnerships are a possibility – agreements with another City agency or not-for-profit group to assist in the upkeep of the plantings. A few projects in New York City are models for public-private collaboration. For example, the Horticultural Society of New York created a program called Green Branches, under which the Society designs and finances public library gardens. The program started by emphasizing Carnegie branch libraries in the five boroughs. Maintenance on many of these new gardens is being done by local volunteers. Similarly, Police and Fire Departments are often located within residential neighborhoods in close proximity to schools, and a meaningful collaboration could be created between them. This could be an opportunity for urban school children to be involved with maintaining and watching a garden grow.

NATIVE PLANT SPECIES

There are 1,359 native species in New York City according to NYC DPR Natural Resources Group

Project specifications should require guarantees for the plant material and a maintenance contract from the landscape contractor. Currently, DDC provides for a two-year guarantee on plant material purchased for public building grounds, as is required under contracts administered by the Department of Parks and Recreation.

In order to ensure that a landscape has optimal chances for survival, the designer needs to be mindful of a number of factors including good soil preparation, protecting future vegetated areas from construction damage, positive drainage (surface flow or underdrain system), appropriate plant selection and spacing, and relationships to people and vehicles. These issues can be resolved through tightly written specifications and careful planting design.

Urban hazards add to the maintenance burden – e.g. bicycles, parking cars, de-icing compounds, vandalism. The design team can help mitigate this potential incidental damage by anticipating it in the design process.

Suggestions include:

- Locate bike racks in high visibility locations from adjacent roads and sidewalks to discourage locking bikes to streets trees. Although these bike racks serve the users of the building, it is important to include more bike racks for the general public as well.
- Protect planted areas from dogs, rolling dumpsters etc. by surrounding them with practical and attractive barriers, such as low metal wickets.
- Recognize that sodium chloride, used as a de-icing salt, damages plants and contaminates soil. Physical measures that minimize salt contact by diverting runoff away from planted areas is one strategy. Avoiding the need for deicing by heating the sidewalks in sensitive ecological areas may be appropriate. Note that other products, such as calcium magnesium acetate (CMA) or sand/grit, are safer for the landscape, and NYC is reviewing its purchasing policies.



photo: Mathews Nielsen Landscape Architects

Bike racks can prevent damage to trees

DDC's policy is that no potable water may be used for permanent irrigation of plant material. Current DDC specifications require that new plantings be provided with supplemental watering in the event of inadequate natural rainfall during the two-year warranty. However, this time frame is not sufficient to assure that plant roots develop adequately to compensate for periods of low rainfall. A newly planted 3 inch caliper tree will take three years before its root system becomes sufficiently established to extract water efficiently from its surrounding soil (assuming good soil structure). Smaller woody shrubs and herbaceous ground covers have shallower root systems and cannot compete with trees for water. New York City has had 4 severe-to-extreme droughts within the last 20 years that represent sustained dry periods in which supplemental watering was required to ensure plant survival even for more mature plantings.

Supplemental Water: There are several strategies to provide supplemental water without installing wasteful irrigation systems that use potable water:

- Design planted areas based on soil moisture and microclimate creating “water use zones”. Select plants based on high, moderate and low water usage. Supplemental water, using drip or hand watering, should only be necessary in high use zones after the plants have become established or in moderate zones in the instance of sustained drought.
- Replace turf areas (high water use) with alternative ground covers, meadow or herbaceous plants. Refer to Technique: Turf Alternatives.
- Improve the structure of poor soils using amendments. Preventing soil compaction during construction and amending native soil will allow for optimum root penetration for plants to become resilient to drought.
- Install a drip irrigation system using captured rainwater or filtered grey water. To avoid problems of bacterial growth or build-up of harmful salts and alkalinity, use a reverse osmosis water purification system.
- Use a “gator bag,” a polyethylene tree watering bag that is wrapped and zipped up around a tree trunk and releases water slowly over a 10 hour period. Trees of 1 to 4 inch caliper will require a 20 gallon capacity bag, refilled once a week for the duration of their establishment period or a drought.
- Use portable “leaky hoses,” ordinary garden hoses with frequently spaced pinholes. Connect the hose to an exterior hose bib and allow to run until one inch of water has been applied to the soil. Repeat weekly throughout the plant establishment period or drought.
- To reduce moisture evaporation, use mulch such as pine straw or shredded hardwood that allow water, nutrients and oxygen to freely penetrate to plant roots. Typical applications are a 2 to 3 inch layer. Do not mound mulch against tree trunks to avoid wood rotting diseases.



photo: Mathews Nielsen Landscape Architects

Gator bags provide supplemental water to new trees

REMOVING AND REPLACING TREES

Trees on public property, whether along the street or within the project's lot, are valuable urban resources, and DDC encourages the design team to save or replace all mature site trees as part of the project's design strategy. In addition, preservation, transplantation or replacement is required for all street trees, and any trees on NYC Department of Parks and Recreation property. There are specific regulations within the NYCDPR specifications for tree protection and replacement. A replacement formula calculates the size and number of trees required to replace the lost tree, based on its size – called Basal Area Replacement Formula (BARF). When saving or transplanting is not feasible, the project must apply to the Department of Parks and Recreation for approval, and pay a tree-replacement fee. (On Parks property, removing, damaging or killing a tree intentionally or accidentally is a civil and/or criminal offense and punishable under NYC Administrative Code 18-129, effective August 2006.) If a tree is too large to successfully transplant (typically 6-9 inches in trunk diameter), then multiple smaller trees may replace the larger tree, as long as the combined calipers of the smaller trees equal or exceed that of the original tree. Trees that cannot be retained in place may be transplanted on the property, or nearby property within ¼ mile of the original tree's location. It is important that removed trees are relocated / replaced within close proximity to the original tree location to ensure that the trees continue to contribute to the quality of the local community's environment.

The New York City Department of Parks and Recreation also requires “a two (2) year guarantee on trees commencing after the final acceptance and the completion of the whole work of the contract.”⁴ This ensures that newly planted trees are protected, and the contractor is charged with replacing any dead or destroyed trees during this period. “Trees that die within the two (2) year guarantee period shall be replaced as many times as necessary so that there is a live tree at each location at the end of the guarantee period...the cost of replacement(s) shall be included in the unit price bid for the various furnished items of the contract.”⁵

TREES AND COOLING

A mature tree with a 30 foot crown transpires approximately 40 gallons of water per day. One mature tree is equivalent to 3 tons of cooling.

EFFECTS OF GLOBAL WARMING ON PLANTS

Though it will take decades to obtain accurate scientific data of the effects of global warming on plants, some evidence is clear. While plants have adapted to millennia of change, the concern is that genetic adaptation cannot keep pace with the sudden shift in climatic circumstances. The average global temperature is 0.72 to 1.44° F warmer than a century ago. Global sea levels have risen between four and eight inches in the last century. In addition, during the past twenty years, the northeast has seen the most sustained droughts and heaviest rainfalls since NOAA began weather records. What does this mean for urban planting strategies?

- More vegetation needs to be planted. Greenhouse gases, especially carbon dioxide, are the pollutants largely responsible for global warming. Plants take up carbon dioxide through photosynthesis, thereby reducing it in the atmosphere. Trees and large shrubs contain substantial biomass (leaf area), which is capable of absorbing a variety of air pollutants. Trees trap infrared radiation that causes lower atmospheric layers to warm to a higher temperature than would otherwise be the case.
- Tree planting is therefore very beneficial to mitigating the urban heat island effect.
- Rising water levels, heavier rainfall runoff, and sustained droughts will have an impact on plant species adjacent to shorelines and within wetlands. Moisture-loving plants (hydrophytes) are adapted to specific durations of inundation. However, changes to water levels and their relative duration will make plant selection extremely difficult.
- There are new considerations when selecting plants for sequential spring bloom. While most plants flower in response to relative length of daylight (photoperiod), some spring flowering woody species and perennial herbs also respond to accumulated heat.

4 NYC DPR Tree Planting Guidelines, 2008

5 *ibid*

- Plant diversity is more important than ever. Changes in temperature may affect the range and density of plant pests through migration and egg laying. Though there is scant research on the effects of global warming and specific plant pests, there is substantial evidence that many animal species are undergoing shifts in habitat. Plant selection should strive for maximum diversity to avoid devastation from pest infestation.
- Global warming is causing some native plant species to migrate northward. While the urban ecosystem is hardly a wilderness, care should be exercised when selecting native plants that are particularly adapted to cold temperatures. Species that require cold or diurnal temperature variation to produce sugar will be especially affected by later sustained freezing night temperatures, which trigger the onset of brilliant fall foliage. Plants respond to both day length (photoperiodism) and temperature to kick into dormancy.
- Increased temperatures affect soil temperature and germination rates for seeds and bulbs. Specifications should be reviewed for appropriate seasonal limitations regarding seeding of grasses and other herbaceous plants as well as bulb planting.
- It is not appropriate to just shift the selected plant list southward. We are still getting winter temperatures that hit our record lows (that determines the climatological zone), so while temperature increase is affecting bloom time, birds nesting, fall color, etc, it is not changing the fact that we get days of very cold temperature.



photo: Mathews Nielsen Landscape Architects

Street flooding due to storm in San Francisco

REFERENCES

- “USEPA Global Warming Impacts.” www.epa.gov
 “Consequences of Global Warming”. www.nrdc.org
 “Historic Weather Records.” www.nws.noaa.gov

PLANYC 2030 INITIATIVE

Plant 1,000,000 trees by 2017

TECHNIQUES FOR MAXIMIZING PLANT BENEFITS

SUMMARY – KEY TECHNIQUES

See text for more detail.

VEGETATION TECHNIQUES	APPROPRIATE APPLICATIONS	RESOURCES
Structural Soils in trenches	Parking lots, sidewalks / streets, plazas and other paved areas	detail
Continuous Soil Zones	Narrow or confined spaces	detail
Amended Soils	All applications	–
Maximizing biomass	All applications	detail
Turf Alternatives	Planting strips, and un-occupied areas	–
Windbreaks	Northern site exposures	detail
Vine Screens	Narrow spaces to shade southern exposures	detail
Habitat Enhancement	All applications	–

STRUCTURAL SOILS IN TRENCHES

Getting trees to grow in New York City is a challenge. A typical NYC tree pit is 5 feet by 5 feet, although NYC DPR allows pits as large as 5 feet by 10 feet if space permits. Two of the most significant obstacles that large trees face in the crowded urban environment are soil volume and compaction caused by the weight of constant traffic and pavement, leading to poor soil aeration and drainage. Under these conditions, trees simply stop growing and become more susceptible to drought and weak roots. For all trees, more soil volume and better quality soil is the key to health and plan longevity. When load-bearing is required, the technique of using structural soils encourages trees to grow while at the same time providing a base material for pavements.

Structural soils are designed to accomplish two objectives: 1. To provide the load bearing capacity required for base courses of pavement, and 2. To offer adequate soil volume for urban trees to grow to full size and maturity. The term structural soil refers to a mixture of sand, gravel and soil which serves as the tree’s growing medium. The physical composition of structural soil forms a “lattice” of load-bearing stones that provide stability while creating interconnected voids for root penetration, air and water movement.⁶ The diagram in this section illustrates how the stone can leave adequate interstitial space for soil particles, air, and water while providing the compaction necessary to support pavement.

TREE PITS

A typical NYC tree pit has a 100 CF soil volume; a mature tree requires between 300-700 CF of soil. (Urban, J.) The roots of a 4 inch caliper tree will outgrow a typical tree pit in 4 years. (Doherty, K. 2003)

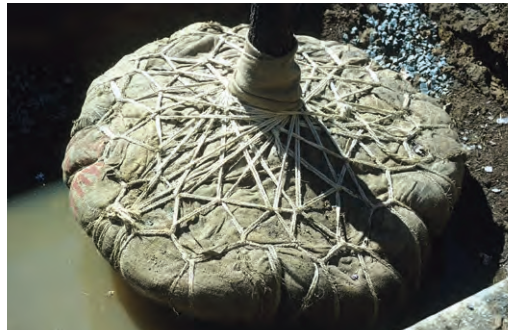

New tree installed in tree pit. Structural soil backfill facilitates air and water movement

photo: Mathews Nielsen Landscape Architects

6 Bassuk, N, Grabosky, J & Trowbridge, P, 2005, pg.2-3

Structural soils are most useful for trees planted in paved areas, such as parking lots, sidewalks, plazas, and other paved surfaces. They mitigate compaction and allow the tree pits to be enlarged, with the following benefits:

- Soil provides macro-pores needed for drainage and root penetration.
- Life expectancy and maturity of trees is 4 to 5 times greater when adequate soil volume is provided for roots.
- Pavement uplift is reduced by encouraging deep root penetration, and the structural soil protects against frost heave.
- Structural character withstands compaction cause by foot traffic, vehicle loads, and vibration, and can serve as a base for many kinds of pavement.
- Structural soils are suitable both as pavement base and root medium, simplifying the soil profile and thus the design and construction process.
- Because structural soils can be compacted to 95% standard Proctor density, they provide adequate bearing strength for light pole foundations and other street appurtenances.

However, there are some limitations that designers need to consider for the design and specification of structural soils. The considerations include the following:

- Uniform blending of structural soil components requires either special equipment (pug mill) or careful monitoring (volume mixing with front-end loader).
- Pre-mixed structural soil cannot remain stockpiled for long periods of time, nor be transported over long distances due to separation of component parts.
- Structural soils are relatively recent and there is much debate as to the base materials and their correct proportions in the final mix. Testing of individual components as well as testing of the final mix prior to installation is essential.
- Fully tested structural soils are proprietary (specific to an individual manufacturer) and may be difficult to implement in public work.
- Plant selection for structural soils should avoid ericaceous species (species that require acid soil). There isn't enough humus/peat in this mix to satisfy plants which require a low pH (5.5 or less).
- House connections (gas, water and sewer) may require special pipe bedding, thereby interrupting trench continuity.

There are a variety of specific structural soil types, with variations of the mixture of sand, gravel, and organic material. These variations are due to differences in freeze-thaw cycles, the availability of local gravel types, sub-grade temperatures, vegetation types, etc. However, for all variations, a carefully chosen balance between stone aggregate and soil is necessary, to meet certain performance characteristics as both a growing medium and structural base. Using too much stone may result in not enough soil medium for nutrients or open pores for root penetration. Using too much soil may result in insufficient structural medium for the pavement. Soil scientists do not always agree, but the "industry" now accepts "CU-Soil" as the baseline. However, some authorities have their own specification, and requirements should be reviewed for each project.

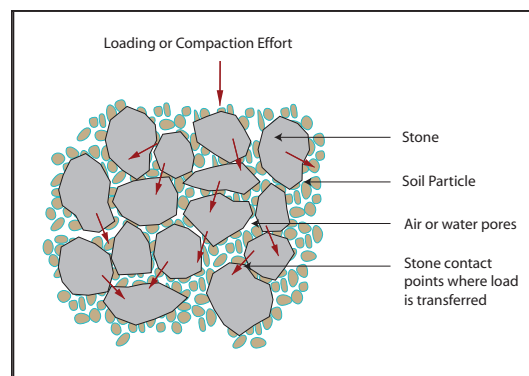

Structural soil composition

APPLICATIONS OF STRUCTURAL SOILS

Structural soils allow the integration of trees and vegetation with paved areas, most commonly in combination with street trees because of their close proximity to both sidewalks and roadways. While structural soils can support impervious poured-in-place concrete, optimal water penetration is achieved by using permeable pavers, such as cobbles, around the tree. A sub-drain connecting to the existing stormwater system is recommended. The diagrams in this section show several examples of how structural soils can be used to plant trees and other vegetation where pavements are also necessary.

New Street Trees Application: Structural soil works much like conventional soil. The diagrams here show how structural soil can be installed underneath concrete sidewalks and continue into the root zone of the proposed street tree. Typically, structural soil is installed as base material throughout the construction area, then concrete is poured for the sidewalk with an adequate opening left for the trunk of the tree and proper water absorption into the soil. Then the tree can be planted right into the structural soil with regular planting soil used as backfill around the root ball. Within a site, this same strategy applies to trees in plazas.

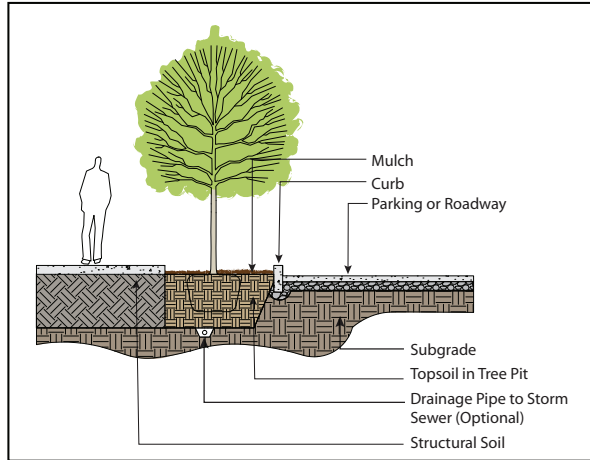

Structural soil under adjacent pavement provides additional soil volume for tree roots

Similarly, permeable pavers can be used to pave the areas directly adjacent to the tree trunk. Pavers are set in a small setting bed material, such as sand on top of filter fabric, all resting directly on structural soil. Permeable pavers around the tree, in combination with the structural soil, make for optimal planting conditions because of the increased ability for water to enter the soil.

Parking Lot Application: Structural soil can be utilized under the adjacent pavement on parking lot islands to allow tree roots to grow outward from under the planting bed. Structural soil will encourage roots to grow downwards and away from pavement, preventing cracking. Irrigation may be necessary for the first few years of the tree's life to account for the reduced amount of water entering the soil under the surrounding asphalt.

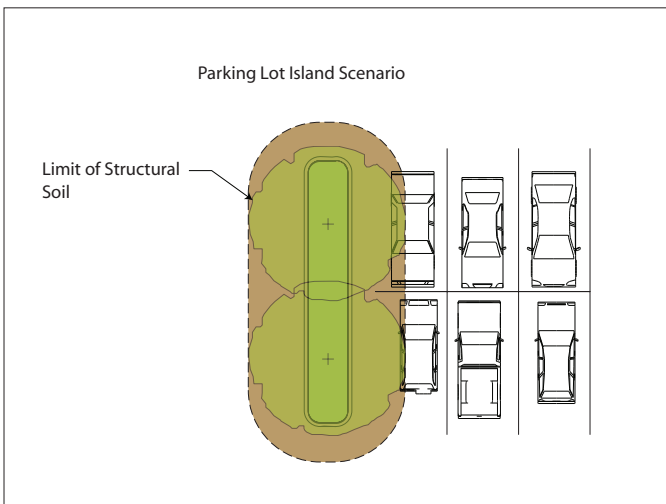

Structural soil use for parking islands. Enlarged and shared soil zone allows for better tree development

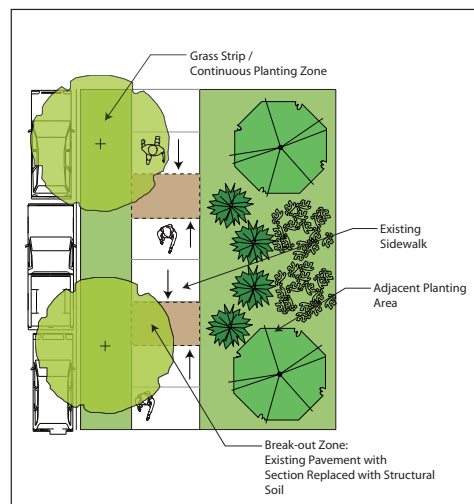

Connect trees with limited soil volume to adjacent planting areas using break out zones

Retrofitting Application - Pavement near Existing Street Trees with Break-Out Zones: When replacing pavement areas adjacent to existing trees, the application of smaller amounts of structural soil under the replaced pavement can bridge a gap between the tree planter and an existing non-paved area. These areas, called Break-Out Zones, lead a tree's roots through the barrier of compacted soil into a nearby pervious area that is not paved and not compacted. Tree roots quickly take to break-out zones and begin to stretch out into the new found root space. This method is also useful for conserving the quantity of structural soil used. Special attention should be paid to whose property the roots are being led to.

TECHNICAL STRATEGIES AND DETAILS FOR STRUCTURAL SOIL

During Design

- Design structural soils to provide a load-bearing aggregate lattice to support a pavement. The lattice provides stability through stone-to-stone contact while providing interconnected voids for root penetration, air and water movement. Gap-graded angular stone is recommended over well-graded stone particles to ensure porosity in the matrix. NYS or NYC DOT aggregate soundness and durability requirements apply to the stone particles.
- Design structural soils to provide nutritional components including a loam with a higher than normal clay and silt content. Consider addition of organic matter. The objective is to coat the stones with soil and allow the nutritional material to reside within the stone matrix. Consider use of a soil tackifier to facilitate uniform mixing, transportation and dumping.
- Specify compaction to 95%-100% Standard Proctor density. Testing should follow ASTM D698-91 method D protocol or AASHTO T-99.
- Install and compact in 6 inch lifts.
- Design pavement and planting sections simultaneously to maximize soil volume for planting.
- Provide for positive drainage between subsoil and structural soil to prevent water-logging.
- Do not install pavers over the root ball. This will result in the tree being planted too deeply to accommodate the paver and setting bed thickness. Install pavers (granite block or other unit paver) within the remainder of the pit or trench. Mortar only the inner course (closest to the tree) to prevent theft and shifting of pavers; the remaining open joints will allow water and oxygen to reach tree roots.

During Construction specify that the contractor do the following:

- Test components at the source prior to shipment to the job site.
- Perform on-site mixing of structural soils. Test mix prior to installation.
- Install and compact in 6 inch lifts.

Structural soil installation details that you may use are at the end of this chapter. Structural soil sample specifications are available on the sustainable design website of DDC and are also available in NYC DPR *Street Tree Planting Standards*.



Soil Telebelt enables soil installation in elevated or inaccessible places and prevents compaction from truck tires

photo: Matthews Nielsen, Landscape Architects

CONTINUOUS SOIL ZONES

Continuous soil zones are essentially large tree pits or trenches that give each tree access to more or better soil. The continuous soil zones can be filled with either topsoil or structural soils depending on the nature of the area between trees, project budget and other site constraints. The increase in soil volume allows plant roots better access to air, moisture and nutrients. And the larger the planting zone, the higher the survival rate of the plant. This is an expanded version of the typical planting technique of tree pits.

Trenches and continuous soil zones support the growth and lifespan of vegetation because of the following:

- The larger planting zone enables greater absorption of stormwater runoff, and reduces the need for drainage and watering systems. This can offset the need and costs of soil trenching necessary for installing utility pipes and systems. Soil trenching is not only expensive, but can be harmful by interfering with the root systems of trees.
- Encourages larger, healthy trees by providing a greater area for root growth, and shares resources among individual trees.
- Minimizes the risk of heaving pavements and the associated costs of repair and tripping injuries.



photo: Mathewus Nielsen Landscape Architects

Continuous planted soil trench benefits trees and reduce pavement upheaval

Continuous soil zones are recommended whenever the space is available and their construction does not endanger adjacent existing trees. They are not automatically used because there is some added construction cost for additional excavation and backfill.

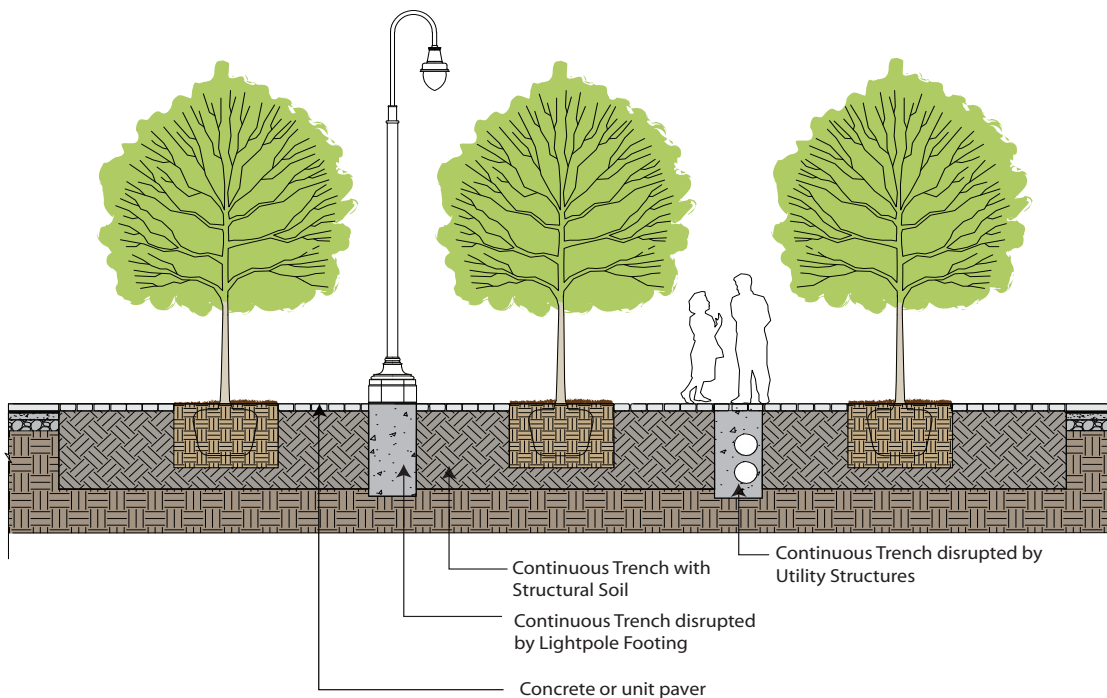

Continuous structural soil allows paving between individual tree pits

AMENDED SOILS

On-site soil is a natural resource that should be protected where future planting is envisioned. Importing soil to a project site can be expensive (1 cubic yard of topsoil costs approximately \$40) and carries with it other negative environmental costs including air pollution from trucking, traffic congestion, and the potential of importing invasive species or soil contaminants. Amending in-situ soil is the technique of adding natural components to compensate for poor physical or chemical soil properties. The goal is to create an ideal soil environment for expanding root systems, such that the soil has good aeration and

drainage, yet holds adequate moisture and nutrients for optimum root growth. Research shows that trees and shrubs grow outward approximately seven times the diameter of the root ball during the first year when provided with a good soil environment.⁷

During the site analysis phase of a project, existing soil need to be tested for its physical and chemical properties, as well as its percolation rate, to ascertain the composition of the parent material. Based on these test results an evaluation can be made as to which additives are necessary. Poorly drained soils can be improved in several ways. Sometimes deep cultivation will break apart a hard layer of soil (hardpan) to improve drainage. In other cases sand can be added to clay soils to increase porosity. Soils that tend to dry out (sandy soils) will benefit from organic matter incorporated uniformly throughout the planted areas. Fine mineral matter (sand) and organic amendments should be sourced from locally available facilities. Do not specify peat moss or other non-renewable resources.

During the design phase:

- Determine where planting is to occur and if existing vegetated areas can be preserved.
- Do not locate new utility lines that penetrate into these areas to save existing trees and protect the planting soils from construction disturbance.
- Prepare a site protection plan that delineates areas to be protected. Specify and draw durable barriers to surround these areas. Specify temporary erosion control measures if existing vegetation is to be removed.
- Specify correct proportions of amendments to achieve a good growing medium.
- Require individual component and post-installation soil tests to determine if the specifications have been met.

During construction – Specify that the contractor do the following:

- Protect future planting areas from compaction and incursion of contaminants generated by construction activities. Apply monetary penalties for violations if possible, as is done on DPR property by NYC Administrative Code 18-129.
- Perform soil amendment procedures in coordination with removal of invasive vegetation, erosion control measures, and subsequent permanent plantings.
- Utilize low ground pressure (LGP) operating equipment to minimize compaction. Use hand application methods at existing vegetation.
- Test amended soils for compliance with specifications prior to planting.

MAXIMIZE BIOMASS

Biomass is the term used to describe the total amount of living matter within a given unit of environmental area. Increasing biomass within the urban environment has many beneficial qualities, such as reducing air and noise pollution, reducing and treating stormwater runoff and soil erosion, mitigating the urban heat island effect, stabilizing the local microclimate, reducing energy usage in buildings for heating and cooling, improving public health, and creating pleasant streetscapes for the public. Because plants perform multiple positive environmental functions, there are numerous scientific methodologies for calculating these benefits, which range from total leaf surface area to the weight of decaying matter that accumulates within a vegetated area.

For example, large leaves tend to have more pores (stomata) per leaf that are important in the photosynthesis process. Similarly, more leaf area means more evapotranspiration, which introduces more moisture into the atmosphere. More leaf area also translates into more surface area to trap particulates. The goal, therefore, is to maximize areas of planting within a site. To do this in limited space requires a variety of plant species in a range of heights, so that one plant may be located within the canopy of another, as the example above of a narrow site shows.

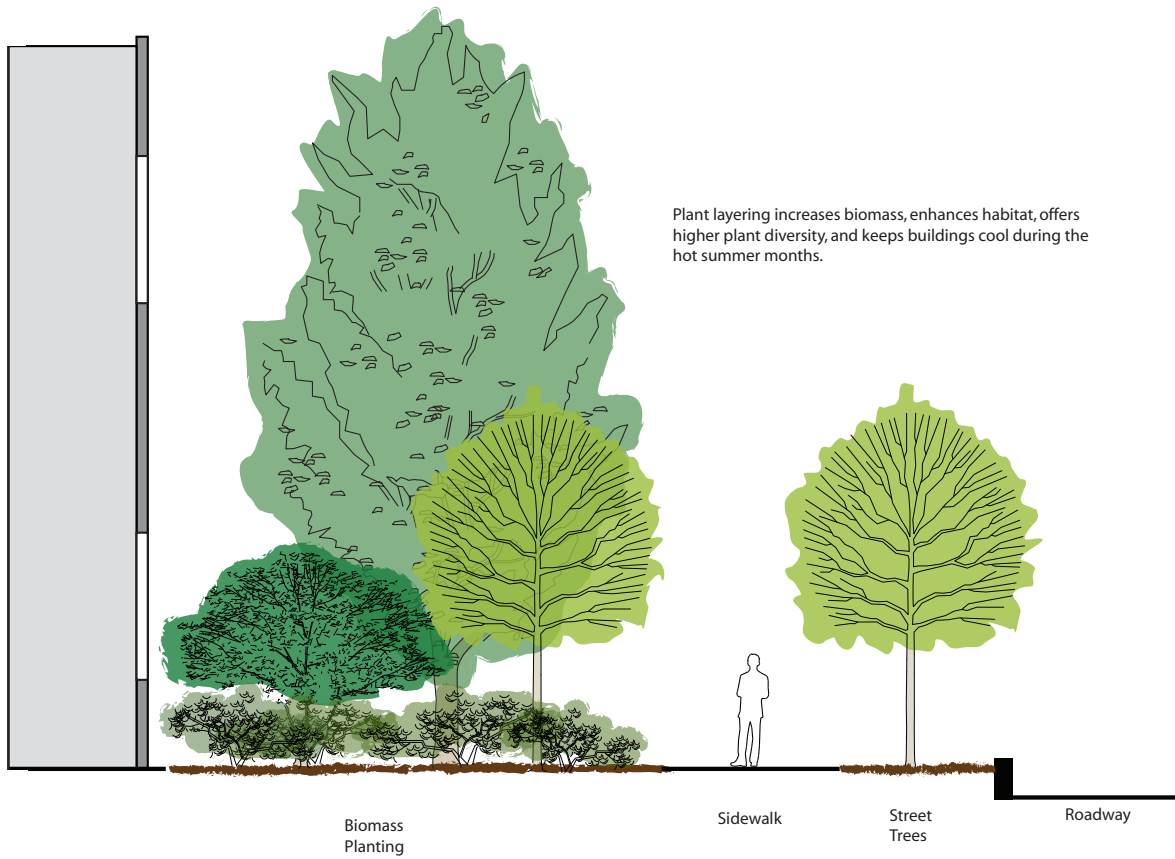

Biomass planting in a narrow site

Examples of locational opportunities include:

- **Sidewalk:** Maximize the number of street trees by coordinating above and below-ground utilities to minimize required clearances between trees and utilities; plant large canopy trees to provide maximum shade and leaf surface area; use continuous soil trenches to ensure adequate soil volume to encourage trees to mature to their full capacity.
- **Front yard:** If the building does not sit on the property line, use this zone as an opportunity to create a public plaza that might incorporate shade trees and areas of understory and herbaceous plantings.
- **Side yards:** These are ideal locations to locate dense buffers of planting that could serve to mitigate wind, shade south and west walls, screen service areas and maximize specie diversity.
- **Rear yard:** Depending on the building function, a rear yard could be a landscaped area for building occupants to enjoy; if it is used for parking, there are still opportunities to introduce shade trees and vegetated buffers (See chapter: Water Management).

Some of the best tree species for shade and large leaf area include: *Tilia americana* (American Linden), *Quercus macrocarpa* (Bur Oak), *Catalpa bignonioides* (Southern Catalpa), *Liriodendron tulipifera* (Tulip Tree), and *Gymnocladus dioica* (Kentucky Coffee Tree).

Some of the best understory and large shrubs that have either large leaves or dense foliage are: *Hydrangea quercifolia* (Oak-Leaf Hydrangea), *Ilex glabra* (Inkberry), *Itea virginica* (Virginia Sweetspire), *Clethra alnifolia* (Summersweet) and *Aronia arbutifolia* (Red Chokeberry).

Refer to the NYC Department of Parks and Recreation *Tree Planting Standards* for a more complete list.

TURF ALTERNATIVES

Conventional landscaping frequently uses lawn as a seemingly low cost, low maintenance solution to planting. Turf areas are actually expensive to maintain and carry with them high environmental costs. Turf requires considerable chemical intervention in the form of fertilizers, pesticides, and herbicides that contribute to water pollution. Increased levels of phosphorous and nitrogen (used in lawn care) cause rapid aquatic growth and subsequent decomposition, depriving fish and other aquatic life of oxygen, thus causing an eventual failure of a natural ecosystem. Studies show that concentrations of nitrogen and phosphorous have doubled in the last century.⁸

Reduction in turf areas in favor of native, low-maintenance landscapes can help reduce the amount of landscape-related pollutants entering natural systems. And by using deep-rooted ground covers instead of shallow-rooted turf grasses, water quality can be improved by slowing stormwater, encouraging infiltration, and capturing pollutants carried by runoff. A turf area requires at least 1 inch of water per week, which frequently must be applied by irrigation. By contrast, native grasses and drought tolerant ground covers can withstand up to three weeks of no rainfall without ill effects. Ground covers can be planted on slopes steeper than 1:3 which is the limit for a lawn mower. Ground covers are very effective in narrow or small areas or locations inaccessible to a mower.

Very few DDC projects have active recreation settings that need turf, and typically turf alternatives should be explored. Some of these alternatives include:

Herbaceous ground covers and “steppables”: These are perennial plants that remain low to the ground and can withstand occasional pedestrian traffic. They do not require pruning, mowing or chemical applications to remain viable. Many are evergreen, others are drought tolerant and still others provide seasonal interest. Particularly useful “steppable” species include: *Thymus praecox* (Creeping Thyme), *Arenaria verna caespitosa* (Moss Sandwort), and *Cerastium tomentosum* (Snow-in-Summer). Evergreen species include: *Vinca minor* (Periwinkle), *Liriope* (Creeping Lilyturf), and *Asarum caudatum* (British Columbia Wild Ginger). Drought tolerant species include: *Achillea tomentosa* (Woolly Yarrow), *Sedum* (many varieties), *Arcostaphylos uva-ursi* (Kinnikinnick), and many varieties of Juniper. Ground covers with seasonal interest, in addition to many of the above, include: *Ajuga reptans* (Carpet Bugle), *Hypericum calycinum* (Aaron’s Beard), *Cornus canadensis* (Bunchberry), Blue Rug Juniper and *Evonymus coloratus*.

Native grasses and “no-mow” lawns: These are native grasses that grow to a maximum height of 12 to 14 inches and only need to be mowed at the end of the growing season. Annual mowing in the autumn helps control invasive weeds and woody plants from taking root. No-mow lawns do not require chemical applications and can sustain periods of drought. Though their foliage may turn prematurely brown, their deep root systems allow them to rejuvenate after a rainfall. Grass species that qualify as “no-mow” lawn include hard fescue, chewing fescue, sheep fescue, and the native red fescue.

For information on specific varieties, specifications for installation and maintenance refer to www.bbg.org/gar2/topics/sustainable/handbooks/lawns/4.html

LAWNS AND POLLUTION

- Lawn mowers pollute as much in one hour as driving 350 miles.
- \$5.3 million is spent annually in USA on lawn fertilizers derived from non-renewable fossil fuels.
- One thousand square feet of lawn requires 624 gallons of water/week.
- A 1000 SF bluegrass lawn requires 6 pounds of nitrogen fertilizer/year.



Succulent low water groundcover



Woodland groundcovers for shade

photo: Mathews Nielsen Landscape Architects

photo: Mathews Nielsen Landscape Architects

Wildflower meadows: These are mixtures of native grasses and wildflowers that can be customized to specific microclimatic conditions including dry slopes, wet or shady areas, or poor soils. Wildflower meadows are particularly effective for habitat enhancement as they provide both food and shelter for birds, insects and small mammals. The base grass seeds that typically comprise 40-60% of the mix should be selected based on germination rate as well as microclimatic conditions to minimize weeds. The wildflower component may include a variety of species that extend colorful bloom time for several months. For information on specie selection, meadow establishment and maintenance, refer to, www.uvm.edu



Photo: Mathews Nielsen Landscape Architects

Native grass meadow with wild flowers

Mulches: Some site areas may not lend themselves to planting yet do not have to be paved. In such instances, there are a variety of mulches that can be used. Mulches are either organic or inorganic products that permit water infiltration, suppress weeds and permit walking. Organic mulches help restore nutrients and soil porosity through decomposition. Mulch also moderates temperatures, keeping soil warmer in winter and cooler in summer. Areas suited to mulches include narrow parking islands, areas under mature trees or densely vegetated locations. Types of organic mulches include: wood chips, composted leaf litter, peanut and coconut hulls and other organic by-products that do not contain components harmful to plant growth. Inorganic mulches include: ground recycled glass, pea gravels and other small stones, and compacted stone dust.



Photo: Mathews Nielsen Landscape Architects

Pine needle mulch

WINDBREAKS

Wind may be intercepted, diverted or lessened by obstructions such as buildings, walls, fences, earth forms, or plants. Buildings produce turbulent airflow as air moves around building corners; several buildings together can create a condition known as a wind tunnel, which can be uncomfortable. Unhindered, moving air generally flows in parallel layers. Wherever the wind flows over a vertical surface, the layer of air generally speeds up, creating a low pressure zone on the leeward side. A pierced screen such as a slatted fence or plant buffer allows some wind to penetrate through it, causing less pressure differential and providing a greater wake of protection on the leeward side.



Photo: Mathews Nielsen Landscape Architects

Windbreak with deciduous shrubs and coniferous trees

Plants control wind by obstruction, guidance, deflection, and filtration. Coniferous and deciduous trees and shrubs used individually or in combination affect air movement. Plants may be used in conjunction with landforms and architecture to alter airflow over the landscape, and around, or through buildings.

Strategic use of windbreaks can reduce heating loads in winter and direct cooling breezes into operable windows summer to reduce cooling loads.

Coniferous evergreens that branch to the ground are generally the most effective year-round plants for wind control; deciduous shrubs and trees are most effective in summer, when in leaf. A penetrable windbreak has a lower percentage of nearby wind reduction, but the overall calming effect extends a greater

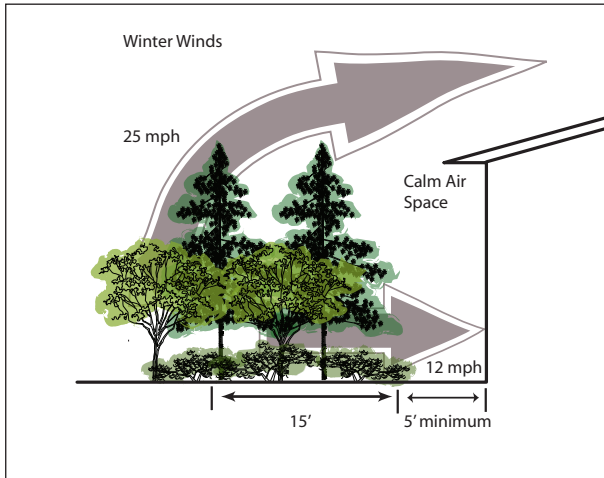

Windbreaks slow winds and reduce winter heating loads

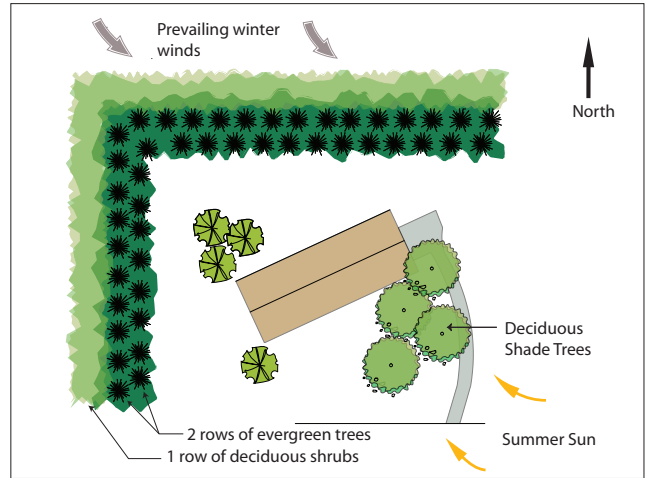

An effective windbreak is perpendicular to the prevailing winds, with layered vegetation

distance than if the barrier were impenetrable. The optimum density for a windbreak is about 60 percent. This means that leaves, trunks, and branches should cover 60 percent of the frontal area of the barrier. Vegetated windbreaks are most effective when placed perpendicular to the prevailing winds.

The zone of wind reduction on the leeward and windward sides of the barrier is largely dependent on the height of the barrier. The taller the trees, the more rows of trees are required for protection. A windbreak comprised of trees of varying heights is more effective than one of uniform height as the air stream is broken up as the wind is deflected over the trees. When using only evergreen plants, two to three rows of trees are adequate. When using deciduous material, four to five rows are necessary. Space evergreen trees 6 to 8 feet apart and stagger them if planting more than one row. When several rows are used, rows should be 12 to 20 feet apart depending on the mature size of the plants.

Effective species for evergreen windbreaks include species of the *Abies* (Fir), *Picea* (Spruce), *Pinus* (pine), and *Juniperus* (Juniper) groups. Effective species for deciduous windbreaks include *Catalpa* (Catalpa), *Cercis* (Redbud), *Cornus* (Dogwood), *Gymnocladus* (Coffee Tree), *Quercus* (Oak), and *Populus* (Poplar). When selecting species it is important that the plant itself be wind tolerant otherwise it will suffer from desiccation, leaf damage or create hazards from broken limbs.

VINE SCREENS

There are a variety of ways to reduce heat gain within a building. In addition to glazing solutions, interior shading solutions, and insulation, vine screens can be effective in reducing heat transmission. Vine screens can either be free standing or building mounted. In addition to providing shade, vine screens reduce ambient temperature through evapotranspiration and can lower interior temperatures through operable windows. Vine screens can have other advantages including obscuring undesirable views and contributing seasonal color and fragrance for building occupants.

When considering a free standing or building mounted vine screen, the key considerations are the amount of soil volume available to support large vines, the solar orientation to be screened, and the growth characteristics of the vine. Vines do not require soil depths greater than two to three feet, but they do need at least 60 cubic feet of soil to supply them with moisture and nutrients. This is generally easy to accomplish when the vines are planted at grade but becomes more challenging if vines are grown in planters on balconies or vertical structures.



Vine Screen – City Walk, CA.

Photo: Green Screen

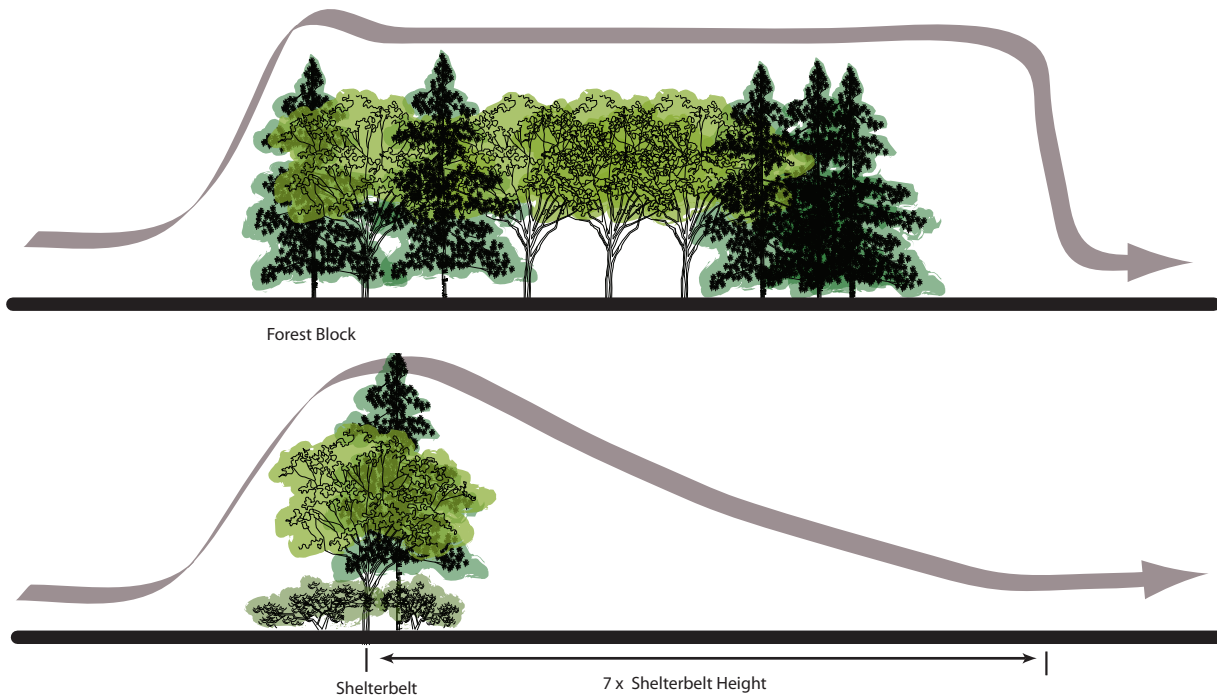

Wind abatement behind a forest block compared to with extended leeward of an efficient shelter-belt

A penetrable shelter-belt extends the calming effect for a greater distance than a dense windbreak. In the New York City climate, vine screens are most effective when used to block southern or western exposures. A study of the post-construction solar condition of a site will help determine the best locations for such screens. Blocking the high angle of the summer sun against a building in excess of three stories will require locating vines at multiple intervals along the vertical face of a façade as most vines do not exceed 30 feet in mature height. Intercepting the lower angle of the western sun is more easily achieved with a freestanding vine screens or a vertically mounted trellis.

Vines are classified as twining, climbing or clinging. Twining vines grow by ascending toward light using tendrils that wrap around a vertical rod or cable. Climbing vines need to be trained to grow vertically by human intervention. These vines require periodic tying of new growth to ensure that the vine remains in contact with the supporting structure. Clinging vines adhere to vertical surfaces using aerial roots and are not recommended due to problems associated with building maintenance. Some clinging vines can be trained as climbers if the vertical structure is kept at least 12 inches away from the façade.

Twining vines require a series of spaced vertical cables or rods, generally spaced 12 inches on center. The rod or cable width should not exceed two inches to ensure that the tendril can effectively wrap around it. The one exception is Wisteria, which can twine around a much larger vertical. Wisteria can grow up to 60 feet in height but as it matures it is both very heavy and capable of crushing hollow tube frames. Horizontal cables or rods can also be used to encourage a vine to spread laterally; the same spacing is recommended. Some vines are considered very “opportunistic” and will rapidly spread beyond their intended boundaries so caution should be used when placing trees near vines. There are a number of prefabricated vine screens and wire rope manufactured for free standing or building-mounted trellis systems.

Particularly useful species are:

- Twining deciduous vines for screens mounted to building facades: *Clematis paniculata* (syn: *Clematis maximowicziana* or *Clematis ternifolia*) Sweet Autumn Clematis, *Lonicera japonica* (Japanese Honeysuckle), *Actinidia arbuta* (Bower Actinidia), *Akebia quinata* (Five-Leaf Akebia), and *Polygonum aubertii* (Silverlace Vine).

- Climbing or clinging deciduous vines for free standing screens: Rosa species (Climbing Roses), Campsis radicans (Trumpet Creeper), Parthenocissus tricuspidata (Boston Ivy) or Parthenocissus quinquefolia (Virginia Creeper), and Hydrangea petiolaris (Climbing Hydrangea).
- Clinging evergreen vines for free standing screens: Hedera helix (English Ivy), and Euonymus fortunei (Wintercreeper).

Plant selection will depend on solar exposure, ultimate desired height of the vine growth and the medium on which the vine is to be secured. Some of these vines can be considered aggressive; evaluate the site context before selecting.

HABITAT ENHANCEMENT

The magnitude of global biodiversity loss is one of the most significant environmental issues of our time. Urban development has resulted in a fragmented ecosystem wherein many species have become isolated within small patches of habitat. Even within New York City there is the opportunity to enhance habitat for desirable species of insects, birds, aquatic life, and small mammals. The City is part of a larger ecosystem that needs to maintain biodiversity, which prevents extinction and maintains essential genetic diversity. Certain habitats, particularly wetland and riparian ones, not only benefit particular faunal species, they also serve to filter and cleanse stormwater runoff and act as natural flood control. The goal of habitat enhancement is to reconnect these isolated areas such that faunal species can find food and shelter to survive and reproduce.

A biological corridor can be defined as a strip, swath or other functional habitat that allows species to move between otherwise isolated patches. These corridors may be used regularly by species, or come into play during times of need, such as a drought. Corridors provide for dispersal when animals or plant seeds travel between populations and when genetic material flows between populations through breeding. Dispersal is essential to the maintenance of healthy populations, particularly in fragmented landscapes.

Corridors must be designed with careful consideration to the goals and biodiversity issues of the given locale. When designing a habitat corridor, evaluation of its placement and larger context is critical. For example, butterflies prefer habitats within 200 feet of each other, so providing even a small patch is helpful. Migrating birds, on the other hand, can fly hundreds of miles, but they too benefit from feeding stopover locations. Yet other species, particularly those associated with wetland and riparian ecosystems, utilize the corridor for shelter and breeding.

Habitats with native vegetation should be included to encourage movement of native species within the corridor. A network of redundant corridors providing multiple linkages between habitat patches is ideal. Habitat corridors should be as wide as possible and removed from edges, such as sidewalks and parking lots, which suffer from degradation by pollutants and people. Even a small site can contribute, especially a rear or side yard that abuts a park, a wetland protection zone or a neighbor’s open space.

Strategies for habitat enhancement are:
During Planning and Design:

- Analyze the existing site and its adjacent vegetated open spaces to understand the types of flora and fauna that can benefit from habitat enhancement proportioned to the scale of the site.
- Engage the client agency and local stakeholders in the design process to manage expectations and encourage education about the benefits.
- Avoid major alterations to the site’s topography, drainage patterns and viable stands of vegetation to protect the existing ecosystem.
- Select plant species by associations found locally that will promote ecological diversity and habitat.

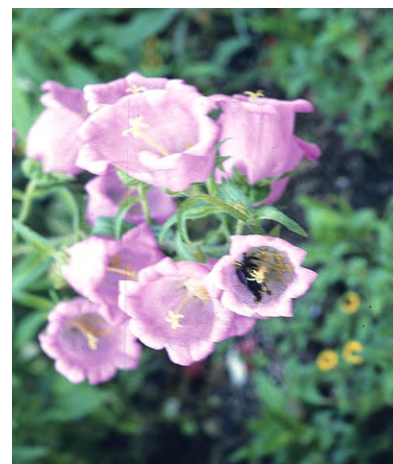

Biodiversity enhances habitat

Photo: Mathews Nielsen Landscape Architects

- Coordinate planting and grading design with stormwater design to offer additional opportunities for habitat. See Water Management chapter.

During Construction – specify that the contractor do the following:

- Sequence construction activities to minimize adverse impacts to existing soils, vegetation and drainage patterns. See Minimize Site Disturbance chapter.
- Develop and enforce a site protection plan. See Minimize Site Disturbance chapter.
- Treat future planted areas to remove invasive species. Refer to DRP specifications for Phragmites removal.



photo: Mathews Nielsen Landscape Architects

Appropriate plant selection improves water quality and habitat

Post Construction and Maintenance:

- Time landscape maintenance such as annual mowing of meadow grasses to ensure seeds are set and dispersed. Do not prune native species that produce flowers or seeds valuable to birds or butterflies. Do not disturb natural areas during times of breeding.
- Remove invasive species at appropriate times to discourage encroachment and minimize disruption to valuable species. Use mechanical means rather than chemical agents to remove invasives.

RESOURCES

PLANT SELECTION

- <http://www.invasivespecies.gov/laws/congress108.shtml>

HABITATS

- www.americantrails.org
- www.city.ottawa.on.ca

TURF ALTERNATIVES / INTEGRATED PEST MANAGEMENT

- www.agnr.umd.edu
- www.ippc.orst.edu
- www.udel.edu
- <http://cipm.ncsu.edu/index.html>
- www.attra.ncat.org
- <http://environmentalrisk.cornell.edu/PRI/RedRisk-BMP.cfm>

NYC LAWS, RULES & REGULATIONS

- <http://www.nyc.gov/html/oec/html/about/aboutoec.shtml>
- www.nyc.gov/html/dcp/pdf/zone/art10co5.pdf

NYC DEPARTMENT OF PARKS AND RECREATION TREECOUNT

- http://www.nycgovparks.org/sub_your_park/trees_greenstreets/treescount/treecount_summary.php

GLOBAL WARMING EFFECTS ON PLANTS

- <http://yosemite.epa.gov/oar/globalwarming.nsf/content/ActionsLocalHeatIslandEffect.html>
- http://www.ghcc.msfc.nasa.gov/uhipp/epa_doc.pdf

VEGETATION BENEFITS

- http://www.appanet.org/treeben/calculate_p.asp
- <http://www.epa.gov/heatisland/strategies/vegetation.html>
- http://www.coolcommunities.org/urban_shade_trees.htm

STRUCTURAL SOIL

- “Positively the Pits : Successful Strategies for Sustainable Streetscapes,” by Karen Doherty, Tree Care Industry, November 2003.
- “Using CU-Structural Soil in the Urban Environment,” Urban Horticultural Institute, Cornell University. www.hort.cornell.edu/uhi/outreach/csc/index.html
- http://www.nycgovparks.org/sub_your_park/trees_greenstreets/treescount/treecount_summary.php

SAMPLE DETAILS

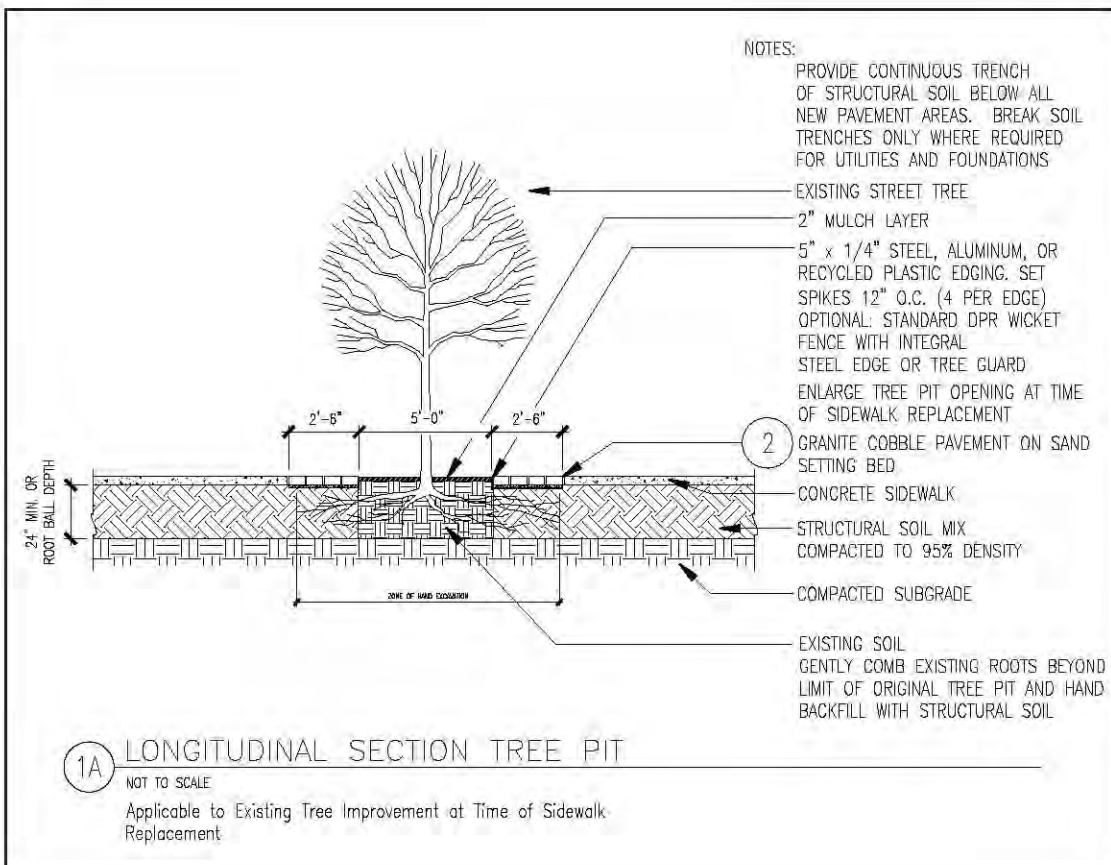
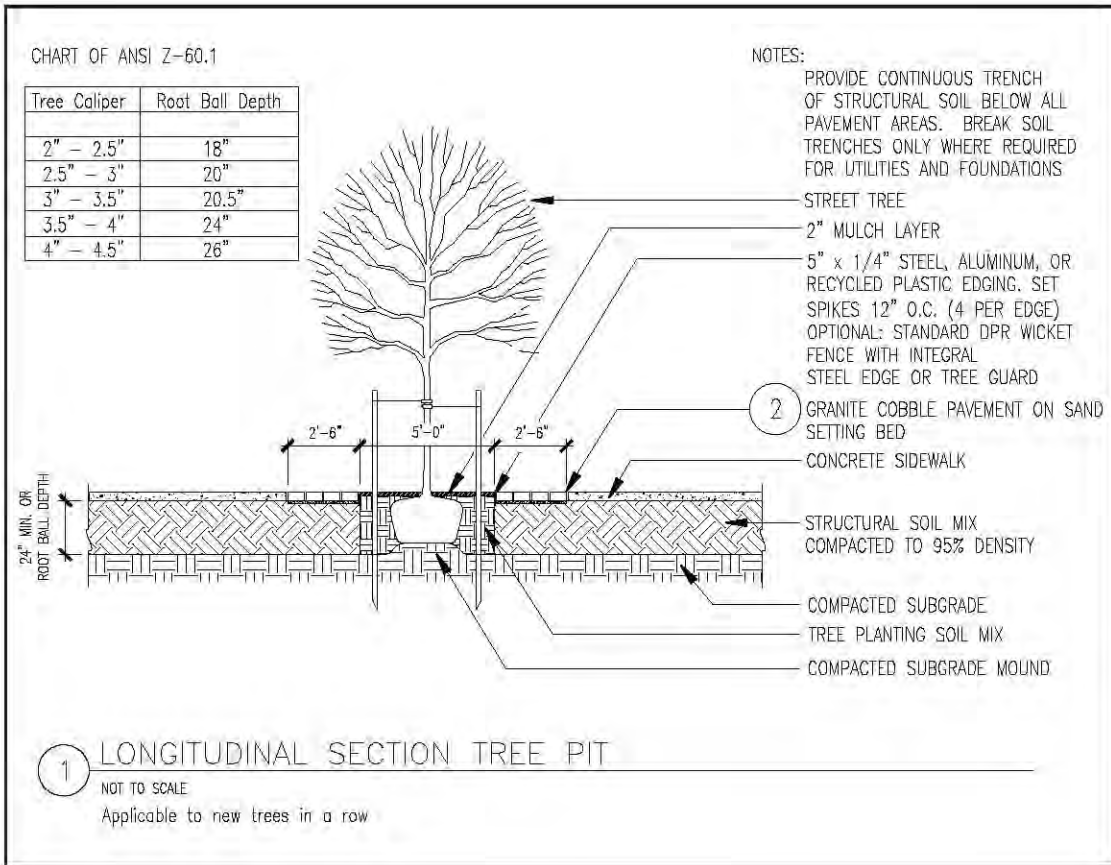

SAMPLE DETAILS

CHART OF ANSI Z-60.1

Tree Caliper	Root Ball Depth
2" - 2.5"	18"
2.5" - 3"	20"
3" - 3.5"	20.5"
3.5" - 4"	24"
4" - 4.5"	26"

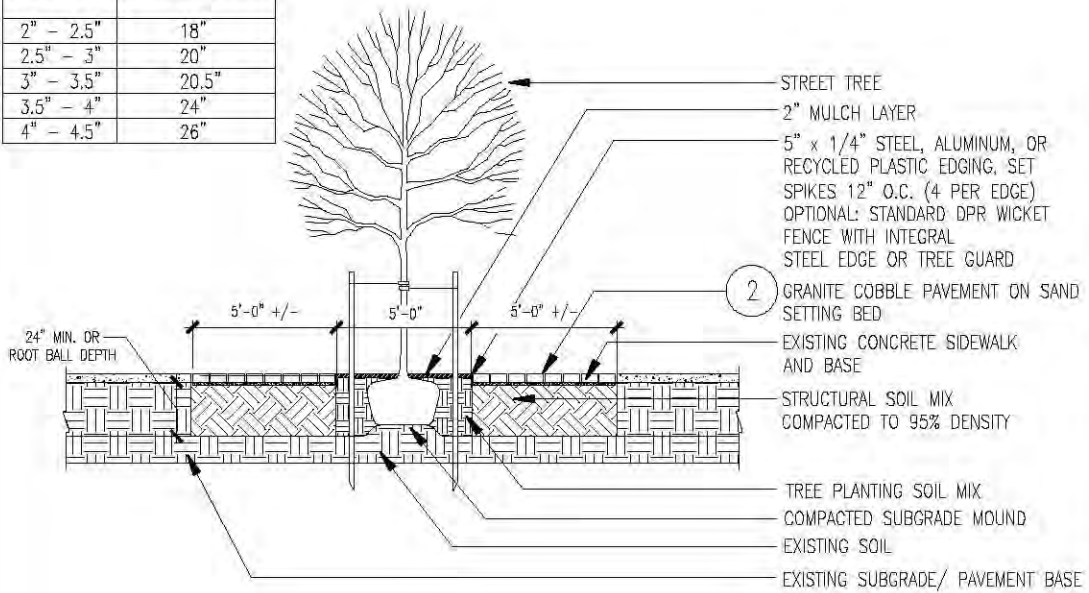

1B LONGITUDINAL SECTION TREE PIT

NOT TO SCALE

Applicable to Individual New Tree

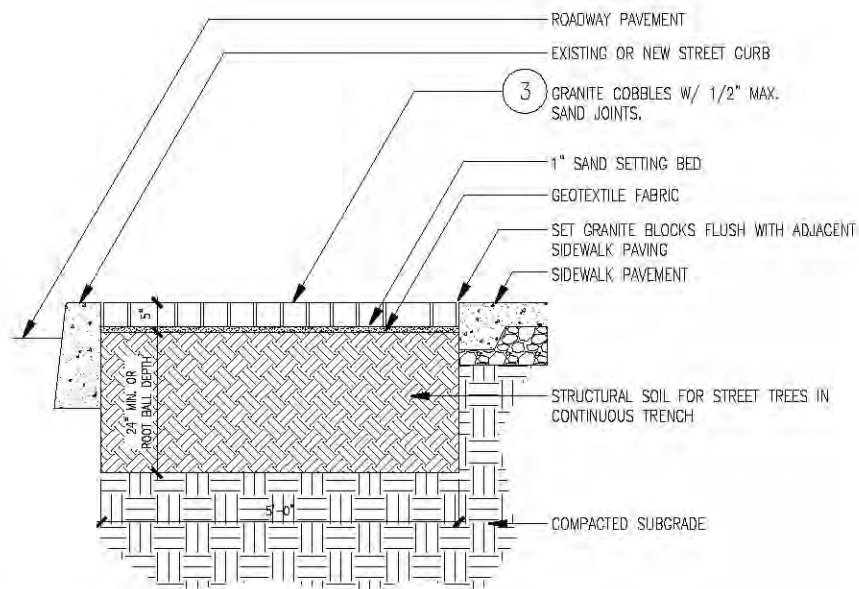

2 CROSS SECTION GRANITE COBBLE PAVING IN CONTINUOUS TREE TRENCH

NOT TO SCALE

Applicable to New Trees and Trench Between Existing Trees at Time of Sidewalk Replacement

SAMPLE DETAILS

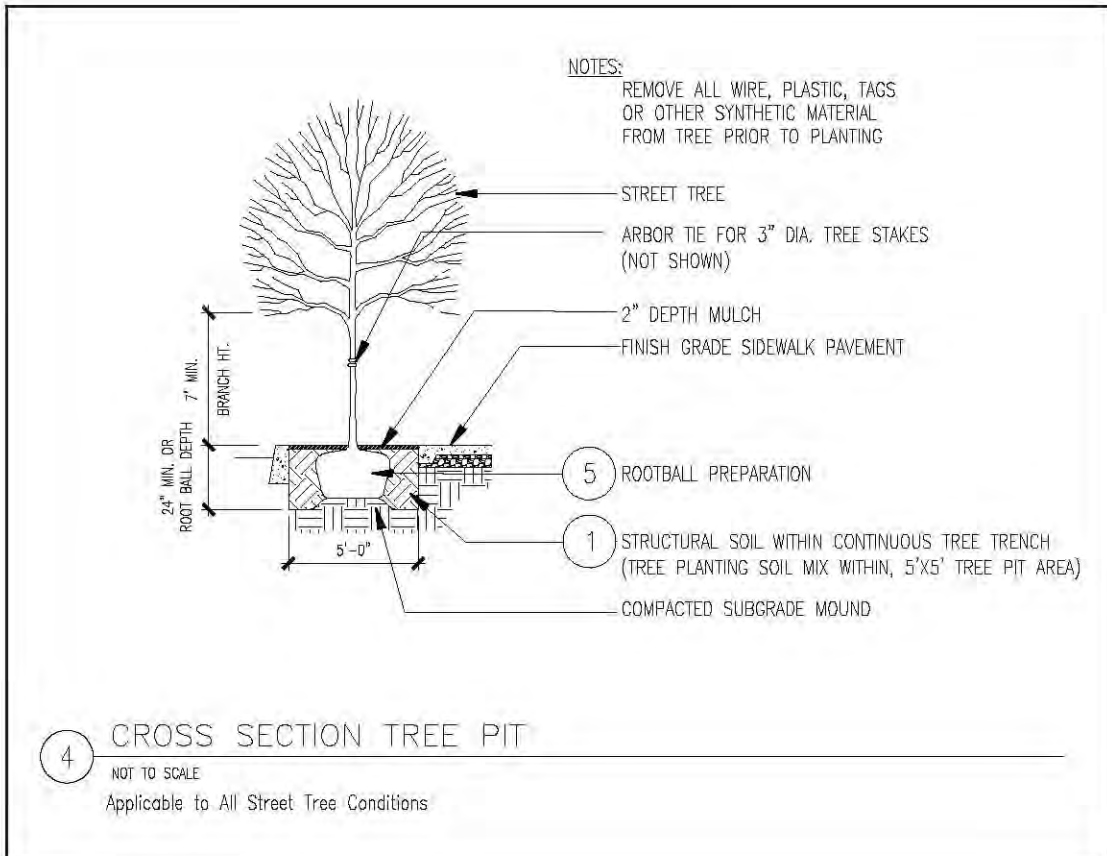
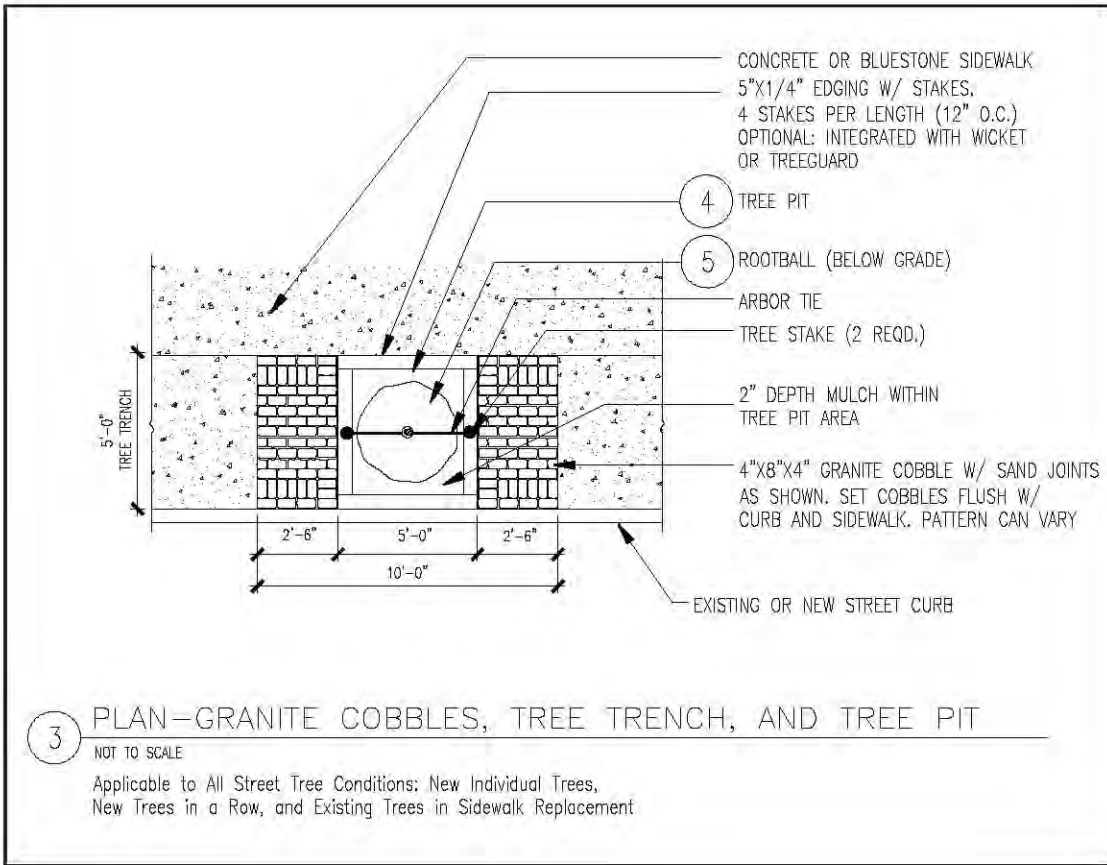

SAMPLE DETAILS

NOTES:

BALL SIZE (WIDTH AND DEPTH) AFTER REMOVAL OF EXCESS SOIL ABOVE THE ROOT/TRUNK FLAIR SHALL CONFORM TO THE AMERICAN STANDARD FOR NURSERY STOCK FOR THE CALIPER SIZE OF THE TREE.

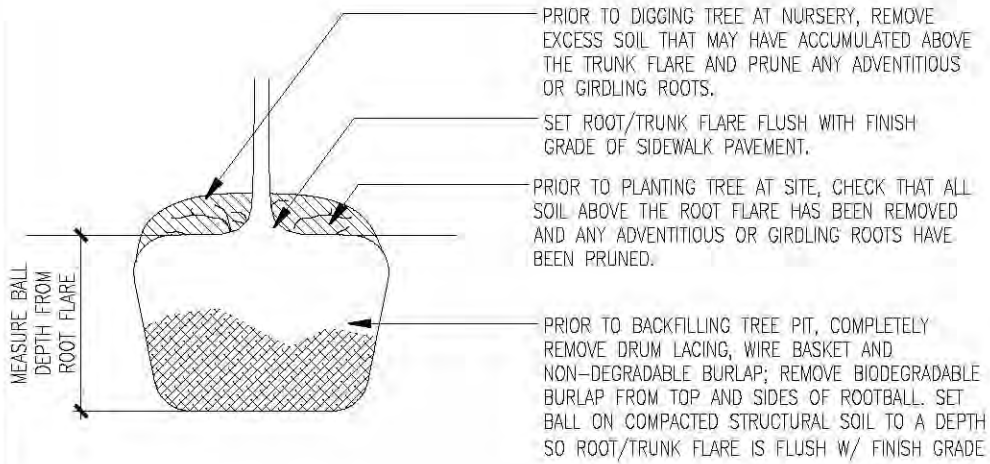

5 ROOT BALL PREPARATION

NOT TO SCALE

For All New Tree Planting



MINIMIZE SITE
DISTURBANCE

MINIMIZE SITE DISTURBANCE

This is a cautionary tale. Poor site design in conjunction with construction activity can seriously degrade a site, damage its vegetation and its potential for recovery. Soils, as well as plants, are fragile living systems and damage easily. Much of this harm is preventable, caused by a lack of planning and careless treatment. To minimize site disturbance, designers need to plan and prepare their documents with site characteristics in mind. Contractors need to understand that protections are expected, and their site use will not be unencumbered; and construction managers need to enforce site protection plans and related specifications.

Minimizing site disturbance is critically important. Soils and plant material are valuable resources that can be injured or destroyed if their complex interdependent systems are disrupted. It takes considerable planning and vigilance during the design and construction phases to ensure these site resources are protected, and to avoid expensive and environmentally destructive ramifications. Unnecessary destruction of mature plants, particularly trees, will incur high cost for their replacement; destruction of viable soils through compaction and erosion wastes money, harms existing vegetation, clogs waterways through sedimentation and adds dust to the atmosphere. There are high costs to import new soil, which generates associated environmental degradation from air pollution from trucking, community disruption, and potential importation of harmful material. Beyond the obvious long time that it takes for a tree to develop into a mature specimen, sustainable soils take even longer to regenerate.



photo: Mathews Nielsen Landscape Architects

Site disturbance during construction

Problems arising from construction-related site disturbance have been serious enough nationwide that in 1972 the federal government established the National Pollutant Discharge Elimination System (NPDES), a comprehensive program for regulating discharges into waterways, pursuant to the Clean Water Act. In 1990, US EPA developed the Phase I stormwater management program within NPDES, and in 1999 it developed the stricter Phase II program. EPA's regulations under the Phase I and II programs required municipalities, including New York City, to implement stormwater management programs. The NY State Department of Environmental Conservation (NYS DEC) in 2003 assumed jurisdiction for regulating stormwater discharge under the federal Phase II rules. Within New York City, Department of

Environmental Protection (DEP) regulations also restrict certain aspects of stormwater management. Currently, NYC is reviewing many of its stormwater management laws and regulations, pursuant to PlaNYC and Local Law 5 of 2008, as well as state and federal requirements. DDC and its consultants will need to comply with these provisions as they are revised. The requirements to obtain a construction permit are described in more detail in the Laws, Rules and Regulations section of this chapter.

As the City continues to grow, there is increasingly less land on which to build. As a result, new sites are frequently located on unstable fills, steep slopes, or post-industrial shorelines that may be contaminated by prior uses. These types of sites are particularly sensitive to site disturbance, and poor site design and construction methods can irreparably damage the interrelationship among topography, soils, drainage patterns, vegetation, and habitat of these sites. Some of the more damaging practices are:

- Pollution of NYC's water supply, resulting from improper use, handling, storage, transport and/or disposal of substances including pesticides, fertilizers, winter roadway maintenance materials, and construction-related contaminants
- Increased erosion from compacted or bare soil and concomitant sedimentation into streams and rivers, resulting in higher water levels, increased flooding potential, destruction of aquatic and shoreline habitat, and degradation of water supply
- Increased compaction of subsoils resulting in poor drainage, perched water table, and limited root growth
- Increased project costs to plant new vegetation that might otherwise have been saved or restitution payments to the NYC DPR for removal or damage to street trees

- Lack of understanding that damaged trees, even if ostensibly “protected” may take several years to die, leaving the burden of removal and replacement on the property use
- Increased project costs to import topsoil that otherwise might have been saved by stockpiling and protecting on-site topsoil
- Increased likelihood of transporting contaminated soils or foreign/invasive seed source in imported topsoil and fill materials
- Long term risk to people and property from trees damaged by construction
- Damage to community or neighborhood environmental quality by unnecessary destruction of mature vegetation
- Increased air pollution from dust generated by vehicles driving over unprotected bare soils
- Increased noise and community disruption from unnecessary trucking activities to deliver or haul materials that might otherwise have been reusable from on-site sources

LAWS, RULES AND REGULATIONS

Laws and regulations have been developed by governmental agencies in response to past and present environmental damage caused by construction-related activities. The two primary concerns are protection of the nation’s waterways, and prevention of further loss of vegetation and natural resources. The design team should be aware of the many regulations that cover site planning and construction in NYC, especially those projects that are near a water body or a freshwater or inter-tidal wetland. Key regulations are summarized below and described in the text.

SUMMARY – LAWS, RULES AND REGULATIONS

See text and web links below for more information

AGENCY	LAW, RULES, AND REGULATIONS 2008	APPLICABILITY
NYS Department of Environmental Conservation (DEC)	SPDES Permit Stormwater Pollution Prevention Plan (SWPPP) required as part of SPDES permit compliance	Sites greater than 1 acre, if site disturbed ¹ Additional requirements for sites over 5 acres and in certain other special circumstances
NYC Department of City Planning (DCP)	Special Natural Area District (SNAD) require special protections	Areas and requirements identified in NYC zoning code (NA overlay) – parts of Staten Island, the Bronx and Queens
NYC Office of Environmental Coordination (OEC)	Waterfront Revitalization Program (WRP)	Waterfront and coastal zone sites, designated by DCP
	City Environmental Quality Review (CEQR)	Discretionary action by project’s lead agency
	City Environmental Quality Review and related Environmental Impact Statement / Environmental Assessment Statement	When lead agency requires CEQR (above), OEC assists City agencies in carrying out CEQR documents
US Army Corps of Engineers (ACOE)	Section 404 Permit for wetlands (nationwide and local)	Projects within mapped wetlands or coastal zone
NYS Department of State Coastal Zone Consistency Review	Waterfront Revitalization of Coastal Areas and Inland Waterways Act (Executive Laws Sections 910-921)	Projections that fall within any one of the 15 Significant Coastal Fish and Wildlife Habitats in New York City or within the 100-year floodplains

¹ Clearing, grading, excavating, disturbing soil or placement of fill. Per NYS DEC “Stormwater Management Guidance Manual for Local Official,” Appendix 5, p.1

Web links – Note that full regulations not always available on-line.

US Army Corps of Engineers www.usace.army.mil/inet/functions/cw/cecwo/reg/

NYS Department of Environmental Conservation

www.dec.state.ny.us/website/dow/toolbox/ms4toolbox/local.html

NYC Department of Environmental Protection

www.ci.nyc.us/html/dep/watershed/html/regulations.html

NYC Department of City Planning

Waterfront Revitalization Program www.ci.nyc.ny.us/html/dcp/html/wrp

Special Natural Area District www.nyc.gov/html/dcp/html/snad/index.shtml

CEQR Technical Manual – document available

NYC Office of Environmental Coordination www.nyc.gov/html/oec

State Pollutant Discharge Elimination system (SPDES): Controlling stormwater runoff is an important component of maintaining and improving water quality and ecosystem health in New York City. In some parts of the City, stormwater run-off flows directly into waterways by means of separate storm sewers, carrying with it sediment and chemical pollutants. The majority of the City has a combined storm-sanitary sewer system, such that stormwater normally flows to Water Pollution Control Plants (WPCPs) for treatment along with sanitary sewerage. However, heavy precipitation can lead to Combined Sewer Overflows (CSOs), in which run-off exceeds WPCP capacity and forces untreated discharges of stormwater and sanitary sewerage.

NYS DEC has adopted a SPDES General Permit for Stormwater Discharges from Construction Activity (GP 0-08-001) so as to control waterway-polluting run-off from construction sites and developed sites. NYS DEC adopts and enforces SPDES Permits in New York State based on a delegation of authority from the US EPA. General Permit 0-08-001 expires in 2010, and is likely to be replaced at that time with another general permit. Currently, NYC construction projects greater than one acre in size, where there will be any site disturbance such as excavation, clearing, grading or fill, must apply to NYS DEC for certification that the project will comply with the SPDES General Permit. NYS DEC also has jurisdiction to require certification of smaller sites where water quality is of particular concern. There are limited exceptions to the certification requirement for routine maintenance activities. Certain major construction projects are ineligible for certification under the General Permit, and must instead complete a more detailed application and obtain an Individual Permit from NYS DEC.

To obtain General Permit certification, the project sponsor must do the following:

- Develop a Stormwater Pollution Prevention Plan (SWPPP), following the requirements of the New York State Stormwater Management Design Manual (www.dec.ny.gov/chemical/29072.html). The SWPPP must contain an erosion and sedimentation control plan for construction plus proposed measures to control run-off pollution after the construction is complete.
- Submit a Notice of Intent (NOI) to DEC in Albany. A copy should also be sent to the DEP Bureau of Wastewater Treatment, attn: Chief, Pollution Prevention Section.
- If the plan conforms to the Design Manual, construction may begin after a five-business-day authorization period.
- If the SWPPP deviates from the Design Manual, the plan must be certified by a design professional and submitted to the regional DEC office for a 60 day review period.

Operators of construction sites must create and abide by the prepared Stormwater Pollution Prevention Plan (SWPPP) governing the management of stormwater during construction and post-construction and must construct any needed stormwater management facilities as specified in the NYS Stormwater Management Design Manual. The “operator” for the permit process is the legal entity that owns or leases the property on which the construction activity will occur – the City of New York for DDC projects.

Information necessary to prepare and submit a SWPPP is described in NYS Department of Environmental Conservation SPDES Permit GP 0-08-001, available at http://www.dec.ny.gov/docs/water_pdf/conspemito8.pdf.

A partial list of required information includes:

- Listing of areas of disturbance and protection, existing vegetation, modifications to drainage patterns that could be affected by construction activity, and final grading;
- Description of in-situ soils;
- Construction phasing plan and extent of site disturbance resulting from the sequence of construction activities;
- Description of pollution control measures;
- Description of construction and waste materials expected to be stored on-site and associated measures to control their potential for pollution;
- Description of temporary and permanent structural and vegetative measures to be used for soil stabilization, runoff and sediment control for each stage of the project.

Projects that have obtained certification under the General Permit must be inspected regularly during construction by a trained professional to ensure that the erosion and sedimentation controls are functioning properly.

Special Natural Area Districts: Special Natural Area Districts (SNAD) are sensitive ecological zones identified by NYC and delineated as an overlay in the NYC Zoning Resolution. The purpose of SNAD is to protect natural features by limiting modifications to topography, vegetated areas, marine life, and water courses. Within these zones, all new public and private structures require authorization or a special permit from the NYC Department of City Planning (effective December 2004, with private residences grandfathered). Mapped SNAD's are located in Community Districts 1 and 2 in Staten Island, Community District 8 in the Bronx, and Community District 7 in Queens. Check the website of the NYC Department of City Planning for the latest information.

Other Regulations: A specific DDC project may be subject to other regulations about site disturbance, depending on the location or environmental sensitivity. Certain projects will be required to prepare Environmental Impact Assessments or Statements and undergo City Environmental Quality Review (CEQR). These are discretionary actions by the Department of City Planning and the lead agency, and will be part of the project's initial scope.

Contaminated Sites: The DDC, through the Environmental and Geotechnical Services Unit, offers free-of-charge services for testing and assessment of contaminated and hazardous soils for any DDC Structures project. The process is broken into two phases. Phase I is a site assessment based on a study of prior site usage to determine the likelihood of contamination. If historical records do not reveal likely activities that could result in contamination, no further study is conducted. If records point to a probability of contamination, soils are tested as Phase II. DDC now recommends that all sites perform routine testing as part of Phase I because the presence of harmful metals, petroleum products, pesticides and VOC's, is significantly more likely in urban areas.

NYS DEC is the agency that determines acceptable / unacceptable levels of contamination; check their web site for testing protocol and required action.

Archaeology: Urban archaeology is the systematic recovery and examination of material evidence from the City's past. Because of the irreplaceable nature and historic value of archaeological resources, they are protected by the city, state, and federal laws. NYC Landmarks Preservation Commission (LPC) governs the review and approval process for all projects that impact archaeological resources. The LPC is in the process of creating a GIS map to track archaeological research in New York City, which will serve as a guide to a site's likelihood of containing historic features. Although most projects do not trigger archaeological concerns, the team should have an initial review with LPC staff archaeologists at the outset of any project with excavation, to determine whether a project will require a formal procedure. The Landmarks Preservation Commission Guidelines for Archaeological Work in New York City is available on their website.

Scenic Landmarks: A scenic landmark is a landscape feature or group of features that have been designated by the Landmarks Commission. Scenic landmarks are only situated on city-owned property and require special review and approval if the context around a designated site is proposed to be altered. Examples of designated scenic landmarks are Prospect Park, Verdi Square, Central Park, and Ocean Parkway.

LEED AND SITE DISTURBANCE

With the enactment of Local Law 86 of 2005, the City now requires most of its projects to meet the Silver level of the LEED certification process of the U.S. Green Building Council (USGBC). The Sustainable Site Prerequisite has a strong link to the practices recommended in this chapter and to the requirements of the SPDES process. The NC2.2 site prerequisite requires the preparation and implementation of an erosion and sedimentation plan, conforming to the 2003 EPA General Construction Permit or local requirements, whichever are more strict. In addition to the prerequisite, one design and construction credit is Site Development Credit 5.1, which limits the extent of site disturbance on all greenfield sites (not previously developed and remaining in a natural state) or requires restoration/protection on a previously developed site. Recommended LEED strategies parallel those in this chapter.

LEED CREDITS

Minimizing Site Disturbance can contribute to the following LEED NC credits:

Sustainable Sites:

- Credit SS P1 – Construction Activity Pollution Prevention
- Credit SS 2 – Development Density & Community Connectivity
- Credit SS 3 – Brownfield Redevelopment
- Credit SS 5.1 – Site Development Protect or Restore Habitat
- Credit SS 6.1 – Stormwater Management Quantity Control
- Credit SS 6.2 – Stormwater Management Quality Control

LEED and SPDES: Construction Activity Pollution Prevention is a prerequisite under LEED Sustainable Sites (NC v 2.2), and extends NPDES [Federal] requirements for construction activities, which currently apply to projects 1 acre and larger, to all projects pursuing LEED certification. Because a New York City project requires a SWPPP (Storm Water Pollution Prevention Plan) under the State SPDES permit, the only additional LEED actions are to submit the Plan as part of the Construction Submittal and document that SPDES is equal to or more stringent than the referenced Federal NPDES.

KEY ISSUES IN MINIMIZING SITE DISTURBANCE

SOIL COMPACTION

Soil compaction occurs when soil particles are pressed together, reducing pore space between them and increasing their bulk density. Although desirable under structures, compaction is destructive to soils that support vegetation or facilitate stormwater control. In urban areas, the two most prevalent causes of harmful compaction are foot traffic on developed sites and construction vehicles on developing sites. Heavily compacted soils contain few large pores and have a reduced rate of both water infiltration and drainage from the compacted layer. Soil compaction leads to stunted, drought-stressed and disease-susceptible plants because of low oxygen concentration, decreased root growth, and moisture irregularity. Compacted soils have lower infiltration rates than undisturbed soils and are more prone to erosion and sedimentation. Vehicles driving over dry soils will exert compaction within the top 12-15 inches of soil, whereas on wet soils, the effect of compaction is deeper than 18 inches (Voorhees, et al., 1986). As the depth below grade of compaction increases, the more persistent and difficult it is to remediate the soil. Soil compaction during construction can be prevented; see the Techniques section for design details and specification suggestions.

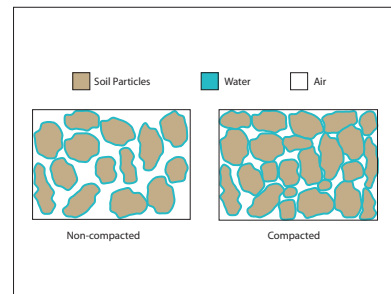

Compacted soils cause long term damage to existing or proposed vegetation

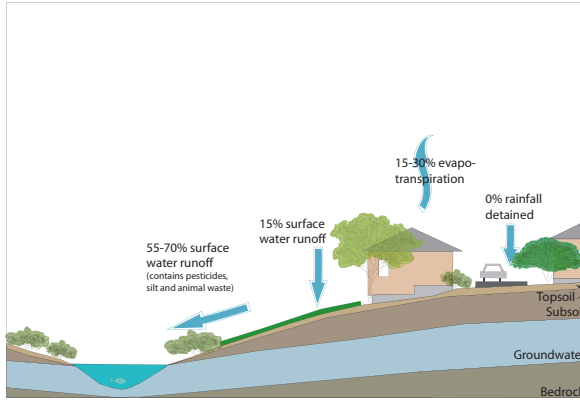

Water movement on a disturbed landscape with limited vegetation

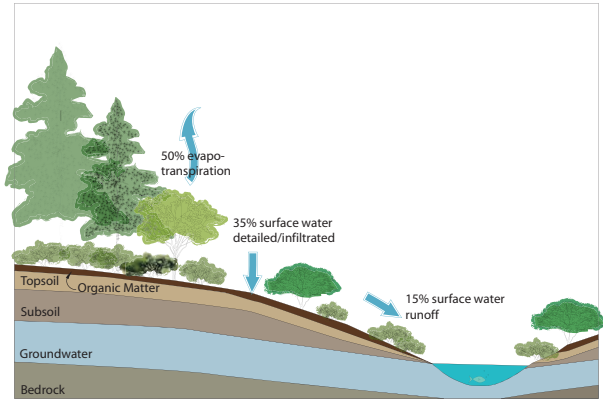

Water Movement on a natural landscape with plant cover

SOIL EROSION AND SEDIMENTATION

Erosion and sedimentation are interrelated problems caused by stormwater runoff. Stormwater flowing over a construction site carries soil particles from the surface, including valuable topsoil. Eroded soil becomes sediment, creating adverse impacts on water quality, critical habitats, submerged aquatic vegetation beds, recreational activities and navigation, especially in coastal areas. Additional pollution occurs when eroded soil contains debris or chemicals.

Runoff from construction sites is by far the largest source of sediment in urban areas. For this reason the NYC Department of Environmental Protection (NYC DEP) and NYS Department of Environmental Conservation (NYS DEC) require projects to obtain approvals and/or permits for construction that will alter a site's natural or pre-existing condition. The rules and regulations of NYC DEP are intended to minimize the discharge of pollutants into source waters, minimize the adverse impacts of erosion, and regulate activities that may cause contamination or degradation of the water supply.

Soil erosion by water depends on the slope of the land (steeper = more susceptible), soil structure (light soils = greater likelihood) and volume or rate of flow of surface water (larger/more rapid flows = greater transport). Susceptibility to erosion is also a function of soil exposure (lack of vegetation).



Example of gully erosion

photo: Mathews Nielsen Landscape Architects

Wind erosion, the movement of soil particles by wind, occurs when land surfaces lack vegetation and the soil dries out. Smaller and lighter soil particles move most easily – just the type of particles that form when construction vehicles pulverize soil under dry, windy conditions.

DAMAGE TO TREES AND VEGETATED AREAS

Trees can be damaged or killed by a wide variety of construction activities. Some practices lead to obvious injuries such as broken branches or torn bark. Open wounds of this type deplete a plant's energy and provide entry points for insects and diseases. The worst damage, however, often remains hidden underground. Roots are one of the most vital parts of a plant and must be protected from construction activities. They are responsible for water and nutrient uptake, store energy, and anchor the plant. Trees are never the same shape below ground as they are above, so it is difficult to predict the length or location of their roots. Typically, however, 90-95 percent of a tree's root system is in the top three feet of soil and more than half of it within the top 12 inches. The part of this root system in which construction damage should be avoided is called the Root Protection Zone (RPZ).

One common method used to identify the RPZ is to define the drip line – the area directly below the branches of the tree. However, many roots extend beyond the longest branches, sometimes a distance equal to two or more times the height of the tree. This is particularly true where soil volume is inadequate or compacted and adventitious roots have sought out more favorable soil medium, such as adjacent undeveloped property.

SOIL EROSION

Erosion rates from natural areas are typically less than 1 ton/acre/year while erosion from construction sites ranges from 7.2 to 1000 tons/acre/year (US EPA). It takes 500 years to create one inch of topsoil. (USDA & NRCS).

Unfortunately, space for construction on most urban sites is limited and this RPZ rule must be bent. Just how close an activity can come without seriously threatening the tree's survival depends on the species, the extent of proposed work, and the tree's health. A rule of thumb is not to disturb more than 25 percent of the roots within the drip line for any tree and allow extra space for sensitive trees. Refer to tree protection details at the end of this chapter.

Earthmoving within the RPZ usually kills a tree over time. Soil additions compact the soil around a tree and disrupt the normal balance between air and roots within the top layer of soil. This need for oxygen explains why a majority of tree roots are located in the top 12 to 18 inches of soil. Lowering the grade within the RPZ removes vital feeder roots, eliminates nutrient-rich topsoil and may lower the water table. Damage caused by cutting shallow roots within the top 12 inches will compromise a tree's vitality and expose it to disease. Damage caused by deeper excavation for foundations or utilities will sever structural roots and compromise the tree's stability.

One of the most common sources of damage to street trees occurs during curb and sidewalk replacement. Curb excavation severs structural roots along 180° of the RPZ, and sidewalk excavation can damage the feeder roots within the other 180°. During storms or high winds, these trees become hazards to life and property.

Tree saving practices during construction can be both time consuming and expensive. Make sure the tree or vegetated area is worth saving; i.e. the species should be desirable, in good health and have a projected life expectancy of at least 20 years. When the design intent is to save some trees while removing others, it is important to realize that tree masses form a community that protects individual species from windthrow and sunlight. Sudden increases in the amount of wind or sun may shock remaining trees and result in scorched leaves, broken branches, and worst – uprooted trees.

Conspicuous symptoms of construction damage may take years to appear. Tree decline from soil compaction may take two to seven years to appear as obvious symptoms of distress. Wilted or scorched leaves and drooping branches are the first signs of construction damage. In deciduous plants these symptoms may be followed by early fall coloring and premature leaf drop. Damaged conifers will drop excessive amounts of inner needles. Later on, there will be increasing signs including flowering out of season, excessive water sprout formation, and abnormal winter dieback.



Example of inadequate tree protection



Example of severed structural roots

Four people were killed and six seriously injured by a fallen tree in Queens whose roots had been severed by unauthorized sidewalk repair. (1997)

SELECTING TREES

TOLERANT TREE SPECIES

For both root severance and compaction: Ash, Red Maple, Sycamore
For root severance: White Pine, Eastern Red Cedar, Honey Locust, American Linden
For soil compaction: Catalpa, Eastern Cottonwood, White Poplar, River Birch

SENSITIVE TREE SPECIES

For both root severance and compaction: White/Paper Birch, Kentucky Coffee Tree, Hawthorn, Ironwood, Oaks
For root severance: Butternut, Black Walnut, Hickory, Redbud, Spruce, Fir
For soil compaction: White Pine, Red Pine, Aspen, Cherry, Basswood, American Beech

Also refer to NYC Department of Parks and Recreation *Tree Planting Standards*

CUT AND FILL

In theory, an earthwork strategy that balances cut and fill is preferred to hauling or importing soils, but this does not address the complexity of a well-layered soil profile. The greatest concern is that soil layers are disturbed and are never restored to their pre-construction state. Minimizing soil disturbance is the best strategy because it is very difficult to replicate the site's natural profile. Even industry standards do not address this. Earthwork specifications classify soil as suitable or unsuitable from the standpoint of bearing capacity, not on the basis of soil profile. Landscape specifications classify soil as either topsoil or clean fill.

From a resource-management perspective, a cut and fill balance can be achieved with careful planning. The challenge comes when a building requires a large amount of excavation for a basement or other large underground structure. In this instance there is likely to be excess soil that the designer may want to retain on site. The key considerations are:

- What kind of soil? What are the soil characteristics of the excess soil? Is the composition particularly susceptible to erosion as a result of its components? If so, what special measures need to be taken to ensure that it does not erode during or after construction?
- How can it be accommodated? Based on the soil composition, how steep a landform can be created that will result in a stable slope? Is the slope gradient capable of being suitably compacted and stabilized using either structural or vegetative measures or a combination of the two? If the soil is subject to erosion, are retaining walls a better alternative to reduce the gradient?
- How will it look? Will earth forms such as berms or benches look out of place in relationship to the surrounding context? What is the visual impact of the proposed earthwork on the site and adjacent properties?
- How will it affect drainage? Does the proposed earthwork alter the natural drainage pattern? By law, the earthwork cannot increase the amount of overland runoff on to an adjacent property (from pre-existing condition) and cannot cross a property line adjacent to a public right-of-way. Sites that are adjacent to wetlands, streams or coastal zones are



Curb removed from one side protects existing trees

photo: Mathews Nielsen Landscape Architects



Tree damage from construction equipment at New York Hall of Science

photo: Mathews Nielsen Landscape Architects

regulated by NYS DEC and carry stringent restrictions regarding altering overland flow. Sites within a Special Natural Area District are regulated by the Zoning Resolution of the City of New York.

- What time of year? Can earthwork construction activity be properly timed to minimize exposure to adverse weather conditions?
- Will this infringe on protected areas? Can excess cut be accommodated without infringing upon areas of the site that would otherwise be protected from construction impacts?
- Are there contaminants? Is the soil contaminated? If so, at what level? What are the economic impacts of disposal versus on-site retention? What mitigation is required to retain these soils on site?

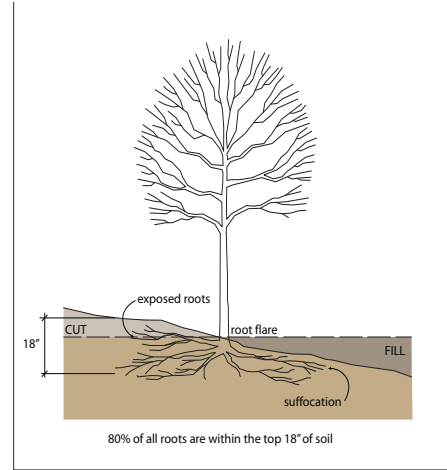

Cut and fill example

Based on the answers to these questions, the designer is more equipped to evaluate the relative advantages or disadvantages of retaining excess cut.

TECHNIQUES FOR MINIMIZING SITE DISTURBANCE

SUMMARY – KEY TECHNIQUES

See text for more detail.

TECHNIQUES	RESPONSIBLE PARTIES	RESOURCES
DESIGN PHASE		
Conduct Soil Analyses	Design team and DDC	specification
Plan for Tree and Vegetation Protection	Design team	detail
Plan for Erosion & Sedimentation Control	Design team - specs; Agency - permit	detail
Design – Grading, Drainage, Utilities	Design team	–
CONSTRUCTION PHASE		
Prevent Compaction	Contractor, guided by specs	detail/spec
Remediate Compacted Soil	Contractor, guided by specs	spec
Protect Trees and Vegetation	Contractor, guided by specs	details
Prevent Construction Soil Contamination	Contractor	details
Enforce Compliance	DDC and construction manager	–

DESIGN PHASE TECHNIQUES

CONDUCT SOIL ANALYSIS

Soil tests are the basis for sound planning and design decisions, as well as understanding the cost implications of the following: a) Protection and re-vegetation of the landscape; b) Remediating compacted soils; c) Predicting susceptibility to erosion; and d) Stormwater management strategies (see chapter: Water Management on Urban Sites)

Soil testing should be required by DDC in the initial project scope, and conducted by the design team at the beginning of the design process. Soil testing is neither complicated nor expensive. Samples are taken by hand with a soil testing auger and sent to a lab for analysis. Some landscape architects and civil engineers do their own collection and send it to the lab; others will subcontract this. The number and locations typically are identified by the landscape architect or civil engineer – each site location where vegetation and/or water management features are planned. These are project and site-specific, and to some extent borough-specific. Some areas, e.g. Staten Island, have more variety in soil types, and some sites have more history of disturbance.

NEW YORK CITY GEOLOGY

Crystalline Rock Formations: Manhattan, Bronx, & parts of Staten Island.
Coastal Plain Sediments: Parts of Brooklyn, Queens & Staten Island.
Glacial Till: Parts of Brooklyn, Queens & Staten Island.

Benefits of conducting soil tests early in the project include the following:

- Identify fragile soils; let the team set limits on heavy equipment use, reducing soil disturbance;
- Identify risk of slope failure, erosion and siltation, and protect water bodies from sediment.
- Minimize the environmental impact and costs associated with transporting and introducing imported topsoil or fill;
- Aid in determining landscape and stormwater management design strategies and budgets early in the design process;
- Predict costs associated with on-site soil remediation, soil amendments, soil importation and excavation;
- Aid in determining appropriate plant palette for re-vegetation;
- Reduce the long-term need for fertilizers and maintenance.

TEST THE SOIL

The following tests are recommended for every site and every project with open space. These tests are performed to determine nutrient levels, soil reaction, biologic composition and possible contaminants. Soil samples should be evaluated by a qualified geotechnical engineer or soils scientist licensed in the State of New York. Tests should include the following:

Chemical and Biological Tests: This testing determines the soil classification (% of soil, silt, clay), the susceptibility to erosion and the nutrient levels. Understanding the soil classification and composition allows the designer to choose an appropriate plant palette and decide if the soils need to be amended for plants to thrive (See Maximizing Vegetation chapter for a discussion of amended soils).

Understanding erosion potential helps to guide site design and planning. Soils that exhibit a **low** susceptibility to erosion are suitable for creating on-site berms, and also may be suitable as planting soil depending on other test results. Timing of earthwork should be coordinated with optimum planting seasons to establish a vegetated cover to avoid erosion and sedimentation. Soils that exhibit a **moderate** susceptibility to erosion may also be suitable for on-site reuse, but should be immediately covered with a bio-degradable erosion control blanket until such time as a vegetated cover becomes well established. Soils that exhibit a **high** susceptibility to erosion should, ideally, not be disturbed. They are likely to have a very poor bearing capacity and be being very poor candidates for water infiltration, for Best Management Practice measures, and cannot be amended for use as planting soils without significant cost.



Compacted soils result in poor drainage and reduced air movement

photo: Mathews Nielsen Landscape Architects

Drainage rate test: This is a field test to ascertain the rates of infiltration and percolation of clean water that will permeate the soil under saturated conditions. The results will show how compacted the soil is, and its bulk density (compaction and organic content). Together with the chemical and biological tests, the results allow the team to choose plants, and decide which storm water management strategies will be effective. For example, if the drainage rate is slow, plants that are tolerant of both wet and dry must be selected. Drainage testing should be required again at the end of construction, before topsoil is added or planting begun. This will determine if conditions have worsened due to construction disturbance, if corrective action is necessary, and will settle disagreements about responsibility.

Contamination tests: Typically DDC requires testing for heavy metal contamination based on a property's history of occupancy and the related likelihood of contamination. We recommend that all urban sites be tested because of the generally higher level of past industrial uses in NYC, and especially for those uses where contact with the soil is expected, such as daycare centers, outdoor museum-related areas etc. Evidence of contamination would require coordination with the NYS Department of Environmental Conservation and, possibly mitigation measures. Testing would look for molybdenum, aluminum, boron, lead, selenium, mercury, chromium, cadmium and PCB's, petroleum distillates and hydrocarbons in accordance with the testing methods of NYS DEC.

TESTING PROTOCOLS

Chemical tests. Examine particle size analysis compared to USDA Soil Classification System per ASTM D422 (hydrometer test) or ASTM F1632 (pipette test). Silt and clay content to be determined on soil passing #270 sieve. Test for hydraulic conductivity per ASTM F1815. Determine amounts of nitrate, ammonium, nitrite, phosphorous, potassium, calcium, magnesium, iron, manganese, zinc, copper, soluble salts, cation exchange capacity and pH. Tests for erosion prevention should include a Pinhole dispersion test, a Crumb test and US Soil Conservation Service dispersion test

Biological tests: Obtain active bacterial biomass, total bacterial biomass, active fungal biomass, total fungal biomass, protozoa content, nematode count and hyphal diameter. Identify organic content by Ash Burn Test or Walkley/Black Test per ASTM F1647.

Tests that fall within the following ranges are suitable for in situ use for topsoil and vegetation areas without amendment:

- Soil: Sandy loam per USDA classification, ASTM D 422 or ASTM F 1632.
- Organic content: 3% minimum.
- Hydraulic conductivity: no less than 3 inches per hour.
- PH: 5.5 – 6.5 +/- 0.5
- Soluble salt content: 0.08-0.50 mmhos/cm (dS/m).
- Carbon nitrogen ratio: 10:1 to 25:1

Drainage tests: Test for soil drainage rate using the hydrometer test or combined hydrometer and wetsieving method in accordance with ASTM D 422.

Percolation test: The depth of the test hole will be based on pre or post construction site condition and what information is desired. In general, the depth of the test hole(s) is placed within the "slowest" portion of the soil horizon (i.e. the layer most likely to be compacted). Soil must be saturated 24 hours before percolation test is performed. Soils exhibiting a rate of 5 minutes per inch of drop (mpi) are considered extremely permeable; soils with a rate of 60 minutes per inch of drop (mpi) are considered compacted.

Infiltration test: Tests should be done when the soil is at field capacity or between 12 to 48 hours following a saturating rain. Rapidly draining (permeable) soils will absorb between 6 to 20 inches per hour; moderately well draining soils will absorb between 2 to ½ inch per hour; slow to impermeable soils will absorb .2 or less inches per hour.

PLAN FOR TREE AND VEGETATION PROTECTION

During planning and design, the team should follow the steps below and include the results in the construction documents.

1. Inventory site vegetation before beginning site planning/design. Clearly mark significant trees and vegetated areas to be retained, and resurvey if not clearly demarcated;
2. Engage the services of a NYS certified arborist to assist with evaluation of viable plant material and consult on mitigating measures to protect mature trees;
3. Prepare a site protection plan showing the sizes and areas of vegetation to be removed, transplanted, or protected. Limit areas where contractor may stage equipment so that they do not impact protected trees and vegetation;
4. Coordinate architectural, engineering and landscape strategies early in the process. Key decisions include setting the finished floor elevation, and establishing the pathways for site utilities;
5. In the design and documents, show tree protection extending at least the full perimeter of the tree canopy (“drip line”), and preferably one radial foot for every inch of caliper for tolerant trees and 1.5 radial feet for every inch of caliper for sensitive trees. For example, a 12 inch caliper tree would require a 24 foot diameter tree protection fence for tolerant trees and 36 feet diameter for sensitive trees;
6. Delineate areas for topsoil stripping and locate topsoil stockpile areas; specify protective covering for stockpiles and secure from wind;
7. Consider structural designs where there are tree roots, such as grade beams and piles or piers.

PLAN FOR EROSION AND SEDIMENT CONTROL

The US EPA has found that runoff from developed sites typically carries soil and sediments, road salts, nutrients and pesticides, fluids from motor vehicles and toxic chemicals in amounts damaging to natural resources. Generally, damage to resources from development is directly proportional to the amount of impervious surface on the developed site. Studies show that water resources are damaged whenever impervious surface area within a watershed exceeds 25 to 30 percent and degradation can be detected with as little as 10 percent impervious surface.²

The importance of controlling stormwater, and keeping it from polluting our waterways, has led to legislation requiring permits and plans to be filed before construction projects can proceed.

Construction activity on publicly controlled sites is currently regulated by NYS DEC. Major goals are to control runoff and windblown dust and to maintain the flow rate and amount of water at preconstruction levels.

It is a design team’s responsibility to plan for erosion and sedimentation control, and include the requirements in the construction documents. For NYC sites over one acre, the regulations require the preparation of a plan (drawing and text) called a Stormwater Pollution Prevention Plan (SWPPP). This must be prepared by a licensed landscape architect or professional engineer to receive certification. For smaller sites, there is no formal submission requirement. The SPDES General Permit for Stormwater Discharge from Construction Activity requires covered projects to comply with NYS water quality regulations. See the Laws and Regulations section for an outline and references.



Good site protection at Riverdale Country School

Photo: Mathews Nielsen Landscape Architects

² www.epa.gov/nps/MMGI/Chapter4/ch4-3a.html www.epa.gov/nps/MMGI/Chapter4/ch4-3a.html

Structural stormwater controls are both preventative and mitigative because they control erosion and sediment movement. Examples include sediment basins and traps, silt fences and the mulching/ seeding of exposed areas. Non-structural controls decrease the erosion potential. A non-structural approach designs within the natural constraints of the site, and minimizes the area of exposed soil and stabilizes cut and fill. Erosion controls have distinct advantages over structural sediment controls, by reducing the amount of sediment transported off-site, thereby reducing the need for sediment controls.

For techniques to control stormwater pollutants and to prevent erosion and sedimentation using non-structural methods, refer to the chapter: Water Management on Urban Sites.

Effective September 2004, New York State Department of Environmental Conservation published “Stormwater Management Guidance Manual for Local Officials” to help regulated municipalities and publicly-owned institutions develop and implement local control of Construction Site and Post-Construction stormwater runoff as required under state and federal law (US EPA Phase II stormwater regulations). This document clarifies municipalities’ obligations under the 1990 US EPA Phase I rules and 1999 Phase II rules.

DESIGN FOR GRADING, DRAINAGE, UTILITIES

Grade Modification: One of the “defining moments” in site design is setting the finished floor elevation of a building. This frequently determines the amount of topographic modification that will be required to the building perimeter, and often, adjacent parking areas, plazas and walkways. Grade modifications around trees should be avoided where possible. If modification to existing grade within the protected root zone (RPZ) of a tree is absolutely necessary, porous fills such as sand or aggregate may be used to a depth of 12 inches for trees considered tolerant. Tolerant species can withstand up to 6 inches of high quality, organically rich loam. If lowering the grade or excavation is required within the RPZ, only hand digging should be permitted. If excavation for utilities or foundations is required within the RPZ, use air spading or tunneling when roots over one inch diameter are encountered. For all digging operations, require that exposed roots be cut cleanly to promote quick wound closure and regeneration. Vibratory plows, chain trenchers, and hand tools are less likely to rip roots than bulldozers and backhoes. Minimize damage by avoiding excavation during hot, dry weather; keeping the plants well watered before and after digging; and covering exposed roots with soil, mulch or damp burlap as soon as possible. Use retaining walls to protect vegetated areas when regarding. Tree wells are not recommended as their radius rarely accommodates the extent of the root system and their installation will likely cut roots around the entire perimeter of the RPZ.



photo: Mathews Nielsen Landscape Architects

Erosion control fabric and vegetated slope protection at Riverdale Country School

Drainage Modification: Alteration to existing topography can alter the amount of water to which a single tree or vegetated area has been accustomed. Conducting pre- and post-runoff calculations is required for approval and permitting (see above) and is particularly critical when the project intends to avoid automatic irrigation or when the project abuts a sensitive ecosystem, particularly a waterbody of any kind. To the greatest extent possible, the project’s overall site drainage strategy should preserve pre-existing overland flow patterns. On larger sites, the designer should also consider the existing drainage pattern beyond the immediate project limit. Techniques to retain, filter and utilize water collected on-site are discussed in the chapter: Water Management on Urban Sites.

Utility Coordination: Construction impact commonly occurs as a result of uncoordinated site utilities, and the designer/contractor’s assumption that utility drawings are merely “diagrams” or “schematic” layouts of utility runs. The typical drawing shows utility lines as the shortest distance between the service point of connection and its terminus within the new structure. From a project’s inception, consulting

engineers should be directed to avoid trees and sensitive vegetated zones, and to lay out utilities with oblique bends or curves as required to preclude vehicular encroachment and disturbance. It should be required professional practice to overlay all utility lines on the existing survey to verify that areas and trees designated for protection are truly free and clear of excavation. Excavation should be assumed at the worst case of sloped cut, as a contractor will charge extra for sheeting and shoring a narrow trench cut.

Trenchless Technology: Trenchless technology is an umbrella term that encompasses a total system of procedures and equipment as alternatives to open-cut excavation. Trenchless technology can be used for localized repair, replacement and new installation of utilities. In addition to saving cost and time, utility work using trenchless methods protects trees, vegetated areas and reduces the likelihood of compaction in future planted areas.

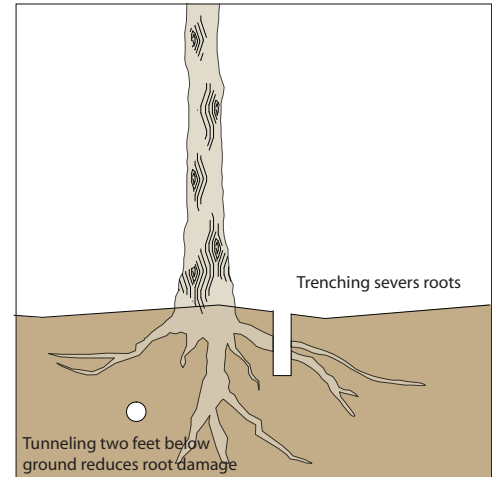

Microtunneling is an example of a trenchless technology

CONSTRUCTION PHASE TECHNIQUES

While the contractor must carry out these construction phase techniques, the design team first must require them in the documents, either designed specifically or required with a performance specification – and enforcement by the construction manager is critical. Tight urban sites make protections more difficult, and, historically, site disturbance has had a lower priority than efficiency and cost. While some of these techniques seem to apply to larger, non-urban, sites, they are even more important for small sites, where there may be only a strip of open space and the temptation to use it for staging even stronger.

STOCKPILE TOPSOIL

Topsoil is a valuable site resource and cannot be truly replicated, because it has been formed over millennia and is specific to its location. Topsoil is essential to establish new vegetation and the site's topsoil should be stockpiled, protected and then reapplied to the new landscaped areas. Typically, topsoil is stripped to a depth of six inches after the site is cleared of unwanted vegetation. Topsoil stockpile(s) should not exceed 6 feet high - otherwise the soil will become compacted under its own weight. The pile(s) must be covered with tarpaulins and be surrounded by runoff diversions to protect them from pollutants. Prior to reapplication, the topsoil should be tested to determine if amendments are necessary.

PREVENT COMPACTION

Haul Roads: A properly located and constructed haul road is cost efficient and will have less adverse impact. Restrict traffic in sensitive or compaction-prone areas, and restrict all equipment to specific tracks or traffic lanes through the construction site. Haul road lanes should be pre-prepared using a geotextile fabric and 12 inches of gravel overburden to minimize compaction penetration, discourage rutting, and facilitate removal after construction. Minimize the width of the road surface, typically 12 feet wide for straight segments and 16 feet for curves. In areas of particularly sensitive soils, wood or metal platform sections, known as skid trails, can be used. See detail of construction access road at the end of the chapter.

Equipment Impact: Low ground pressure equipment or flotation tires reduce pressure exerted by heavy equipment, thereby reducing compaction. Equipment such as backhoes, excavators, and bulldozers come fitted with rubber tracks or high flotation tires that apply between 1.5 to 3.15 pounds per square inch ground pressure instead of conventional machinery that applies 12 to 14 psi per tire.

REMEDiate COMPACTED SOIL

Subsoiling: Subsoiling is a technique that uses mechanical means to “rip” the soil within a compacted zone. Agricultural equipment such as a deep rip or tine machine is effective in fracturing and heaving the soil to break up compacted zones. The ripping operation should be carried out to 1.5 times the depth of the bottom of the compaction zone. Subsoiling operations must be done when the soil is dry. This is not always effective alone, because it cannot restore other good-soil properties that may have been lost to poor construction practices.

Adding Organic Matter: Another technique is to add organic matter to improve soil structure and thereby improve its water-holding capacity and resistance to erosion. The best types of organic matter for this application are composted animal manures, crop residues, municipal yard waste, and biosolids. These organic materials should be spread at a rate of 1-3 inches of depth and worked into the top 6 inches of soil. This operation is most effectively done in the autumn to allow decomposition through the fall and winter. Routine applications of organic matter maintains good soil structure, helps retain moisture and introduces nutrients for plants. A single, large application of organic matter is not effective because it decomposes and requires annual replenishment. Under no circumstances should peat moss or Class B biosolids be used. Peat moss is a non-renewable resource and Class B sewage sludge may contain unacceptable levels of pathogens, salts and heavy metals. For more information on improving the organic content of soils, refer to the Amending Soils section of the chapter: Maximize Vegetation.



photo: Mathews Nielsen Landscape Architects

Example of haul road and contractor parking area using gravel over geotextile fabric

Mulch: is a material applied to the soil surface for the purposes of retaining soil moisture and suppressing weeds. Mulch, if properly specified, can also introduce organic matter through decomposition. Satisfactory mulches for this purpose include bark, hay or straw, paper pulp, peanut or cocoa hulls and similar agricultural residue. Such mulches must be specified as aged at least 6 months; otherwise the initial decomposition process can alter the micronutrient balance in the soil. Mulch should be applied to a depth of 2-3 inches. It must not be piled up against tree trunks as this will encourage bark rot. Mulches require annual reapplication to remain effective.

Air Spading: An air spade is a tool to remove and break up soil using compressed air. The technique uses a focused air stream to cut through soil quickly and with great accuracy, minimizing damage to tree roots, and not harming existing subsurface utility bedding. Once the soil has been removed, new utility runs may be installed and the affected area backfilled with friable (uncompacted) topsoil. Air spading is also a technique used by arborists to reveal causes of declining tree health.



photo: NYC Dept. Parks and Recreation

Air spading

PROTECT TREES AND VEGETATION

Protecting vegetative cover is the single most effective strategy to prevent erosion. Protected zones thus remain un-compacted and this greatly increases the chance for plants to survive construction. Protections should include the following:

- Define the construction access route/area, crane location(s), stockpile and staging areas, and parking areas. Restrict on-site parking if protected areas will be impacted. Plan for modifications to the accessible areas as work progresses to minimize the duration of impacts, particularly during sensitive times of the year (wet weather, growing seasons);
- Prepare trees that will be impacted by watering, adding compensatory fertilization and pruning (Refer NYC DPR specifications);



photo: Mathews Nielsen Landscape Architects

Dying tree as a result of site disturbance

- Do not allow vehicles or materials to be stored within the tree protection zone;
- Construct tree protection fences of durable and highly visible materials, and at least 3 feet high to discourage stockpiling;
- Install temporary wheel stops at protected vegetated areas, and block unauthorized vehicle access with physical barriers. Clearly mark any on-site construction parking zones;
- Do not use bulldozers to remove trees; this will result in breaking limbs of trees to remain and compaction of root zones; trees should be felled by incremental topping, using ropes to lower limbs to the ground;
- Carefully excavate for topsoil stripping to avoid contamination with subsoil;
- Protect topsoil stockpiles with erosion control fabric to prevent wind erosion and contamination from construction activities;
- Ensure that protected vegetated areas are watered during times of low rainfall;
- Consult a professional arborist (ISA certified) during tree transplanting and excavation if structural or feeder roots are encountered. Refer to the techniques on air spading and trenchless technologies in this chapter.



photo: Mathews Nielsen Landscape Architects

Example of inadequate tree protection

Post Construction: After construction is complete, inspect the saved vegetation. Trees will not recover from construction damage for one or two years. Regular watering, mulching, pruning, fertilization and pest/disease control measures will likely be required.

PREVENT SOIL CONTAMINATION DURING CONSTRUCTION

Improper handling or disposal of materials used during construction can contaminate soil and harm retained vegetation. Chemical spills, chromium, acid washes, and alkalinity are some examples of typical pollutants that will penetrate on-site soils, runoff into sewers, and pollute water bodies. Improperly disposed-of solids can clog storm drain pipes and cause flooding.

Concrete washouts are prefabricated or site-constructed structures used to contain concrete and liquids when chutes of concrete mixers or pumps are rinsed out after delivery. The washout facilities consolidate solids for easier disposal and prevent runoff of liquids. Prefabricated concrete washout containers are delivered to the site, and some companies offer maintenance and disposal services. Site-fabricated concrete washouts should be sized to handle solids, wash water, and rainfall to prevent overflow. A 10-cubic yard concrete truck typically uses 7 gallons of wash water and a concrete pump truck uses 50 gallons.

PHASE CONSTRUCTION TO LIMIT SOIL EXPOSURE

Land-disturbing activities and erosion and sediment control practices should be performed in accordance with a planned schedule to reduce site erosion and off-site sedimentation. Construction scheduling should facilitate installation of erosion and sediment control measures prior to construction start, and break soil-disturbing activities into phases to coordinate with construction activities moving around the site. Grading activities should be limited to the phase/area that is immediately under construction to decrease soil exposure and its potential for erosion and sedimentation. Subsequent phases should begin only when the previous phase is nearing completion and its exposed soil has been stabilized.

STABILIZE EXPOSED SOILS

Exposed soils should be stabilized within two weeks of the onset of exposure. Ideally, permanent vegetation should follow each phase of construction; if this is not possible due to seasonal limitations, then mulch, seeding, or other measures of soil coverage can be used. Geotextile fabrics offer effective temporary or

photo: Mathews Nielsen Landscape Architects



Hydroseeding is a popular technique for applying seeds, fertilizer, and soil stabilizers in a single application

photo: Texas Commission of Environmental Quality



Example of compost filter berm to prevent downstream contamination

GROUND COVER AND RUN-OFF

Perennial vegetative cover from seeding has been shown to remove between 50 and 100 percent of total suspended solids from stormwater runoff, with an average removal of 90 percent. US EPA, 1993.

permanent solutions to erosion and the establishment of permanent vegetation. They aid in plant growth by holding seeds and topsoil in place. Some geotextiles are made of biodegradable materials such as mulch matting and netting. Mulch mattings are jute or other wood fibers that have been formed into sheets, and are more stable than normal mulch. Netting can be used to hold the mulch and mats to the ground but cannot be used alone to stabilize soils. Non-degradable geotextiles are used to line swales or temporary runoff-diversion channels where moving water is likely to wash out either temporary or permanent new plants. Geotextiles are the best solution when disturbed soils will be exposed for less than six months or where slopes exceed 30%.

Seeding is used to control runoff and erosion on disturbed areas by establishing annual or perennial vegetative cover from seed. This practice is economical, adaptable to different site conditions, and allows selection of a variety of plant materials. Temporary seeding with annual grass is appropriate in locations where earthwork is not complete but will not reoccur for 6 months or more, and when seeds can be sown in the spring or fall. Depending on the size and slope of the disturbed area, hydroseeding may be more cost effective than hand seeding. Annual rye grass is the recommended temporary seed cover type for NYC's climate. Annual rye grass germinates within 7-10 days and provides reliable soil retention within three weeks.

Compost blankets are a recent technique that has proven effective in erosion control. A compost blanket is a layer of loosely applied compost that typically incorporates seed. It is applied to a depth of 2-3 inches either by hand or by machine. On slopes greater than 2:1, netting should be used in conjunction with the blanket. The cost of a compost blanket is comparable to straw mat and less expensive than a geotextile blanket.

Permanent vegetative cover requires more care in soil preparation, finished grading, and maintenance and should be part of the site's overall landscape design.

INSTALL PERIMETER STORMWATER RUNOFF CONTROLS

To control stormwater runoff, silt fences should be properly installed around the perimeter of the construction site. (See detail of a silt fence at the end of the chapter) Catch basin inlets receiving stormwater flows from the construction site must be protected with adequate inlet controls. Sediment basins should be created where space is available.

A recent innovative technique is a compost filter berm, which can be used in place of a traditional silt fence. This is a dike of compost that is placed perpendicular to runoff to control erosion and retain sediment. The berms are placed along the perimeter of the site, or at intervals along a slope. These are particularly appropriate on sites with small drainage areas. The compost filter berm is trapezoidal in cross-section and provides a three-dimensional filter that retains sediment and other pollutants while allowing cleaned water to flow through the berm. Composts used in filter berms are made from a variety of feedstocks, municipal yard trimmings, municipal solid waste, biosolids, and manure. Compost quality must comply with NYS DEC regulations.³

DDC ENFORCEMENT

DESIGN PHASE ENFORCEMENT

NYS DEC requires, as part of the General Permit for Construction Activity, that municipalities have plan reviewers whose responsibility it is to ensure compliance with the Stormwater Management and Erosion and Sediment Control. DDC is responsible for reviewing erosion and sedimentation control plans for compliance with State laws and regulations.

To comply with Local Law 86, effective January 1, 2007, all City-funded capital projects with a construction cost of \$2 million or more (including new construction, additions and substantial renovations) must be designed in accordance with the US Green Building Council's LEED green building certification program, achieving a LEED silver rating or higher. Requirements for submittals for certification are listed in the LEED Version applicable to the project.

DDC will require that a Site Protection Plan be part of the required drawings for consultants. This document will be subject to review and approval by DDC's Landscape Division. The plan (SP-1) should be a composite plan that illustrates all at-grade or subsurface work required to construct the project. The plan must show:

SP-1 Drawing Requirements:

- Building footprint and all hardscape including parking, drives, walkways, plazas, and streetscape improvements;
- All new utilities and associated above or below-grade appurtenances (RPZ's, detention tanks, etc);
- Proposed landscape improvements and their relationship (if any) to existing natural features to remain;
- Extent of earthwork required to establish new grades and to excavate for new subsurface improvements. Note whether excavation will be sheeted/shored or open cut; (assume open cut up to 4 foot depth; shoring for deeper excavation per OSHA).

In addition, the consultant is required to customize standard site protection specifications to ensure that current best management practices and materials are utilized.

CONSTRUCTION PHASE ENFORCEMENT

NYS DEC requires, also as part of the General Permit for Construction Activity, that sites are regularly inspected during and after construction. NYS DEC recommends that the applicant maintain the facilities and treatment and control systems by removing sediment from sediment traps or sediment ponds when their capacity has been reduced by 50%. NYS DEC further recommends that the applicant or its representative be on site at all times when grading activity takes place, and document the effectiveness of all erosion and sediment control procedures. Weekly reports are required to be submitted to DDC's resident engineer or construction manager.

SP-2 Drawing Requirements:

- Construction access route, staging area for trailers, materials and on-site parking and crane/hoist (if applicable);
- Stockpile area for topsoil and fill (2 different piles based on approximate anticipated quantities) and vehicle access to the piles;
- Area(s) to be protected and individual trees to be protected;
- Details of a construction access/haul road, individual or mass tree protection, silt fences, hay bales and other erosion and sediment controls.

Any deviations from the SP-1 drawing must be brought to the attention of the DDC Construction Project Manager, Construction Manager and Design Consultant at the project kick-off meeting and a procedure for resolving conflicts must be developed before the contractor may have access to the site.

COMPLIANCE

Under current NYC policies, there are several methods by which site protection are enforced, using financial penalties. NYC DPR requires restitution for trees removed or damaged by construction. The cost is calculated on the basis of the Basal Area Replacement Formula (BARF). The cost/replacement calculation is the area of the tree's trunk measured at breast height (dbh). For example, a 4 inch caliper tree may be either replaced with 2 three-inch caliper trees or by payment to DPR (currently \$1,500); a 12-inch caliper tree may either be replaced with 16 three-inch caliper trees or a payment (currently \$12,000). On Park property, significant fines can be imposed if a contractor damages trees or vegetation, under NYC Administrative Code 18-129.

It is typical for public construction projects to withhold 10% of a landscape contractor's bid price until the end of the warranty period. However this amount of money is rarely enough to ensure compliance with landscape restoration requirements, if problems occur.

DDC PROJECT MANAGERS' AND CMS' RESPONSIBILITIES

- Review and understand the Site Protection Plans (SP-1 and SP-2) prepared by the Design Consultant and Contractor
- Budget for costs associated with proper site protection
- Schedule project in accordance with proper site protection
- Discuss site protections at regularly-scheduled project meetings
- Identify potential conflicts between SP-1 and SP-2 plans
- Facilitate resolution of conflicts such that site protection is given maximum priority

RESOURCES

- “Urban Hydrology for Small Watersheds.” Technical Release 55, USDA, NRCS, 1986
- “Urban Soil Primer.” USDA, Natural Resources Conservation Service, 2005.
- “Wheel-induced soil physical limitations to Root Growth.” Voorhees, W. B., 1992
- New York State Stormwater Design Manual. NYS Department of Environmental Conservation, August 2004.
- New York State Standards and Specifications for Erosion and Sediment Control. NYS Department of Environmental Conservation, February 2005.
- Rules and Regulations for the Protection from Contamination, Degradation and Pollution of New York City Water Supply and its Sources. NYC Department of Environmental Protection. 2002.
- New York State Stormwater Management Design Manuals. NYS Department of Environmental Conservation www.dec.ny.gov/chemical/29072.html
- New York City Reconnaissance Soil Survey. United States Department of Agriculture and the Natural Resources Conservation Service, 2005.
http://www.nycswcd.net/soil_survey.cfm
- International Society of Arboriculture www.isa-arbor.com
- Arboricultural Specifications and Standards of Practice. Oak Park, Illinois, May 2003
- “Avoiding Tree Damage During Construction,” International Society of Arboriculture, December 2004
- “Construction Phase Plan Review”:
<http://cfpub.epa.gov/npdes/stormwater/menuofbmps/index.cfm>
- “Erosion and Sediment Control During Land Development”:
<http://www.act.gov.au/envirom>
- “Soil Compaction-Causes and Consequences”;
<http://www.extension.umn.edu/distribution/cropsystems/components.html>
- “Construction Site Management”:
<http://www.epa.gov/nps/MMGI/Chapter4/ch4-3a.html>
- Managing Soil Compaction
<http://www.ext.colostate.edu/PUBS/crops/00519.html>
- Santa Monica Green Building Program : Inventory, Mark & Protect Topsoil
<http://greenbuildings.santa-monica.org/construction/topsoiltree.htm>
- “Caring for the Land.” Bruce Hendler, 1977
<http://planning.org/APAStore/Search/Default.aspx?p=2261>

UNDERSTANDING SOILS

Soil is the interface between the earth's atmosphere and bedrock or ground water. It has either formed in place or has been transported to its present location by wind, water, ice, gravity, or humans. There are more than 22,000 different soils identified in the United States. Eighty-seven soil types have been identified in NYC thus far; as of 2005, soil mapping is based on sites of 40 acres or larger. While this information offers a general understanding of a project's geologic context, site specific soil tests are required. Designers can best predict how soils will react to different uses by understanding soil properties, such as soil texture and structure, particle-size distribution, soil reaction, and bulk density. This understanding enables projects to minimize maintenance costs, prevent harm to people and ecosystems, and be durable over time. Well structured soils sustain biological activity, diversity, and productivity, regulate water and solute flow, filter and immobilize noxious materials, and provide support for structures. Construction activities, compaction, and surface sealing dramatically change soil properties and can result in a reduced ability to perform the critical functions or activities of natural soil.

Urban soils can be divided into two types: natural soils, which formed in material naturally deposited, and anthropogenic soils, which formed by in human-deposited material or fill. New York City's complex geology includes layers of crystalline bedrock, sedimentary rock, coastal plain sediments, and glacial deposits, which are classified as natural material. Urban soil characteristics depend on the following: a) how deep the site excavation has been/will be; b) if imported fill was/will be mixed with original soil materials; and c) the properties of the original soil or prior uses of the site. Changing the order of the soil layers alters soil properties.

All soil is made up of mineral matter (clay, silt, sand), organic matter (living or dead organisms), air, and water. In the urban arena, it may also include manmade materials such as construction debris, dredge fill, coal ash, and municipal solid waste. Soils are made up of horizons or layers that result from soil-forming factors. In an undisturbed area, there are 6 major horizons that form the soil profile and include the uppermost layers of largely organic matter, subsoils (largely mineral matter) in the middle range, and bedrock at the lowest level. In nature, soils are altered by topography and microclimate as well as decomposition of organisms. Urban soils differ from natural soils because they have been altered to some degree through filling and construction. Construction typically disrupts the natural soil profile by removing topsoil or mixing topsoil with subsoils, importing foreign soils for fill or growing medium, altering natural drainage patterns, and creating compacted soil layers that can result in a perched water table. This is an impenetrable hard pan layer that prevents downward water movement and fills the root zone with too much water or prevents water from reaching plant roots. A perched water table can also be very damaging to surfaces as trapped, shallow water will freeze and heave pavements.

Physical soil properties: Sand, silt and clay are defined on the basis of the size of each individual soil particle' the composition of the three determines the soil texture. Soil texture affects water and air movement through the soil, as particles of different sizes pack together and thus determine the size and spacing of pores and channels. Soil structure is the combination of these primary soil particles into secondary units or aggregates. Organic materials and clay are important binding agents. When soil is dry, the pores are mainly filled with air; when soils are wet, the pores are mainly filled with water. A "textbook" soil is comprised of 45 percent mineral, 25 percent air, 25 percent water, and 5 percent organic matter. The mixture of particle sizes affects water, nutrient, and contaminant absorption. Sand particles have the largest pore spaces and allow water to drain most freely. Clay particles have very small pores, so they tend to absorb and hold more water.

Chemical soil properties: Soils supply air, water, nutrients and living space for micro-organisms,

plants, animals, and humans. The ability of soil particles to hold and release nutrients is called the cation-exchange capacity (CAC). Cations in the soil are positively charged nutrients such as nitrogen, sodium, calcium, and potassium as well as trace metals. Soil acidity, as measured by pH (scale 1-14), is the common measure of soil reaction. The lower the number, the greater the acidity. The midpoint of the pH scale is neutral (7.0), a good level for the growth of most plants. At higher pH levels (8.5+), metals are sequestered in the soil; at lower levels, metals are released and become available for ingestion by plants and animals. Most urban soils have a pH level higher than 7.0 due to the presence of alkaline waste materials (concrete, masonry, construction debris).

Biological soil properties: Soil organic matter is the thread that links chemical, physical and biological properties of soil. It is able to supply micronutrients to plants, to stabilize soil particles together as aggregates, to resist compaction, to promote water infiltration and to reduce negative environmental effects of pesticides, heavy metals and other pollutants by binding contaminants. Organic matter is comprised of decomposed animals and plants. In a healthy environment, the process is on-going, with new material continuously introduced and decomposed. In an urban environment, there may not be sufficient plant, insect, and microbial activity to replenish organic matter.

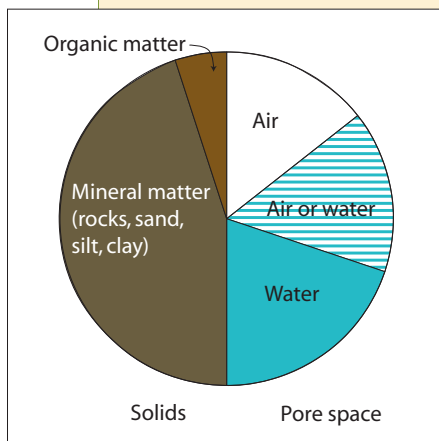

Water Movement: Water movement in urban soils includes infiltration, percolation and permeability. Infiltration rate is the velocity at which water can seep into the ground. A low infiltration rate is less than 6 inches per hour; a high infiltration rate is 2 inches per hour. Percolation is the movement of water downward and radially through subsurface soil layers to groundwater or a zone of saturation. This is also measured in inches per hour. Permeability describes the ease with which gases, liquids, or plant roots penetrate a bulk mass of soil. Soils are categorized by classes of permeability based on a vertical velocity profile ranging from very rapid to impermeable. The movement of water into and through soil depends on soil texture, soil structure, slope, bulk density, compaction, surface loading, and vegetation. In urban areas with large amounts of impervious or compacted surfaces, much of the water evaporates into the air or runs off into sewers and water bodies. As urban water runs off, it carries with it contaminants, sediments or soil particles that pollute the waterways.. Due to the urban heat island effect, water running off impervious surfaces introduces warm water into natural systems that alters the balance among microbial and aquatic habitats.

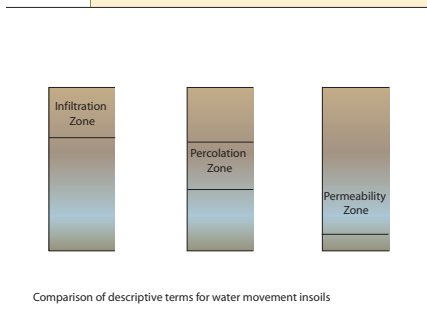

Bulk Density: Bulk density is the weight of soil solids per unit volume of soil. Bulk density is an important measure of compaction; a soil compacted by construction equipment will display a bulk density 150% greater than an open, friable soil. Bulk density is also a measure of organic content as organics are lighter than mineral content.

SAMPLE DETAILS

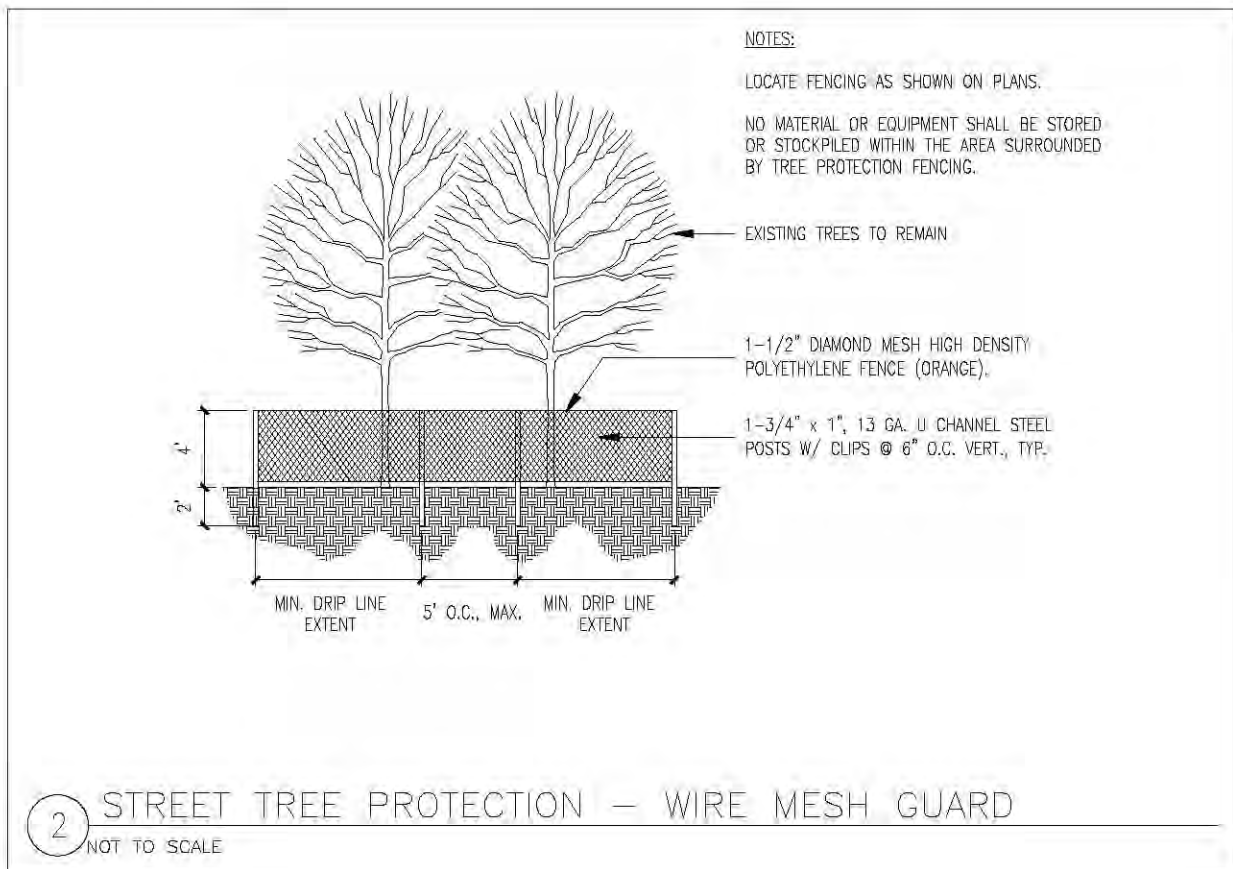
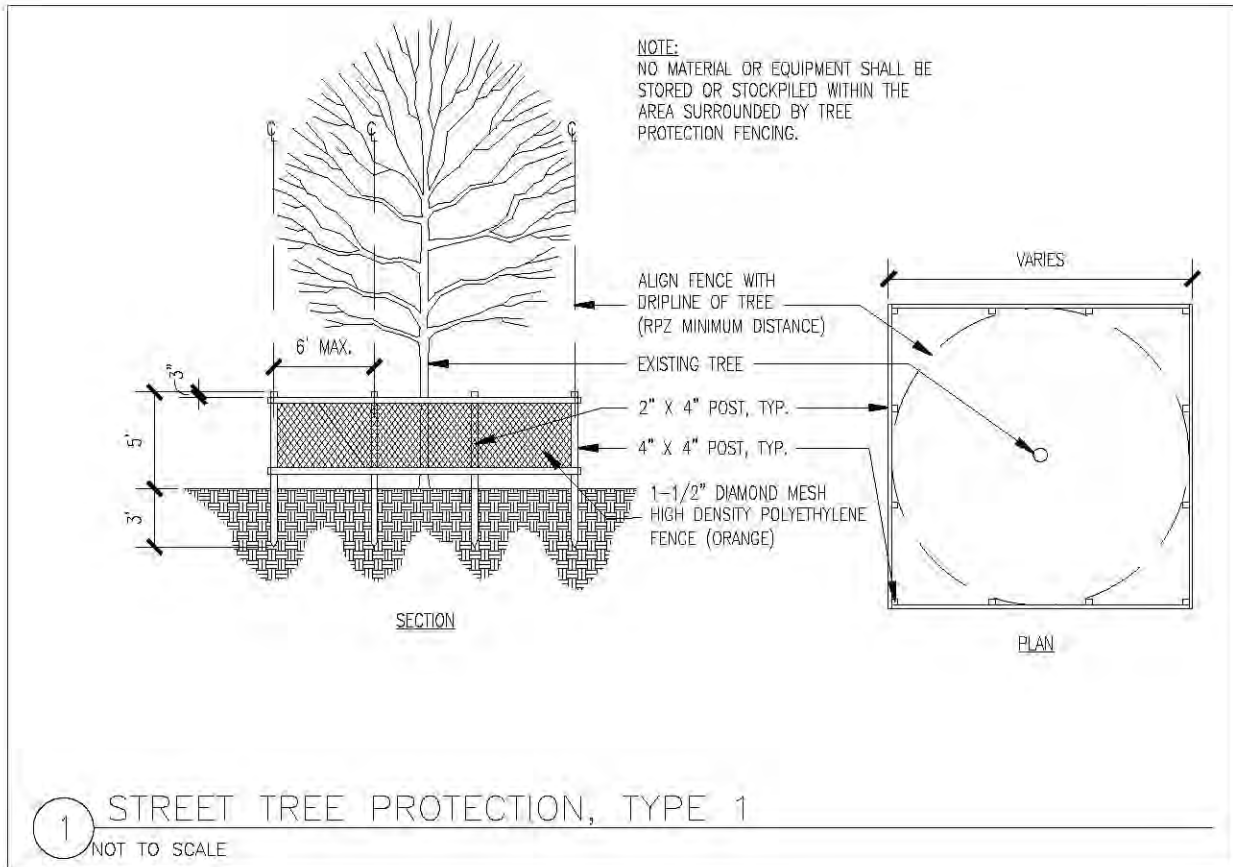

SAMPLE DETAILS

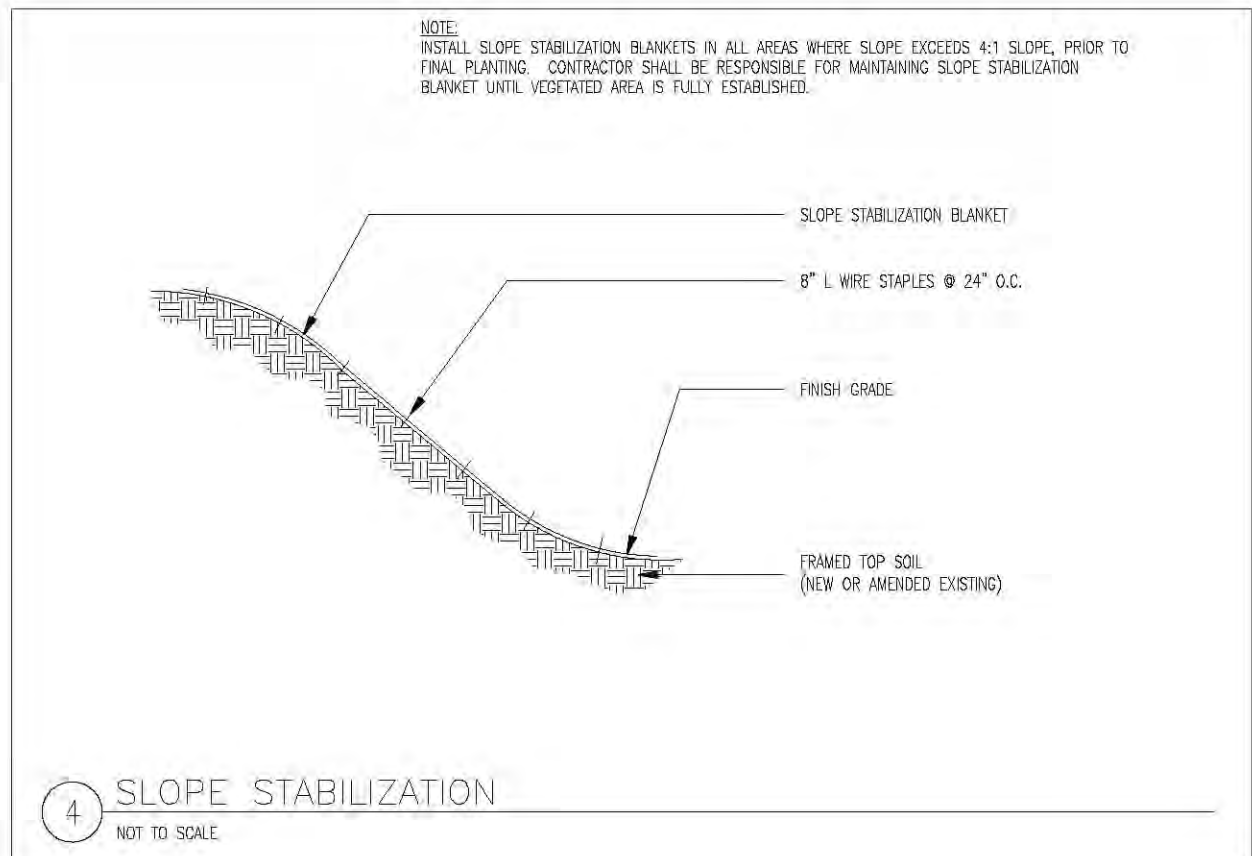
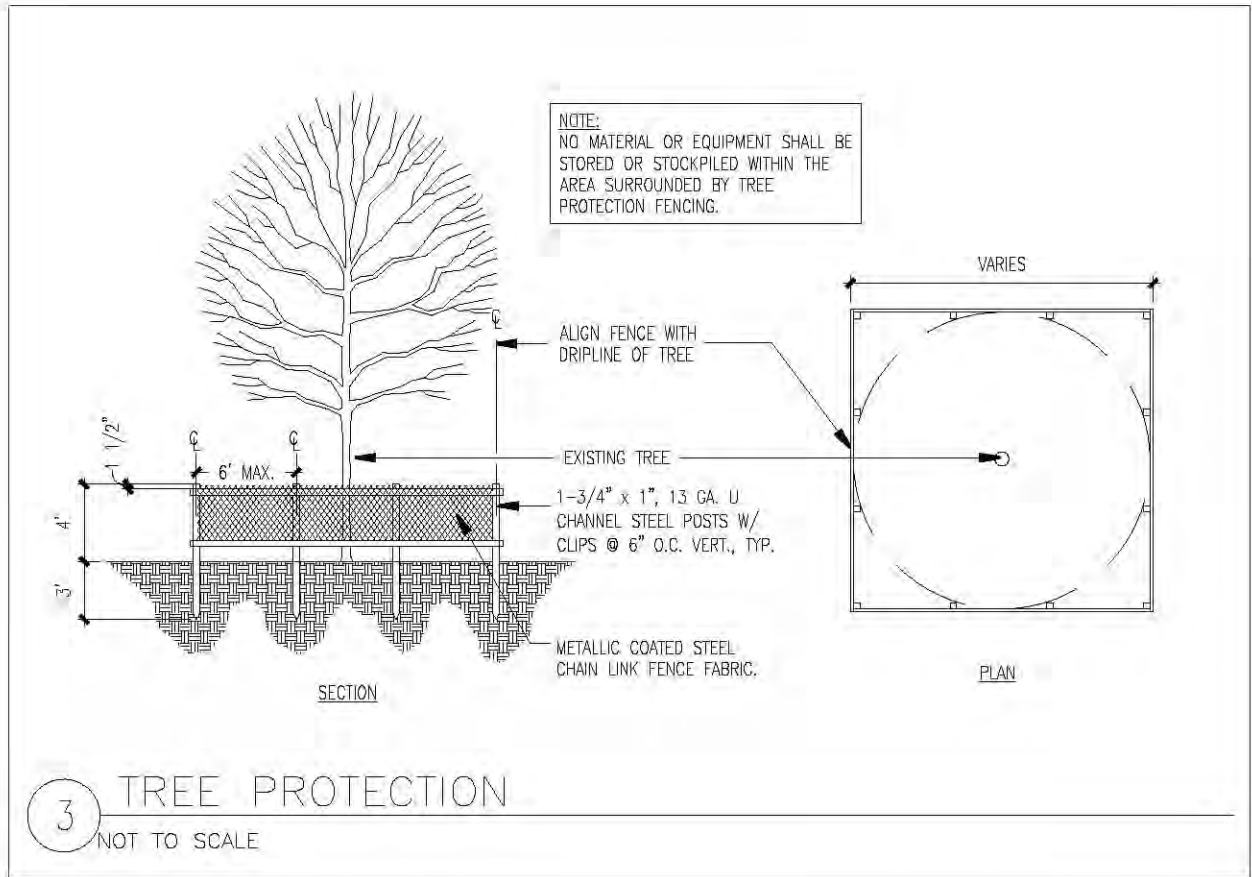

SAMPLE DETAILS

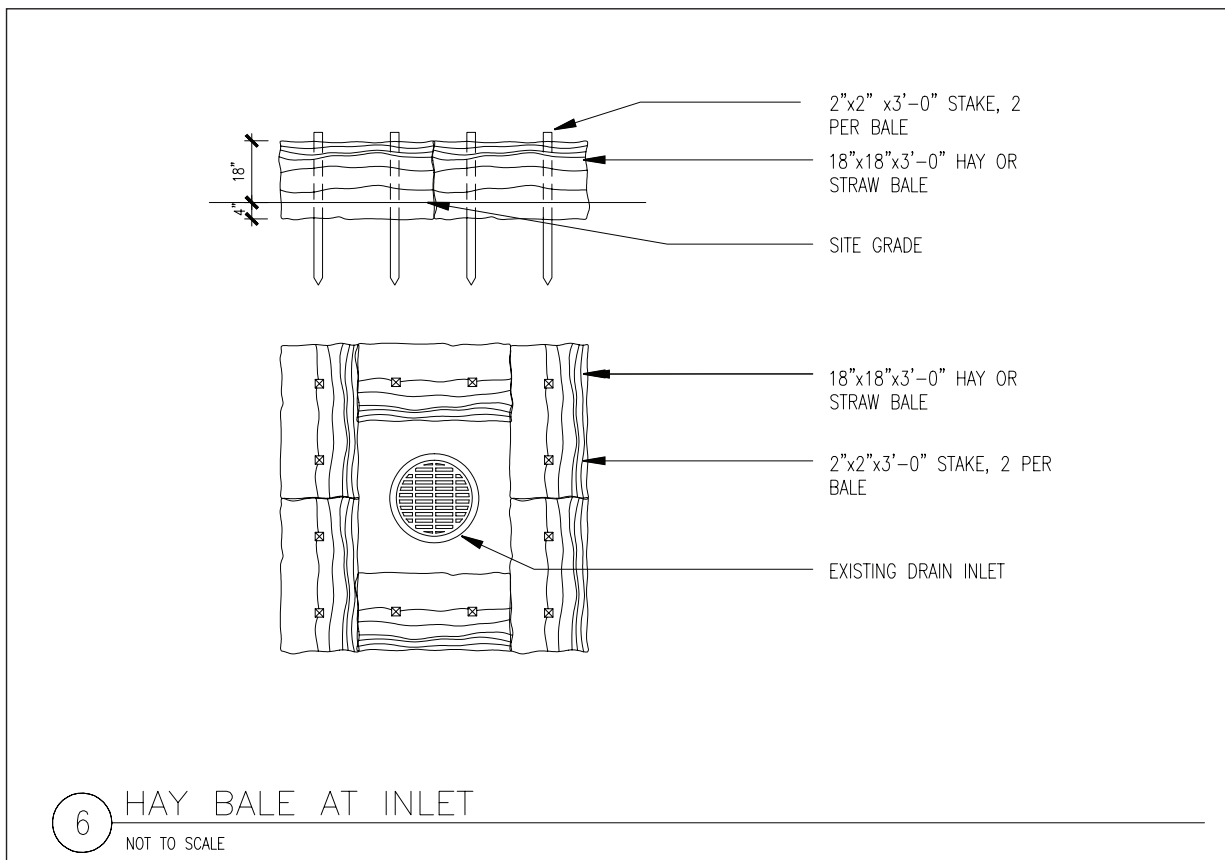
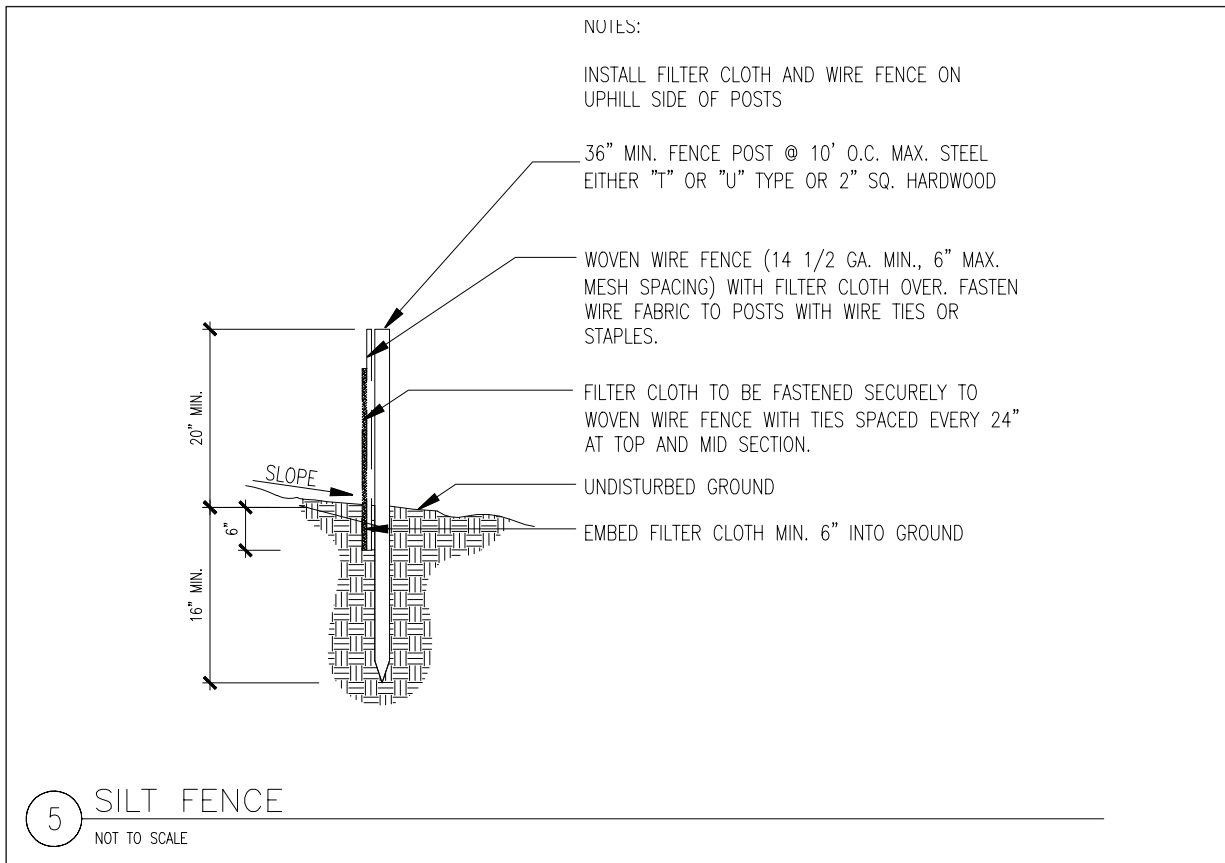

SAMPLE DETAILS

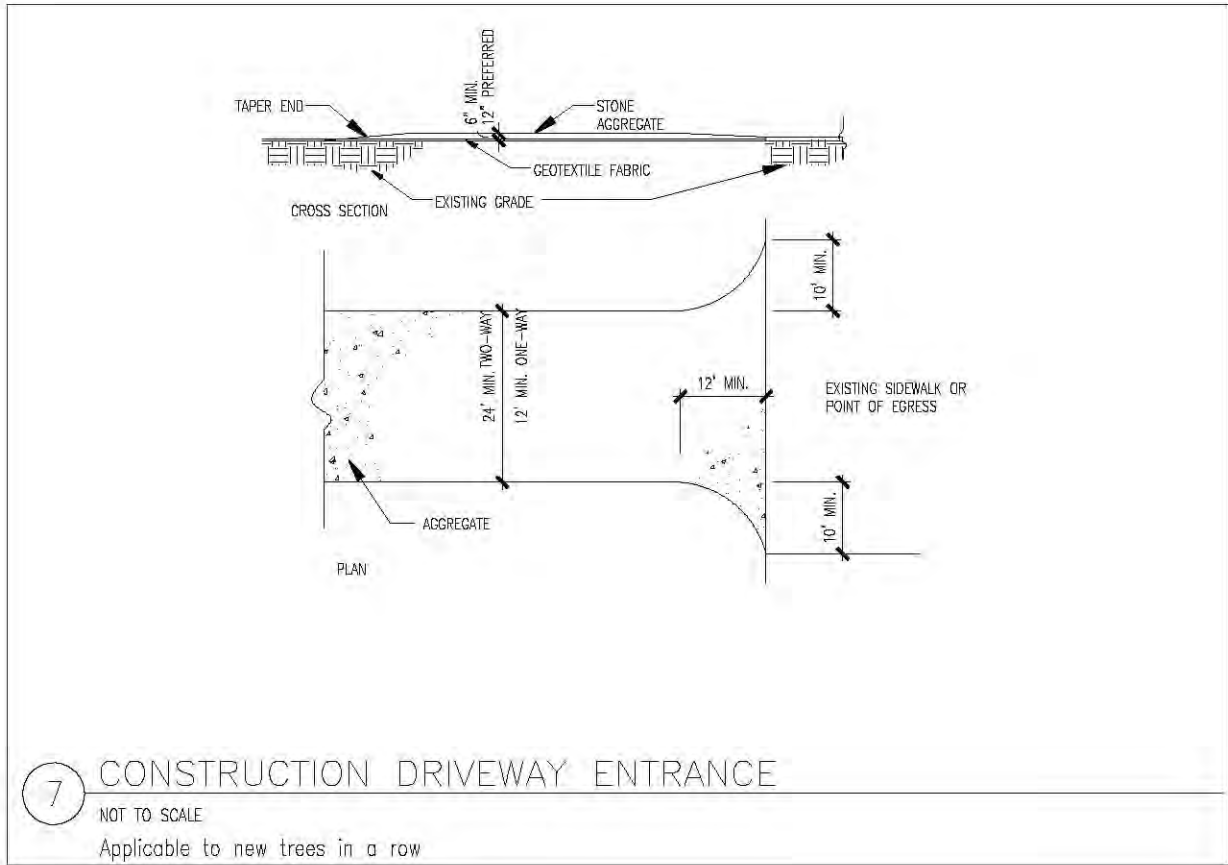



WATER
MANAGEMENT ON
URBAN SITES

WATER MANAGEMENT ON URBAN SITES

Water management in NYC site and landscape architectural design must respond to two fluctuating conditions – too much and too little rainfall – with techniques to control the on-site water, namely:

- **Stormwater Management:** Controlling the water from typical and unusual storms so that it does not damage the vegetation and soils, or does not flood streets and adjacent properties, nor overwhelm the City’s combined and separate sewer system.
- **Water-efficient Landscaping:** Conserving potable water while maintaining healthy plants and an attractive landscape.

This chapter examines the underlying issues of both aspects of water management, and suggest some design and construction techniques to control and conserve water.

STORMWATER MANAGEMENT

Stormwater runoff occurs when precipitation from rain or snowmelt flows over the ground. Impervious surfaces such as driveways, parking lots, sidewalks and streets prevent stormwater runoff from naturally soaking into the ground. Traditionally, the aim of a stormwater management system has been to collect, conduct and dispose of stormwater as efficiently and as quickly as possible. Instead of infiltrating water to the ground, these hard surfaces direct stormwater into the nearest storm drain or combined sewer system. They are so efficient at moving water that the time for stormwater to arrive at any given point in the watershed is very short, translating into large volumes of runoff occurring in a short amount of time. This method of stormwater management can result in serious environmental degradation.

Stormwater can pick up debris, chemicals, dirt, and other pollutants, which can then flow directly into a storm sewer system, lake, stream, river, wetland, or coastal water body. This polluted stormwater runoff can have many adverse effects on plants, fish, animals and people. For example:

- Sediment can cloud the water, reducing oxygen and the penetration of sunlight, and destroy aquatic habitats;
- Excess nutrients in sediments cause algal blooms that also result in drastic reduction of dissolved oxygen in the water and thereby suffocate fish and other aquatic organisms;
- Bacteria and other pathogens wash into swimming areas, requiring beaches to close;
- Debris that is washed into water bodies can choke or disable fish and aquatic birds;
- Hazardous wastes such as pesticides, paints and solvents poison aquatic life, and cause people and land animals to become sick from either ingesting the contaminated water or fish in whose fat these contaminants accumulate.

New York City stormwater can cause additional pollution of a different kind, since NYC has a combined sewer system in many areas, which means that the same sewer lines that carry sanitary sewage also collect the storm runoff. Intense storms can flood this system with more than NYC’s sewage treatment plants can handle. The result is a Combined Sewer Overflow event (CSO), in which the overflow of untreated stormwater and septic sewage is discharged directly into natural water bodies. Studies show that untreated urban stormwater runoff generated during the first hour of intense storm events – referred to as the “first flush” – can have even greater pollutant concentrations than raw sewage. During wet weather events, large quantities of untreated sewage and stormwater contaminated with surface pollutants discharge into the New York Harbor by way of more than 494 combined sewer outfalls.¹

Precipitation amounts have increased in the mid and high latitudes, often in excess of 10% since the turn of the {20th} century. This is especially important because once soils become saturated, seemingly small increases in rainfall can cause large increases in runoff, resulting in floods.
“Global Warming and the Earth’s Water Cycles” US Global Change Research Program, October 12, 2003

¹ “Water Efficient Landscaping: Preventing Pollution & Using Resources Wisely” www.epa.gov/watersense/docs/water-efficient_landscaping_508.pdf

Landscape design strategies can slow down the flow of water across the site, absorb it and cleanse it. Designers have creative opportunities to express the processes of water collection, retention, filtration and release of stormwater that can be as educational and attractive as they are instrumental to improving the urban environment.

WATER-EFFICIENT LANDSCAPING

Just 1% of the entire water supply in the world is available for human use; the rest is salty or locked in ice caps and glaciers. NYC Department of Environmental Protection has a target goal to reduce water consumption in the City by 5% over the next several years and NYC Local Law 86 seeks to reduce water consumption in new public buildings by as much as 30%. According to the U.S. Geological Survey, of the 26 billion gallons of water consumed daily in the United States, approximately 7.8 billion gallons, or 30%, is devoted to outdoor uses. The majority of this is used for landscaping.¹ Rethinking how landscapes are designed can save significant quantities of water and engender the following benefits:

- Significantly reduce demand for irrigation (potable) water, by using native and other “climate appropriate” landscape materials;
- Decrease energy use and air pollution because less pumping and treatment of water is required;
- Save water as well as time and money spent mowing, fertilizing, removing green waste and maintaining landscapes, by limiting the use of turf and other irrigation-requiring vegetation;
- Reduce runoff of stormwater and irrigation water that carry sediments, fertilizers and pesticides into receiving water bodies;
- Encourage plants to develop a self-sustaining root system capable of withstanding moisture fluctuations, by not watering in excess of a plant’s essential need.

LAWS, RULES AND REGULATIONS

SUMMARY – LAWS, RULES AND REGULATIONS

See text and web links below for more information. Refer to chapter: Minimize Site Disturbance for Laws, Rules and Regulations pertaining to runoff from construction sites. Not included are regulations pertaining to private sewers and private pumping stations. This is a summary of key regulations, not necessarily all that may apply.

AGENCY	LAW, RULES, AND REGULATIONS 2008	APPLICABILITY
US Environmental Protection Agency (USEPA)	Section 401 Permit; Section 301, 302, 303, 306, 307 certifications	Fresh and tidal wetlands; sewer outfall construction; effluent limitations for point source discharges etc.
NYS Department of Environmental Conservation (DEC)	No Exposure Certification Form	Industrial activities and materials must be protected by a storm resistant shelter to prevent exposure to runoff
	SPDES Multi-Sector General Permit GP-o-06-002	Permit required for stormwater discharge associated with industrial activity
	Tidal wetlands permit	Construction of or disposal into a sewer outfall
	Tidal wetlands permit	Restriction on activities allowed in and adjacent to a wetland (150 feet landward)

	Freshwater Wetlands Permit (Joint application with USACOE Section 404 and/or Section 10 Permit)	NYS mapped freshwater wetland
NYC Charter	Local Law 86	Water efficiency for new building construction over \$2M
NYC Department of City Planning	Article IV, Chapter 4: Accessory Off-Street Parking and Loading Regulations	Mandates landscape areas with stormwater BMPs for commercial and community facility off-street parking lots
NYC Department of Parks and Recreation	NYC Street Tree Planting Guidelines April 2008	Mandates street tree pit size, soil type and species designed to absorb runoff
NYC Department of Transportation (DOT)	Street mapping or demapping action; (May also require ULURP application)	Change to city street network
NYC Department of Environmental Protection (DEP)	Drainage Permits for house connections to sewer system (SD-1, SD-2); Drainage Plan; sewer capacity assessment, drywells; detention facilities: Administrative Code Title	New development, new site connection, building additions; modifications to site coverage/ land use
	Local Law 71	Regulations specific to sites within the Jamaica Bay Watershed
NYC Department of Buildings (DOB)	House sewer connections; retention and recycling of stormwater; Administrative Code, Title 28	Stormwater discharge; roof leaders; green and blue roofs
	Definition of soils (Soil classifications 6-85, 7-85, 8-65)	Conformance required for leaching pits and dry wells
NYC Office of Environmental Coordination (OEC)	Local Law 33	Regulates construction in the 100-year floodplain including buildings, streets and utilities
NYC Department of Health and Mental Hygiene	Drainage plans; water reuse systems; Administrative Code Title 17 and 24	Regulates reuse of greywater and rainwater; regulates standing or ponding water
Metropolitan Transportation Authority (MTA)	Phase II Stormwater Management Program	Roads, bridges and tunnels under the jurisdiction of the MTA
US Army Corps of Engineers (ACOE)	Section 10 Permit of the Rivers and Harbors Appropriations Act Section 404 Permit	Construction of or disposal into a sewer outfall; discharge of fill or dredged material
NYS Department of State Coastal Zone Consistency Review	Waterfront Revitalization of Coastal Areas and Inland Waterways Act (Executive Laws Sections 910-921)	Projects that fall within any one of the 15 Significant Coastal Fish and Wildlife Habitats in New York City or within the 100-year floodplain

Web links – Note that full regulations not always available on-line.

US Army Corps of Engineers www.usace.army.mil/inet/functions/cw/cecwo/reg/

NYS Department of Environmental Conservation www.dec.state.ny.us/website/dow/mainpage.ht

New York State Stormwater Design Manual

NYC Department of Environmental Protection www.ci.nyc.us/html/dep/watershed/html/regulations.html

NYC Department of City Planning

Waterfront Revitalization Program www.ci.nyc.ny.us/html/dcp/html/wrp

Special Natural Area District www.nyc.gov/html/dcp/html/snad/index.shtml

Street Tree Text Amendment www.ci.nyc.ny.us/html/dcp/pdf/street_tree_planting/proposed_text.pdf

NYC Office of Environmental Coordination www.nyc.gov/html/oec

LEED AND WATER MANAGEMENT

With the enactment of Local Law 86 of 2005 (effective January 1, 2007), the City now requires most of its projects to meet the Silver level of the LEED certification process of the U.S. Green Building Council (USGBC). Water management has two aspects that relate to LEED credits – stormwater management and water efficient landscaping.

Stormwater management credit SS 6.1 is aimed at controlling the quantity of stormwater runoff, and may be achieved by minimizing impervious surfaces and increasing on-site infiltration. The companion credit SS 6.2 is aimed at reducing water pollution by increasing infiltration and controlling the quality of any stormwater runoff. Natural and structured treatment systems are discussed in this chapter. Stormwater management also contributes to the SS Pre-requisite, Construction Activity Pollution.

To achieve the Water Efficiency credits WE 1.1 and WE 1.2, an efficient irrigation system must be used, or no irrigation system at all. One year of irrigation is allowed for initial plant establishment. Using grey water for irrigation will also achieve this point, as well as contribute the credit WE 2 for Innovative Wastewater Technologies, and WE 3 for Water Use Reduction.

LEED CREDITS

Water Management can contribute to the following LEED credits:

Sustainable Sites:

Credit SS Pre-requisite 1 – Construction Activity Pollution Prevention

Credit SS 6.1 – Stormwater Management – Quantity Control

Credit SS 6.2 – Stormwater Management – Quality Control

Water Efficiency:

Credit WE 1.1 Water Efficient Landscaping – Reduce by 50%

Credit WE 1.2 Water Efficient Landscaping – No potable water or No irrigation

Credit WE 2 Innovative Wastewater Technologies

STORMWATER MANAGEMENT - KEY ISSUES

When water, soil and vegetation are purposely introduced into a site, four beneficial functions result: water is soaked into the soil and absorbed by vegetation; water is cleansed as it flows over and through vegetation and soil; water is transpired by vegetation; and precipitation is intercepted by vegetation. The combination of these functions reduces combined sewer overflows (CSO) events, lowers temperature of runoff reaching streams, wetlands and water bodies, recharges groundwater and greatly reduces pollutant levels conveyed by storm sewers to surrounding water bodies.

The planning and design objectives for stormwater management should be to:

- **Reduce** runoff quantity by using infiltration strategies that lessen the amount of water entering, and therefore discharging, into receiving waters;
- **Detain** stormwater runoff temporarily to reduce peak runoff rates to the sewer system and pollution control plants;
- **Treat** stormwater runoff to reduce constituents that cause water pollution.

BASIC UNDERSTANDING OF STORMWATER

Stormwater is water from rain or melting snow that does not soak into the ground but flows into waterways. It runs off rooftops, over paved areas and bare soil, and through sloped landscapes while picking up a variety of materials on its way. As it flows, stormwater runoff collects and transports soil, animal waste, salt, pesticides, fertilizers, oil and grease, debris and other potential pollutants. The velocity and quality of runoff is affected by a variety of factors and depends on the season, local meteorology, geography and upon activities and land uses which lie in the path of the flow.

The Federal Clean Water Act of 1972 had a remarkable effect on the health of the nation's waters by regulating allowable water pollution levels, outlawing illegal pollutant discharges, and funding the building of new sewage treatment plants. New York City currently operates 14 water pollution control plants (WPCPs) as well as 2 CSO facilities. Seventy percent of the NYC sewer system collects both raw sewage and stormwater; these combined sewers convey all flow to the WPCPs for treatment. New York City is now able to treat all sewage generated under dry weather conditions. However, during intense rainstorms, WPCPs and sewer pipes are not always able to handle the sudden surges of water into the system; so when these systems flood, this mixture of stormwater runoff and sewage bypasses the treatment plants and is released into local water bodies via combined sewer outfalls. Such an event is known as a combined sewer overflow (CSO). Approximately 70% of the City's sewers are compound.² CSO events in New York City can occur during rainfall events as small as 0.05 to 0.1 inches per hour. Reducing the volume of stormwater entering the City's sewer system would eliminate the potential overflow of untreated wastewater into the harbor and minimize the need for costly retrofitting of the pollution control infrastructure.

Construction activity can increase the potential for soil erosion and sedimentation of water bodies. Preventing stormwater that transmits new or increased levels of pollutants into the City's water bodies should be a concern for virtually every construction project that will increase its amount of impervious surface. If the foregoing applies to your project, you must perform a variety of engineering calculations and obtain various permits. Following is an abbreviated listing of such tasks:

- Calculate pre-development and post-development stormwater volumes entering the sewer system; total area is a critical measurement (in square feet) of the amount of water runoff generated by a storm event;
- Provide for stormwater management on site including structural or bioengineered systems and calculate the peak discharge rate of stormwater;
- Estimate types of pollutant loadings resulting from stormwater discharge;
- Based on the quantity and quality of stormwater being discharged, assess the effects on the receiving water body;
- Investigate the existing infrastructure condition pertaining to stormwater discharge (combined vs. separated sewer or direct discharge into a water body);
- Find out NYC DEP's drainage plan and design capacity for the specific site.

For a complete description of tasks and calculation methods, refer to NYC CEQR Manual; TR-55 computerized model by the US Department of Agriculture, Soil Conservation Service; and NYC DEP Criteria For Determining Detention Facility Volume. For a complete description of tasks and calculation methods, refer to NYC CEQR Manual; TR-55 computerized model by the US Department of Agriculture, Soil Conservation Service; and NYC DEP Criteria For Determination of Detention Facility Volume. At the present time, NYC regulations require that all detention or other techniques for stormwater management must be designed with underdrains or overflow devices.

2 *New York City Department of Environmental Protection. "New York City's Wastewater Treatment System"*

DEFINITIONS

The following are useful definitions of terms frequently found in stormwater management design:

Design storm: Design storms are hypothetical planning storms that have been developed by statistical analysis of long term precipitation records. They are used in runoff calculations to predict runoff peak and volume. Thus, for example, a 100-year design storm should produce a 100-year amount of runoff and water volume. NYCDEP uses a fixed number for stormwater runoff calculations in New York City – 5.95 inches/hour – equivalent to about a 5-year rainfall frequency event, though there are areas of the City where sewers were designed to more frequent events (1,2, and 3-year intensities) and thus are more susceptible to flooding.

Impervious Surface: Any area that does not readily absorb or retain water. Impervious (or impermeable) surfaces include building roofs, paved roadways, parking lots, driveways, and sidewalks, paved recreation areas, and heavily compacted, exposed soils. As the impervious areas within a watershed increase, the volume and velocity of surface runoff increases, which reduces groundwater recharge, increases erosion, overwhelms sewers, causes waterways to become wider and straighter, and reduces waterway habitat. While impervious surfaces are not the direct basis of non-point source pollution, they do prevent pollution cycling in soils and increase the flow of pollutants into waterways.³

Surface Runoff: The portion of rainfall or irrigation water that does not infiltrate into the soil, but travels over the soil surface to the nearest sewer or stream channel. It is also defined as that part of the runoff of a drainage basin that has not passed beneath the surface following precipitation.⁴ The rate of runoff is influenced by the intensity and duration of rainfall, the type and moisture condition of the base soil, surface slope and length, and the permeability of any constructed/installed surface

Bioretention: A water quality and water quantity control practice using chemical, biological and physical properties of plants, microbes and soils for removal of pollutants from stormwater runoff. Bioretention depends on the natural cleansing processes that occur in the soil/mulch/plant community, and establishes a self-perpetuating system if properly designed. Bioretention facilities capture stormwater runoff that is then filtered through a prepared soil medium. Sediments and suspended solids are trapped in the mulch layer prior to entering the soil.

Bioretention areas can take many shapes and sizes since their design is a combined function of anticipated runoff and specific site conditions – topography, drainage area, site soils etc.



Photo: Matthews Nielsen Landscape Architects

Porous pavement in a parking lot

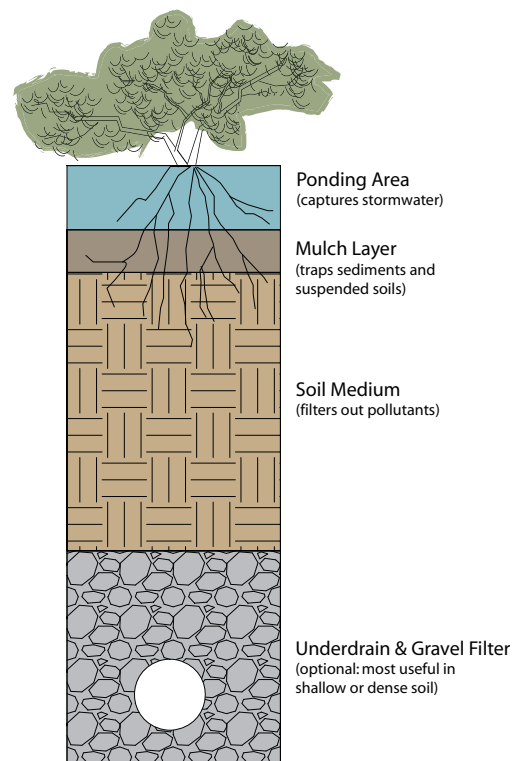

Bioretention profile

³ Arnold, C. and C. Gibbons. *Impervious Surface Coverage: The Emergence of a Key Environmental Indicator*. *Journal of the American Planning Association*, 62(2), pp.243-256, 1996
< http://www.nyc.gov/html/dep/html/harbor_water/wwwsystemprocess.shtml>

⁴ USGS Flood Definitions: <http://ks.water.usgs.gov/Kansas/waterwatch/flood/definition.html>

Absorption: The action of water movement into the spaces between soil particles and then is taken up by plant roots.

Filtration: Practices that capture and temporarily store runoff, and strain out undesirable particles using various media. Filtration media include sand beds, organic matter, geotextile fabrics, soil or other acceptable treatment materials.

Infiltration: The downward migration of runoff through the planting soil and into surrounding soils. Infiltration practices capture and temporarily store the runoff before allowing it to infiltrate into the soil.

TECHNIQUES FOR MANAGING STORMWATER

SUMMARY - KEY TECHNIQUES

See text for more detail.

STORMWATER TECHNIQUES	APPROPRIATE APPLICATIONS	RESOURCES
HARDSCAPE TECHNIQUES		
Pervious Paving	Parking lots, plazas, pedestrian paths, overflow parking areas, paved play fields, bike paths	Diagram/ Details
PRE-TREATMENT TECHNIQUES		
Filtration Basin/Sand Filter	Fueling areas, truck washing areas, outdoor storage areas containing products that could contaminate soil	Diagram
Vegetative Filter/Buffer	Parking lot islands, perimeter landscaped areas adjacent to paved areas	Diagram
Bark Beds	Parking lot islands, perimeter landscaped areas adjacent to paved areas	–
Catch Basin Inserts	Loading docks, fueling areas	–
STRUCTURAL TECHNIQUES		
Planters	Entry plazas, elevation changes adjacent to steps or ramps	Diagram
Storage/Infiltration Beds	Under paved or planted areas where soil has good percolation	–
Water Quality Inlets	Parking lots, loading docks	–
Drywells	Under paved or planted areas where soil has good percolation	–
Subsurface Detention Tanks	Where soil has poor percolation and where sewer capacity is limited	–
Rooftop Detention Green and Blue Roofs	Where structural capacity, roof slope and waterproofing system permit	Photo
Rain Barrels/ Cisterns	For low volume rainwater collection	Photo
BIOENGINEERED TECHNIQUES		
Infiltration Areas	Landscaped area, courtyards, plazas, parking lot islands	Diagram
Tree Pit Enhancement	Sidewalks, plazas, courtyards	–
Infiltration Swale	Parking lots, road edges, narrow landscaped areas where soil has good percolation	Diagram

Rain Garden/ Bioretention	Small landscaped areas under downspouts or impervious surfaces	Diagram
Underdrained Bioretention	Plazas, parking areas or roads where soils exhibit poor percolation	Diagram
Recharge Basin	Plazas, parking areas or roads when site is located over an aquifer	–
Slope Reduction Bench	Large to medium-sized sloping vegetated area	Diagram
Shoreline Restoration	Any site adjacent to a freshwater or intertidal wetland, fresh, brackish or salt water body	–
Plant Material/Design	Any application of vegetation used for bioengineered stormwater management	Plant list
Vegetated Roof	Any flat or gently sloping roof with adequate structural capacity (see DDC <i>Cool and Green Roofing Manual</i>)	–
Berms	Medium to large sites whose construction will generate excess soil	–

Initial planning and design decisions need to identify the goals of its stormwater management program. This includes determining the amount of runoff that will be allowed to leave the site pursuant to DEP regulations, LEED™ goals, etc, and the manner in which runoff will be reduced, treated, and detained. These decisions need to be made in conjunction with local and site-specific data, including topography, drainage basins, existing size and type of sewers, and soil characteristics. Knowledge of these factors helps determine appropriate stormwater management measures. (see also “Soil Testing Requirements” later in this chapter).

At a minimum, the design should not increase the volume of runoff leaving the site, compared to the pre-existing condition. Even better is to achieve “zero runoff” wherein all stormwater is captured, detained and absorbed on site. A “treatment train” of stormwater techniques utilizes a variety of methods to create synergy among natural systems, as well as providing a back-up for extreme storm events. Specifically, these techniques for stormwater management are grouped into four categories of strategies:

Hardscape Techniques: Design decisions that reduce runoff. Minimize the amount of impervious surface to only what is required by the program; Limit the use of turf grass and create “absorbent landscapes.” Refer to the chapter: Maximize Vegetation.

Pretreatment Techniques: Techniques that provide initial treatment and reduce the velocity of stormwater before it enters a downstream conveyance or outlet. Use vegetated filter and buffer strips to remove large sediments, debris and chemicals from stormwater before it enters downstream systems; Use catch basin inserts to remove floatables from entering systems; Use specific drainage structures that help improve water quality - such as oil and grit separators - to remove sediments and hydrocarbons before they pollute waterways.

Structural Techniques: Techniques that use physical means to control and treat runoff; useful in conditions where bioengineered solutions cannot work. Use detention structures to slow the velocity of runoff and temporarily and store it during peak flow periods; Use infiltration structures (both surface and underground) to reduce peak flows, improve water quality and promote groundwater recharge.

Bioengineered Techniques: Systems that mimic natural hydrology and ecology, and rely on natural processes to reduce and treat runoff. Employ bioretention techniques that may be used to direct runoff into the municipal storm sewer, to infiltrate runoff or to provide a combination of conveyance and infiltration; Create constructed wetlands, or permanent non-stagnant pools of water, planted with appropriate associations of vegetation (aquatics, emergents), that are designed to reduce, detain and treat stormwater runoff; Design natural or naturalized edges at the interface between the upland and the shoreline of rivers, lakes or estuaries.

HARDSCAPE TECHNIQUES

One of the basic considerations in limiting the generation of runoff is the permeability of the site – the ability of the site to absorb the stormwater before it becomes runoff. Refer to the Minimize Site Disturbance chapter for a discussion of appropriate soil and subsurface geologic conditions that are suitable for these applications. Creating and conserving planted areas is one technique, as is limiting the amount of paved area. For those areas that must be paved, there are systems that allow water to penetrate and be absorbed into the soil. These include porous paving and permeable paving systems.

POROUS PAVEMENTS

These are asphalt or concrete pavements in which the fines – the smaller particles in the mix of aggregate materials comprising them – have been held to a minimum to allow stormwater to pass through the pavement. Beneath the porous layer of pavement is a uniformly graded bed of clean stone with a minimum void space of 40%, laid in sufficient depth to catch and store a calculated volume of stormwater as it drains through it. The bottom of the stone bed is underlain with filter fabric to allow water to then infiltrate into the native soil, and to prevent soil from migrating upward into the voids of the stone base. When planning areas to be paved with permeable pavements, it is important to note that the permeability of underlying soil subgrades are usually less than the surface infiltration rates, so it is good practice to design the base layer to be able to store 100% of the stormwater volume anticipated to infiltrate the area. It is often necessary to include an overflow control structure (underdrain pipe) so that during large storm events, water will not rise to the pavement level.

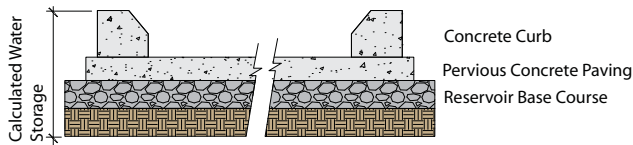

Porous concrete pavement

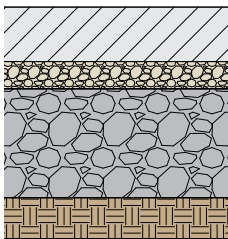

Porous asphalt pavement

Porous Asphalt Surface Course
1/2" to 3/4" Aggregate Asphalt Mix
Filter Course 1/2" Aggregate, 2" Thickness
Reservoir Base Course
1" to 2" Aggregate
Voids volume is designed for runoff retention.
Thickness is based on storage required.
Filter Fabric

Porous pavements are effective for pedestrian pavements, plazas or parking areas. The lifetime of all porous pavements can be extended by pre-treating runoff. Filter strips or small basins that trap sediments and debris are very effective in reducing clogging of void space. Refer to filtration techniques later in this section.

These porous pavements have some significant limitations:

- Not recommended for slopes greater than 5%;
- Subsoil must have a minimum infiltration rate of 6 to 8 inches per hour, or outlet pipes may be required;
- Minimum depth to bedrock or groundwater should be 3 feet;
- Requires periodic “vacuuming” or power washing to remove fine materials such as mud, sediment, cinders from snow plowing, etc., from clogging void spaces;
- Porous pavements are not permitted for use in the Right-of-Way according to NYC Department of Transportation.

Porous Concrete Pavements: Porous concrete is a structural, open textured paving surface consisting of standard Portland cement, fly ash, locally available open graded coarse aggregate, admixtures, fibers and potable water. When properly mixed and installed, porous concrete has a 17%-22% void space which allows rapid percolation of stormwater. The characteristic of porosity does not limit these pavements in terms of durability or load bearing capacity. Porous concrete is about 85% the strength of conventional concrete; they are good for sidewalks, driveways, alleys, parking lots and plazas.

Porous Asphalt Pavements: Porous asphalt paving consists of an open graded coarse aggregate bound together by asphalt cement with sufficient interconnected voids to provide a high rate of permeability.

PERMEABLE PAVERS

These are modular pavers that contain voids, or create voids in the paved surface that allow the penetration of water. There are 4 categories of porous pavers:

Interlocking Concrete Blocks: These are precast units capable of withstanding AASHTO H-20 (80 psi) loading and may be laid on compacted subgrade or aggregate base with a sand setting bed. The voids between the blocks may be filled with topsoil and grass seed or filled with crushed gravel, sand, or tumbled glass. This system is ideally suited to light use parking areas, fire lanes and tree trenches. When filled with either turf or gravel, the concrete hubs are visible so the appearance is mottled rather than uniform. The units can also be used to stabilize embankments along water courses.

Cast-in-Place Concrete Blocks: These are made with reusable forms and create voids for planting. An advantage of the cast in place system over interlocking concrete blocks is its resistance to differential settlement and frost heave. Residual surface water, or runoff, is held within formed soil pockets thereby controlling the rate of infiltration. As with the interlocking concrete block system, if turf is the selected void infill system, this material is best used on roads and paths that are not traversed on a daily basis.

Flexible Plastic Cellular Confinement Systems: These modular systems used to be known as “reinforced turf systems” before their stormwater advantages became known. The system acts as a load-bearing surface that protects herbaceous vegetation from compaction. High void spaces within the cross section foster good root development, storage capacity for rainfall and runoff cleansing as water moves through the sand/gravel layers. Plant roots help to further breakdown suspended pollutants, particularly hydrocarbons. These systems appear as a uniform surface of grass. A variation on this system is one in which the voids are filled with gravel. Depending on the choice and depth of gravel, these systems can store significant amounts of runoff. Gravel-filled systems have none of the maintenance issues of the turf-filled systems. Both turf and gravel systems are easy to walk on and are suitable for all forms of vehicular and pedestrian applications.

Modular, Molded Plastic Materials: Similar to the flexible cellular confinement systems, the difference being in the manufacturing process. Void in the units may be filled with turf or gravel. All installations of porous modular pavement should be designed and constructed according to the manufacturer’s specifications. Pavements using vegetative infill must be capable of disposing stored water within 24-36 hours to avoid damage to the herbaceous plants. Parking areas should avoid extensive ponding for periods exceeding an hour or two. Other facilities should evaluate the acceptable time limit for infiltration based on performance criteria and function. As with other porous pavements, subsoil infiltration rate will directly affect the success of porous pavers.

MAINTENANCE PRECAUTIONS

With most porous pavers, it is important to remove any deeply-rooted woody plants that may colonize the surface, since they can disrupt the paving and reduce its permeability. Also, snow plow operations must be done carefully since differential settlement may cause “lipping” of the pavers, and if the plow blades or loader buckets are set too close to the surface, they can damage or dislodge the pavers. Maintenance is also required on a routine basis to remove sediments that may void spaces in porous pavements.

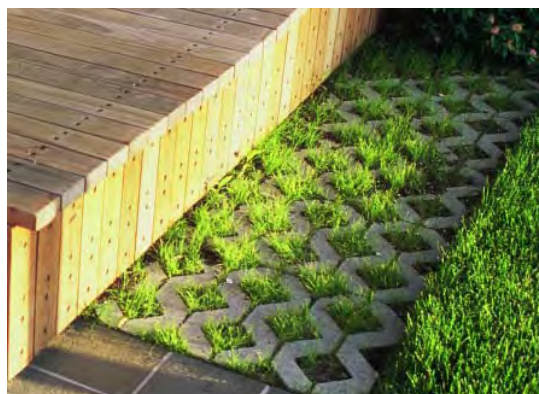

Grass filled and concrete pavers

Photo: Mathews Nielsen Landscape Architects

PRE-TREATMENT TECHNIQUES

These techniques provide initial treatment and reduce the velocity of stormwater before it enters a downstream conveyance or outlet.

FILTRATION BASIN / SAND FILTER

This type of pre-treatment facility is recommended for areas known as “hot spots” where localized contamination is likely to occur. Examples include fueling stations, truck washing areas or outdoor storage facilities of products that could contaminate soil or water. Treatment is accomplished by filtering runoff through soil to an underdrain discharge point. An important filter feature is the impervious liner designed to eliminate the possibility of groundwater contamination. The drain pipe should have the ability to be capped to capture accidental spills and contain contaminants, which can be siphoned off. The filtration media may be sand or soils that are either in situ or imported, depending on infiltration rate. Pre-treatment should trap heavy sediment loads and protect the system from clogging. Sand filters should be inspected every 6 months. Clogged sand may require removal and replacement of the top 2-3 inches. Debris and trash should be removed regularly.

VEGETATIVE FILTER/BUFFER AREA/STRIP

Vegetative filters are gently sloped planted areas and are recommended for use in conjunction with bioretention facilities (see below). Stormwater enters the vegetative filter as sheet flow from an impervious surface, and the plant materials capture sediments before the runoff reaches the bioretention device. Using a vegetated buffer or filter strips to pre-treat stormwater runoff helps reduce maintenance of a bioretention device and extends its longevity.

If flow is concentrated, it should be dispersed over a larger horizontal area (using a spreader check dam). Alternatively the area immediately beyond the flow entry point can be reinforced with “surge stone” or other non-vegetative means of dissipating energy. Obstructions must be cleared and sediment or trash removed regularly. Filter must be a minimum 20' by 10' with a maximum slope of 10%; exact size to be determined based on tributary area, storm event and native soil infiltration rate. Plantings may range from trees and shrubs to perennials and grasses. Overflow and underdrain pipes are recommended.

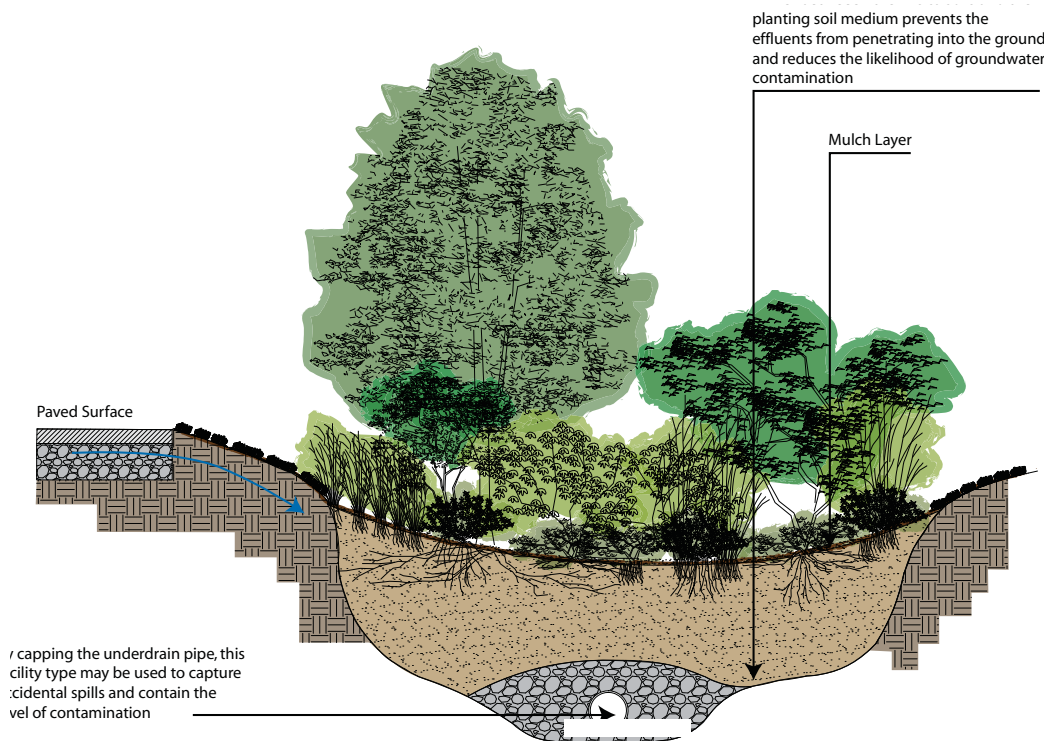

Filtration basin

BARK BEDS FILTER STRIPS

Because bark beds do not freeze, they have an advantage over vegetative strips by filtering year-round, especially when we have a harsh winter in New York. In addition, the bark serves to insulate the underdrain pipes from freezing and the bark helps to breakdown pollutants before they enter subsoils or groundwater. The bark layer is typically 24 to 36 inches over the underdrain. Useful bark types include shredded bark, wood shavings, sawdust or hay bales. Wood chips and grass clippings should be avoided as they tend to float.

CATCH BASIN INSERTS

Catch basin inserts are pre-manufactured units that mount directly into the frame of drainage structures. They work by filtering debris and large sediment particles from stormwater entering the catch basin, and can also include an oil absorbent material to remove deleterious hydrocarbons. Catch basin inserts come in three basic types: 1) Inserts consisting of a series of trays with a sediment trap on top and varying media filters below; 2) Inserts composed of filter fabric; 3) Inserts consisting of a plastic box that filters water and traps debris. Each of these devices holds a smaller volume of runoff than the size of the catch basin itself (up to 60% of the sump volume) so they require frequent maintenance. Frequency will be based on the type of facility and may range from annual to monthly cleaning. Catch basin inserts are highly recommended at such locations as loading docks or fueling areas where there can be high concentrations of spilled, harmful hydrocarbons and oil. For areas where spills of contaminants are likely to occur, catch basins should be fitted with vaults and pumps to contain the pollutants.

The NYC DEP started a floatables reduction program in 2001 and has installed barrier hoods in 130,000 catch basins throughout the city. In addition DEP has installed booms or floating barriers at 23 locations to capture floatables discharged from combined sewers at their outfalls.

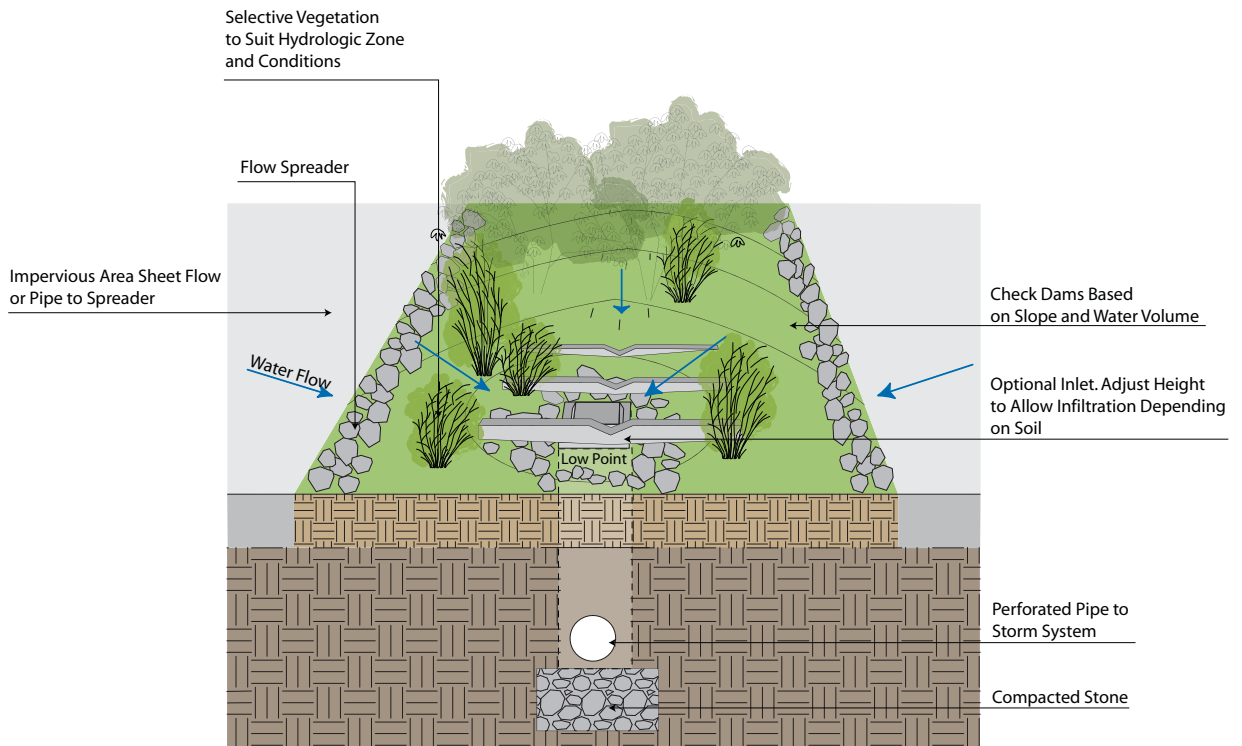

Vegetated filter with under-drain

STRUCTURAL TECHNIQUES

PLANTERS

These are above or below-ground structures that can be used in instances where existing soil conditions or site area does not allow for the use of bioengineered techniques.

Planters With Pervious Bottoms: Planters with pervious bottoms can be used to absorb runoff from downspouts or other impervious surfaces. The planter should be designed to allow runoff to filter through the planter soil and vegetation and then infiltrate into native soils below. The planter should be sized to accept runoff and temporarily store water in a reservoir on top of the soil.

Basic design criteria:

- Topsoil must have a minimum infiltration rate of 2"/hr;
- Sand/gravel/recycled glass aggregate base can be used to store additional stormwater and must be designed for a 30% void space ratio;
- Width/depth of the planter is determined based on native soil infiltration rate, selected storm event and, hence, the amount of surface runoff to be captured;
- Minimum planter width 30" in order to achieve effective plant mass and filtration capacity regardless of stormwater volume;
- Plantings must be selected for moist as well as seasonally dry conditions;
- Provide overflow and underdrain pipes.

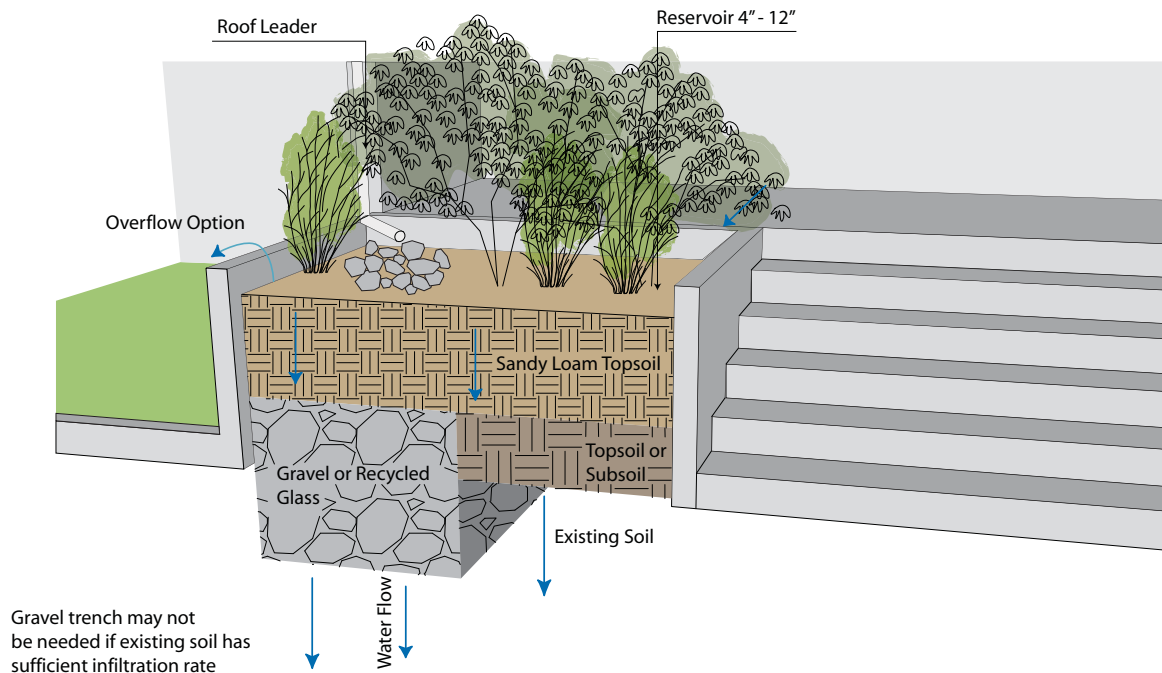

Planters With Impervious Bottoms: planters with impervious bottoms can be used where native soils are either contaminated or not conducive to infiltration. Pollutant reduction is achieved as the water filters through the soil; flow control is obtained by storing the water in a reservoir above the soil. The combined planter, soil, and overflow drain system should be designed to hold water for no more than 4-6 hours after a storm event. Basic design criteria – planters with impervious bottoms:

- Topsoil must have a minimum infiltration rate of 2" per hour;
- Planter must have an outlet pipe with geotextile fabric or drainage blanket to release cleansed stormwater;

- Width/depth of the planter to be determined based on selected storm event and, hence, the amount of surface runoff to be captured;
- Minimum planter width 30" in order to achieve effective plant mass and filtration capacity regardless of stormwater volume;
- Plantings must be selected for moist as well as seasonally dry conditions.

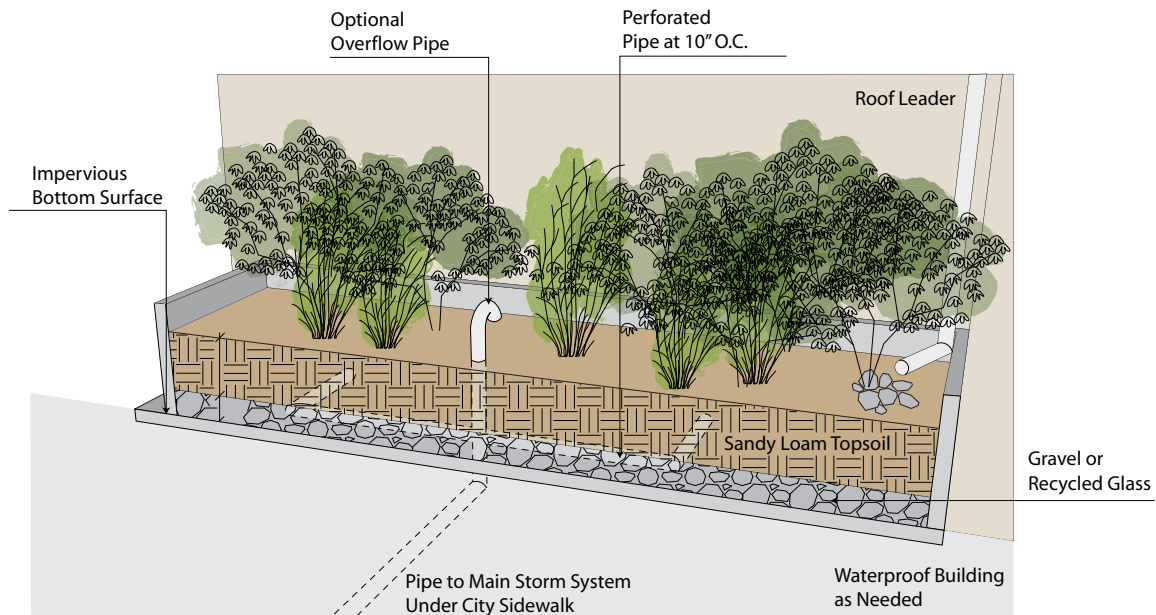

STORAGE / INFILTRATION BEDS UNDER PARKING OR PLANTED AREAS

There are a variety of manufactured products that allows the storage and infiltration of stormwater beneath paved or planted surfaces. Some products are structurally capable of handling vehicular loading. The most cost effective ones are modular systems that they can be installed either vertically or horizontally as site conditions allow. For example, a unit of approximately 9 square feet can store 25 gallons of water. This water may then be released into the soil, retained for reuse as irrigation or released slowly into the sewer system after the storm event has passed.

WATER QUALITY INLETS

Water quality inlets (WQI) are underground structures that can be retrofitted into the existing storm sewer conveyance system, within the space of a conventional manhole cover, to remove sediments and hydrocarbons from the runoff of a small drainage catchment area. Most systems consist of three or more chambers that allow sediments and particulate matter to settle, screen debris and remove oils from stormwater. An example of a simple WQI is an oil and grit separator that is particularly effective in parking lots. Routine maintenance is required for optimum functioning.

DRYWELLS

A drywell is an excavated pit filled with aggregate, its depth typically ranging from 3 to 12 feet, which receives stormwater primarily from roof drainage. Dry wells are most effective where there is low pollutant or sediment loading, where soils are well drained and where bedrock is a minimum 3 feet below. The bottom, sides and top surfaces of the well need to be lined with filter fabric to prevent passage of silt and fines. The interior of the well is filled with drainage stones, usually 1.5 to 3 inches in diameter. Good construction monitoring is essential to ensure the system is properly installed.

DETENTION TANKS

A detention tank is an underground storage facility that receives and temporarily holds stormwater, generally from rooftops. The tanks can be constructed of metal, durable plastic or concrete, and designed for constant or controlled outflow. New York City DEP requires on-site retention of storm runoff in excess of the specific amount allowed under the approved Drainage Plan for your project area. Design of these tanks is proscribed by DEP in Criteria for Determination of Detention Facility Volume, June 1992, revised September 2006. It is available on DEP's website.

http://home2.nyc.gov/html/dep/pdf/water_sewer/30.pdf

GREEN AND BLUE ROOFS



photo: Mathews Nielsen Landscape Architects

Blue roofs detain stormwater

Because of their ability to absorb and retain stormwater, green roofs are a strategy for reducing, slowing and filtering runoff. A sandwich of components and systems make water accessible to plant roots, which is then absorbed and released into the atmosphere through evapotranspiration. Long term success with green roofs is dependent upon proper design of the system and proper installation. Recent technological advances in roofing components have resulted in available products with warranties comparable to conventional roofing assemblies. The design challenge lies in determining the right balance among the building structure, allowable weight load (soil depth), use and accessibility, and cost. These decisions will then determine the appropriate system and plants. Refer to the DDC publication *Cool and Green Roofs*, available on DDC's sustainable design website.

Blue roofs, or controlled flow roofs, are engineered to detain stormwater and release it at a determined discharge rate. This is achieved either by using drains with collars to allow ponding, by installing roof leaders that are undersized in diameter or by reducing the slope of a roof to $\frac{1}{4}$ inch per foot. The benefit of blue roofs is to detain runoff from entering the sewer system during the storm peak so as to avoid a CSO event. NYC's Department of Environmental Protection (DEP) credits blue roofs under its detention requirements.

BIOENGINEERED TECHNIQUES

These are integrated systems that are designed to mimic natural hydrology and ecology, and rely on their biological, physical and chemical processes to reduce and treat runoff.

INFILTRATION AREA

Infiltration areas are portions of a site that exhibit proper soil permeability to be utilized to capture, filter and infiltrate stormwater. These areas can be integrated into a site's landscape to be aesthetically formal or informal in character. They are designed to capture runoff from impervious areas and are effective in courtyards, plazas or parking lot islands, or as landscaped zones around a building. The system works by holding runoff and allowing pollutants to settle as runoff infiltrates. Basic design criteria:

- Minimum dimension is 4 feet in any direction and needs to be sized based on the storm event, contributory runoff area and infiltration rate of the native soil;
- Installed topsoil must have an infiltration rate of 2"/hr;
- Overflow pipe and underdrain is recommended;

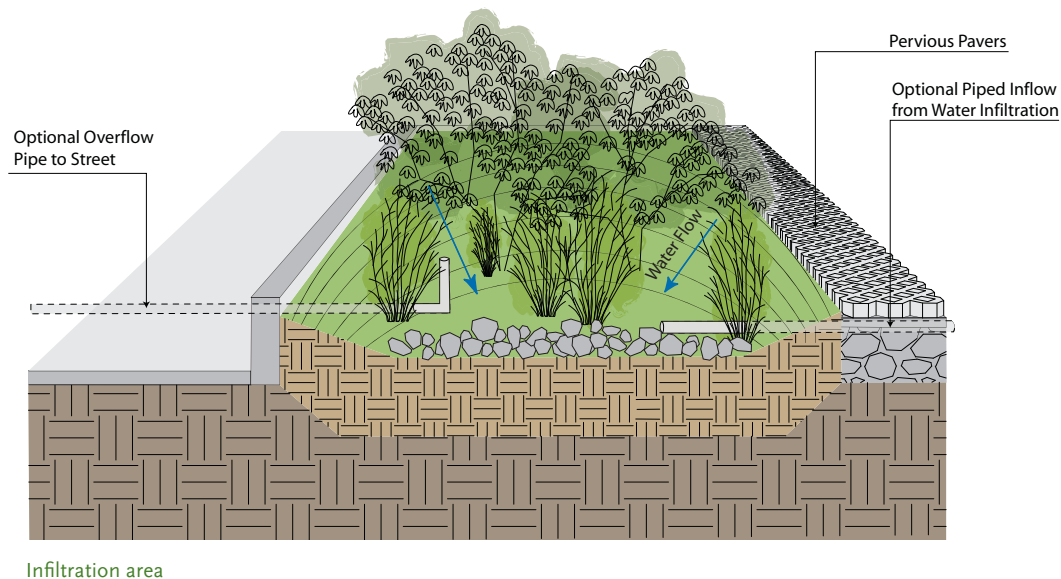

Infiltration area

Infiltration areas include all of the types described below.

TREE PIT ENHANCEMENT

This technique entails either increasing the size of street tree pits or designing trenches – backfilled with structural soil – that interconnect several street tree pits below the sidewalk surface. (refer to chapter: Maximize Vegetation for detail) These enhanced tree pits serve to store runoff falling on the tree pit, as well as collecting and storing runoff from tributary sidewalk, plaza or paved areas.

Basic design criteria:

- Specify structural soils to have 25-30% void space to capture runoff for uptake by tree roots;
- Minimum dimension of tree pit to be 5' wide; with 4' permitted in constricted sidewalk conditions;
- Minimum dimension of tree pit to be 10' long; with 15' to 20' preferred;
- Maximize interconnected tree pits; no maximum length restrictions except as required for street utility appurtenances (hydrants, light poles);
- Locate tree trenches adjacent to paved areas with cross slope to trench between 1%-5%.

INFILTRATION SWALE

Landscape swales are planted areas with a slight depression of 6" to 12" that allow runoff to enter, infiltrate and flow through them. These swales are usually long and narrow, making them well suited to parking lots, road edges or narrow landscaped spaces. Swales may be planted with a variety of herbaceous species, with trees and shrubs adjacent to the channel. For swales that carry large volumes of water or have steep slopes, structural solutions (e.g. check dams, armored slopes) are required. Swales capture pollutants as runoff is detained and absorbed in the soil. Groundwater recharge is increased by check dams since they slow overland runoff velocity and increase infiltration. Basic design criteria:

- Swales with longitudinal slopes in excess of 6% should have check dams. A check dam is a small barrier, usually of stone, built across the direction of water flow. These help to slow the water's velocity and encourage the impounded water to infiltrate the surrounding soil;
- Cross-sectional dimension of a swale is dependent on the extent and imperviousness of the tributary area, length of the swale itself and the design storm event. Provide for a minimum of 6 inches and a maximum of 12 inches of stormwater ponding;
- Side slopes of the swale should not exceed 3H:1V for safety and erosion control.
- Linear slope of the swale should be between 2%-4%. Slopes in excess of 4% will require check

dams and may require an “armored” channel in lieu of herbaceous plants. Armoring can be accomplished with large stones, gabion, special fabrics or precast concrete units;

- Swale outlet or spillway needs to be made of a non-erodible material; swale also may discharge into a culvert or pipe for conveyance to a stream or sewer. Surface ponding must drain in at least 24 hours otherwise underdrainage is required.

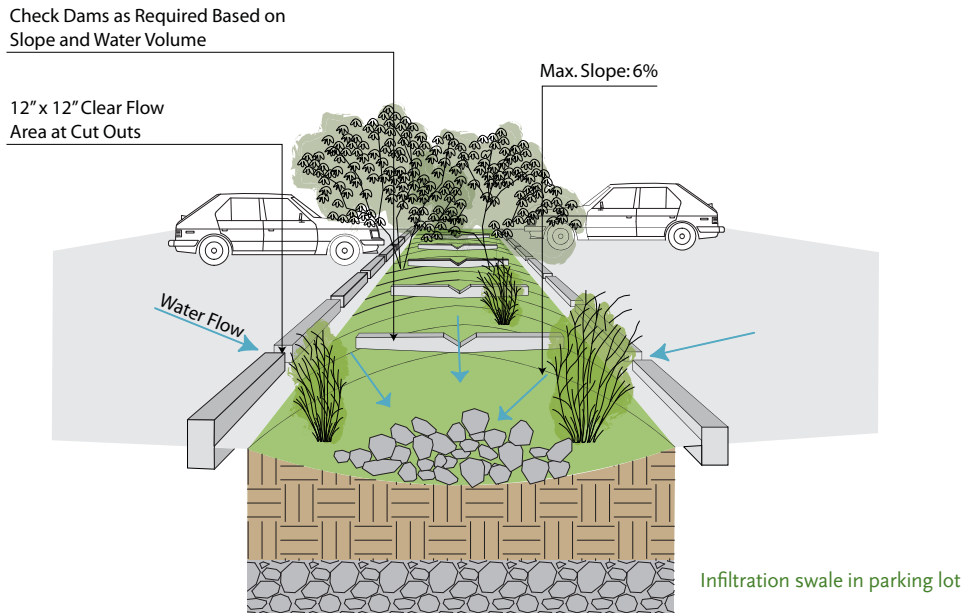

INFILTRATION TRENCH

An infiltration trench is essentially a storm sewer that is designed to leak. The system is comprised of an inlet pipe or other directed water source, a perforated distribution pipe, layers of drainage gravel and an overflow to the storm drainage system. The perforated pipe is set in a bed of stone wrapped in filter fabric with soil and a surface swale located above the pipe. For more on the subject of filter fabric, refer to the later paragraph “The Great Debate: Geotextiles vs. Granular Blankets”. The trench should be continuously sloped to avoid erosion. The surface of the trench may be planted or remain a stone-filled trench. Infiltration trenches are effective when located adjacent to parking lots, roads or narrow side yards, and also may be used to accept roof runoff or footing drains. Infiltration trenches do not cleanse runoff unless pre-treatment is provided.

Basic design criteria:

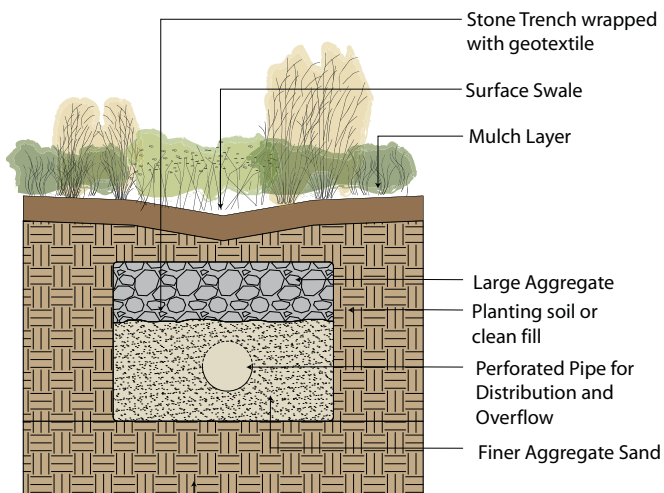

Infiltration trench

- Locate infiltration trenches downhill of building walls, and at least 10 feet from a building.
- Trench bottoms range in width from 2 to 8 feet.
- If pollutants from runoff (sediment of chemical) are known to exist, provide pre-treatment filter zone or catch basin with a sump and oil/grease trap.
- Locate above ground water.

RAIN GARDEN / BIORETENTION BASIN

A rain garden (or bioretention basin) is an absorbent landscape designed for a low-lying area, placed over a geotextile fabric that protects an underlying stone layer from sedimentation. It is a low impact way to remove pollutants from the stormwater runoff from impervious surfaces. Runoff that flows into the rain garden will temporarily pond before being absorbed into the planting soils, stone layer and native soil. Maintenance is no more cumbersome than for any landscaped area. To ensure continued high performance of the rain garden, compacted surface soils should be periodically scarified to maintain infiltration rate. Basic design criteria:

- Growing medium to be 18" to 36" deep, depending on the plants desired, contaminants to be removed and soil characteristics;
- Stone underlayer to be 12" to 18" deep;
- Linear bioretention systems should be minimum 4' wide with slopes under 4%. Slopes greater than 4% will require check dams. Flow enters either through overland sheet flow or by cuts in curbs;
- Curb cuts should be frequent (10' o.c.) and need to be cleaned annually;
- Depth of ponding zone should be between 3-4 inches to allow for dissipation of water within a 3-6 hour period. Overflow and underdrain pipes are recommended.



Raingarden example



Raingarden example with underdrain

UNDERDRAINED BIORETENTION FACILITIES

Once the soil's pore space capacity is exceeded, stormwater begins to pool at the surface of the planting soil; therefore, a complete design for a bioretention area must consider techniques to handle overflow or system failure. This can be accomplished by an underdrain system, which provides a conduit that is connected to a discharge facility or other stormwater management system (storm drain, stream or underground storage tank, conventional sewer). The underdrain system can be constructed of perforated pipes, gravel layers and collector pipes. Typically, underdrains are not required where soils below the bioretention facility have an infiltration rate greater than 1 inch per hour and where the water table depth is greater than 2 feet below the lowest elevation of the bioretention area. Percolation tests are required to determine the appropriate overflow method.

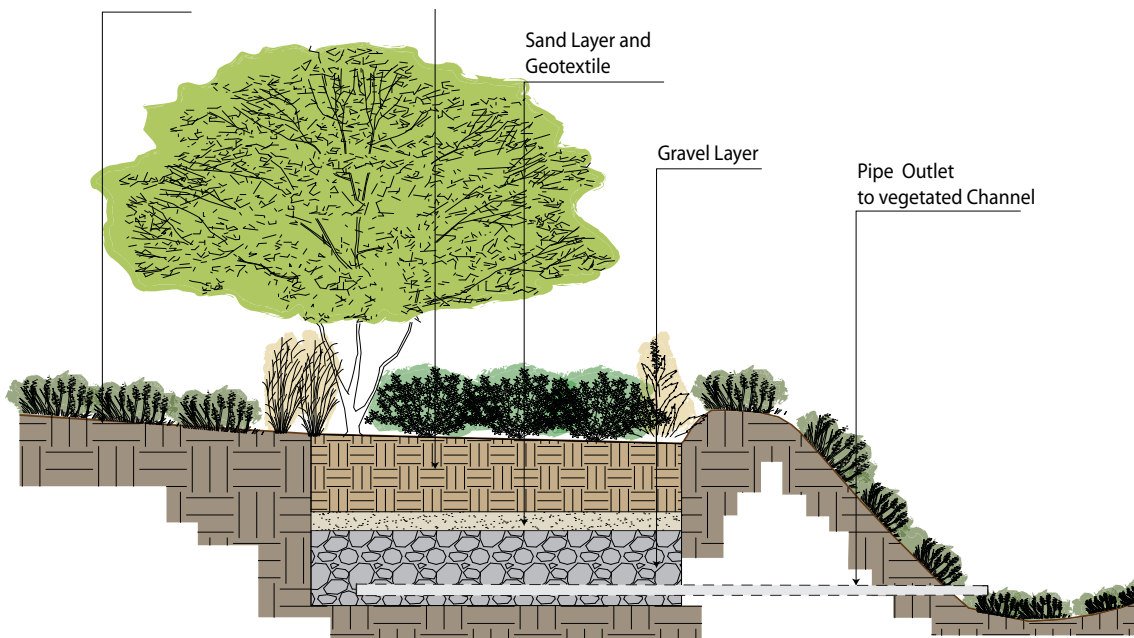

Bioretention with underdrain

RECHARGE BASIN

This type of facility is used where high recharge of ground water would be beneficial, for example, in areas over the Long Island aquifer. Because there is no underdrain, the in situ soils need to have a high filtration rate to accommodate the inflow levels (minimum 1 inch per hour). These facilities may need to be fenced since standing water may occur over a sustained period.

SLOPE REDUCTION BENCH

This technique involves reshaping sloped ground surfaces to control stormwater and minimize erosion. The benches are broad terraces that redirect water flow along parallel contours as opposed to allowing water to travel directly downhill. This technique slows the velocity of runoff, thereby reducing the likelihood of erosion and minimizing concentration of water at the point of collection. Delayed time of concentration is critical to reducing CSO events. This technique should not be used where large areas of existing vegetation are to be protected since the effect of cut and fill will have an adverse impact on existing grades. See the following following diagrams.

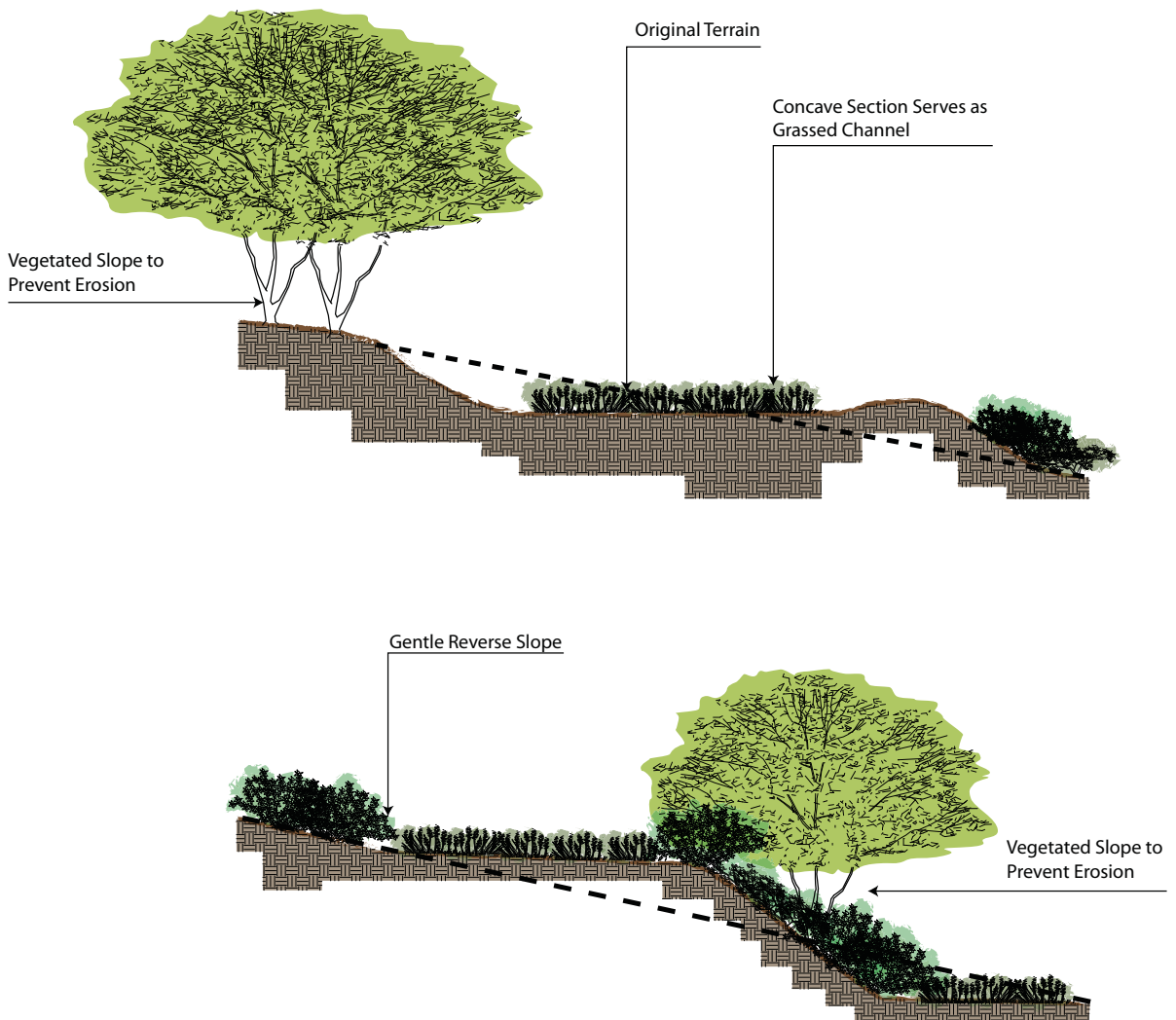

SHORELINE RESTORATION AND STORMWATER MANAGEMENT

Rehabilitation of New York City’s waterfronts to provide public access and amenities is an important opportunity to restore and enhance aquatic and shoreline ecology. Water quality in the receiving waters (streams, rivers, estuaries) is restored when the sources of pollution carried by stormwater are controlled. Physical habitat associated with shorelines cannot readily renew itself, thus human intervention is needed. Design of these features will require the input of specialists including ecologists, marine engineers and landscape architects. Specific opportunities exist in the following site conditions:

- Coves and protected waterfront areas with existing soft substrates (deposited soils) lend themselves to intertidal or salt water wetland development;
- Depositional areas adjacent to strong currents may be suitable for beaches;
- Deteriorated bulkheads and relieving platforms can be reconstructed as stabilized shorelines using armored stone (rip-rap), if there is sufficient upland area;
- Existing piles (with or without pier structures) can be used to enhance aquatic habitat through the use of artificial reef elements;
- Degraded, unstabilized shorelines offer opportunities to create salt water marshes;
- Upland areas adjacent to shorelines can be planted with native vegetation to restore estuarine habitat.

PLANT MATERIAL FOR BIOENGINEERING TECHNIQUES

The role of plant species in surface stormwater control facilities is to bind nutrients and other pollutants by plant uptake; to remove water through evapotranspiration; and to create pathways for infiltration through root development and plant growth. A diverse plant community structure is preferred to avoid monoculture susceptibility to insect and disease infestation. A layered planting scheme that includes canopy and understory trees as well as shrubs and ground covers below, will discourage weeds and will create a suitable microclimate for beneficial microorganisms and other fauna. Plant species must be selected for their tolerance to wide fluctuations in soil moisture content. Plants for use in stormwater facilities designed to accept runoff from roads, walks and parking areas also must be able to withstand salt. Native and naturalized species should be used (refer to chapter: Maximize Vegetation).

Plants should be selected from categories based on zones of hydric tolerance typically known as 1) “riparian fringe” – plants that are subject to periodic inundation as a result of storms and are capable of withstanding short periods of saturated soil; 2) “floodplain terrace” – plants subject to inundation by floodwaters that recede in 24 hours or less and have the capability to stabilize slopes; 3) “upland slopes” – plants that are seldom or never inundated and have the capability to thrive on natural rainfall. Refer selected plant list in the Resources section at the end of this chapter. Basic design criteria for planting:

- Plant trees and large shrubs at least 15 feet away from perforated underdrain pipes;
- Protect underdrain pipes with a gravel layer and geotextile; fabric to prevent roots from infiltrating the underdrain;
- Trees should be planted primarily along the perimeter of bioretention facilities;
- Plant material layout should mimic natural conditions in terms of shade, spacing and layering;
- Provide slope stabilization on slopes greater than 2:1 methods include erosion control mats, seed mixes with fast germination rates, biodegradable mulch mats;
- Use low maintenance ground covers and herbaceous plants in lieu of turf;
- Do not obstruct maintenance access with trees and large shrubs.

TREES AND TRANSPIRATION

A mature tree can transpire between 50 to 300 gallons of water per day, thus acting as an effective stormwater control element.

BERMS

A berm is a constructed mound of earth perpendicular to the downhill flow of water used to intercept and slow overland flow, thereby reducing erosion and encouraging infiltration. Berms can be cost effective in instances where a project will generate fill from excavation. Basic design criteria:

- Minimum height: 12"
- Side slopes" 1:3 recommended. Steeper side slopes may result in erosion and sedimentation if not properly vegetated and maintained
- Minimum length: no minimum but needs to be of sufficient length to span the perpendicular distance of overland flow to be detained and create an aesthetically pleasing form.

DESIGN OF BIOENGINEERED TECHNIQUES

In general, design of stormwater runoff measures requires knowledge of civil engineering and training in landscape architecture. It is recommended that either or both of these disciplines be engaged in the planning and design process. To integrate the types of bioretention techniques described in this chapter into a site design, the following baseline information is needed:

- Knowledge of soil types (sieve analysis)
- Results of soil tests (percolation, infiltration); infiltration rate must exceed 1.5 inches per hour
- Overland flow and drainage catchment area (tributary area)
- Depth to ground water (must be 2 feet below facility invert)

With that information in hand, the designer should follow the following steps to determine the appropriate techniques for the site conditions, and their characteristics:

- **Site Evaluation:** Evaluate the site's topography and associated drainage patterns. Slopes in excess of 20% do not make good candidates for bioretention facilities. Potential bioretention facilities are most suitable where sub-drainage areas are less than 1 acre. Flows greater than 5 cubic feet per second (cfs) for a 10 year storm event cannot be effectively handled by bioretention alone. If existing soils do not provide proper infiltration rate, imported soils will be required.
- **Siting Bioretention Facilities:** Determine the purpose of the bioretention facility and the design storm to be accommodated. (At a minimum, the designer must use the NYC DEP standard of 5.95 inches per hour.) Determine whether the bioretention is being used for water quality treatment, water quantity control, groundwater recharge as well as habitat enhancement, buffering, microclimate benefits and aesthetic improvements. How these factors interact will help determine the best location(s) for the facilities. Explore alternatives to impervious pavement.
- **Sizing Bioretention Facilities:** Determine the storage volume required to either replicate the pre-development level or that results in zero-runoff. Comply with the regulations and calculations proscribed by NYCDEP.
- **Integrating Bioretention With The Visual Landscape:** Work with existing topography, because typically bioretention facilities are placed at low points of a site or close to the source where runoff is generated. Integrate with the vegetated areas to remain. Avoid grading within these areas. Integrate with visual or physical buffers, setbacks and property line treatments.
- **Integrating Bioretention Within The Site Plan:** Locate facilities away from walks to avoid soil compaction from foot traffic, sediment spill on pavements and contamination of plants from deicing salts. Layout parking and related vehicular circulation with bioretention as a goal. Do not locate bioretention facilities uphill of a basement/foundation wall/retaining wall unless proper measures are taken to collect and divert overflow.

THE GREAT DEBATE: GEOTEXTILES VS. GRANULAR BLANKETS

Many bioretention systems rely on geotextiles to protect underdrains from clogging by fine soil particles. Geotextiles are woven or non woven fabrics, and granular blankets are comprised of well-graded sand and stone. Recent research indicates that granular “blankets” or graded stone/sand filters provide greater porosity and hence less likelihood of premature clogging than geotextile fabrics. Stone for granular blankets should be a rounded stone, well-washed, with a minimum size of ½ inch and maximum diameter of 1 ½ inches. The blanket should have a minimum thickness of 4 inches and a maximum thickness of 8 inches outward from the drain pipe.

Geotextile fabrics are recommended as liners along bioretention facilities adjacent to pavements to direct flow downward, thus preventing lateral water movement and reducing chances for frost heaves. Granular blankets are recommended when surrounding underdrain lines and foundation drains.

STORMWATER MANAGEMENT AND THE CITY

The management of stormwater is subject to many regulations and permitting processes. The key agencies and references to their regulations are listed earlier in the chapter under *Laws, Rules and Regulations*. At this time, many of these BMPs are untested in the NYC environment. Nevertheless, the Mayor’s Office has created an interagency task force for BMP implementation, bringing together relevant City agencies to evaluate BMPs and analyze ways to incorporate them into projects. DEP is committed to evaluating many of the concepts proposed in this chapter and has developed several pilot projects and is gathering data on their effectiveness, as part of the Jamaica Bay Watershed Protection Plan. Information and the Plan are available on DEP’s website.

WATER EFFICIENT LANDSCAPING - KEY ISSUES

A water efficient landscape is created by understanding the interrelationships between soil, plants, topography, solar and wind exposure. The goal is to reduce the amount of water needed to support plant life without jeopardizing the vitality of the plants. In general, the designer should establish water use zones in conjunction with the plant material selection, density of plants and their microclimate.

- Low water use zones are those that require no additional water to maintain new plantings after their period of establishment other than natural rainfall
- Moderate water use zones require supplemental water to plants only in times of drought after the initial period of establishment
- High water use zones require regular supplemental water to plants during the growing season.

Regardless of good planning, all plant material should be considered as requiring supplemental water during their establishment periods. The establishment period is the time during which a plant becomes acclimated to its new environment and begins to grow roots that interact with the surrounding soil. It should also be acknowledged that even after the end of a plant's establishment period, prolonged drought coupled with the urban heat island effect and localized solar and wind exposure may create conditions during which supplemental watering will be required. These conditions may be handled by installing hose bibs for hand watering by with a hose, installing temporary oscillating sprinklers (assuming no Stage 1 or worse drought emergency) using slow release polyethylene watering bags ("gator bags"), or employing other measures that do not rely on use of potable water. Typical establishment periods:

- Trees – one year of establishment per inch of caliper
- Shrubs – two years
- Perennials, grasses and vines – one year
- Seed/turf grass – four to six months

Another aspect of water efficient landscaping is proper placement of plants relative to shade and to heat-generating surfaces. Shade can be created by building mass or from other plants, typically trees. Higher canopy trees can be used to create a microclimate of lower evapotranspiration (moisture loss) for understory and ground cover plants by blocking direct rays of the sun. Shade is also a way to reduce heat build up from hard surfaces (vertical or horizontal) and consequently, water loss from soil or plants. Heat build up from horizontal surfaces is best mitigated with shade. Other techniques include drought-tolerant hedges or vertical screens with heat-tolerant vine cover that serve to direct artificially heated air from damaging more sensitive plants and conserving moisture for those plants.

TECHNIQUES FOR WATER-EFFICIENT LANDSCAPING

Summary – Key Techniques

See text for more detail.

WATER-EFFICIENT TECHNIQUES	APPROPRIATE APPLICATIONS	RESOURCE
Rainwater harvesting	All planted areas	Photo
Drip irrigation	Shrub and ground cover areas	–
Grey water for Irrigation	All types of vegetated areas	–
Plant Selection	Site specific criteria affect selection	Web link
Mulch cover	All plant beds exclusive of mown lawns	Specification
Soil amendment	Salvaged in situ soils	Specification

PRINCIPLES OF SOUND IRRIGATION PRACTICE

The purpose of an irrigation system is to apply supplemental water in the event that natural rainfall is not sufficient. Plant selection, planting soil, topography and solar and wind exposure all influence whether natural rainfall is sufficient.



photo: Mathews Nielsen Landscape Architects

Drip irrigation

DRIP IRRIGATION: A quality irrigation system is designed to effectively distribute supplemental water in a way that maintains healthy plants while conserving and protecting water resources/potable water. The most efficient irrigation system is a drip system. Drip irrigation systems use 30-50% less water than sprinkler systems. Drip irrigation slowly applies water directly to the plants' roots. Water flows under low pressure through emitters placed at each plant. The lines are placed on top of the soil and beneath the mulch layer. A range of controls can make drip systems even more efficient. Available controls include rain sensors that prevent the system from turning on during or immediately after a rainfall, soil moisture sensors that activate systems only when soil moisture levels drop below pre-programmed levels, shut-down controls and zoned systems. Drip irrigation is so much more efficient than conventional sprinkler systems that they have been allowed to run daily even when NYC has been in a drought emergency, when sprinkler use has been seriously restricted.



photo: New York City Center for the Environment

Grey water catchment system

GREY WATER FOR IRRIGATION: Grey water is water that can be used twice. Grey water is defined in the NYC Building code as stormwater, district steam condensate or drain water from office building lavatories. Grey water must be treated to remove grease, fibers and particulate matter, and disinfection is critical for grey water held more than 3 hours. Typically, tanks are used for filtering and disinfection, equipped with an overflow line and backflow preventer. Grey water stored in tanks can be disinfected using ultraviolet light, sand filter, heat, reverse osmosis or chlorine. Filtration systems need to remove health hazards and impurities, as well as compounds that can alter the soil's chemical composition. Grey water used for irrigation must be applied using a drip system only. Spray applications are illegal (refer to NYC Board of Health regulations) and will damage foliage.

Captured rainwater can also be considered grey water and used for irrigation. Collection tanks are sized based on drought statistics and the anticipated water requirements of the project. Filtration is required, using aerobic or anaerobic methods.

PLANT SELECTION: Selecting plants for high and medium water use zones is relatively easy. Practically any plant that will survive New York City's climate can be used in a high use zone. In the medium use area, most plants that form large, deep root systems can survive with watering only during stress periods. Plants for low water areas need more careful consideration. Refer to web links at the end of this chapter, which offer lists of suitable plants for low water use conditions.

Designers and others selecting plants for all three water use zones should seek to use native and naturalized species of the New York region as these are most adaptable to local environmental conditions. Refer to chapter: Maximizing Vegetation.

MULCHING: Mulching is very beneficial in all water-efficient landscape zones. It is essential where no additional watering is planned. Mulches conserve soil moisture by blocking or slowing evaporation at the finished grade of the planting area. They also keep the soil cooler and have the added benefit of reducing weeds that compete for soil moisture. Many materials can be used for mulch. Organic materials are generally considered to be best. These include straw, pine needles, wood chips, shredded bark, seed or nut hulls and composted leaf litter. Rock mulches will control weeds and hold moisture in shady areas but in sunny spots, rocks tend to absorb and release heat over a longer period of time which can increase water loss from plant leaves.

SOIL AMENDMENTS: The better and deeper the soil preparation and amendments, the greater will be a plant's ability to survive. Plants in soils that are shallow or compacted will not be able to develop deep root systems that will allow them to have access to more moisture. Soil improvement can include deep tilling, decompaction, adding materials to change the soil's texture or structure, or the introduction of chemical amendments or organic agents to adjust the soil's pH, fertility, or moisture retention capacity. Refer to chapter: Maximizing Vegetation.

HOUSEHOLD IRRIGATION

According to the American Water Works Association, households that manually water with a hose use 33% less water outdoors as compared with conventional sprinkler systems; households with drip irrigation systems use 16% more water than households with no watering system and households with in-ground sprinkler systems use 47% more water than households with no watering system. www.awwa.org

RESOURCES

SOILS GENERAL

- http://www.ncsu.edu/sustainable/soil/phy_char.html

STORMWATER LAWS, RULES & REGULATIONS

- <http://www.epa.gov/Region2/water/nycshed/protptrs.htm>
- <http://www.dec.state.ny.us/website/docu/toolbox/ms4toolbox/localch34app.pdf>
- <http://www.dec.state.ny.us/website/dow/mainpage.htm>
- http://www.ci.nyc.ny.us/html/dep/pdf/water_sewer/3o.pdf

STORMWATER MITIGATION TECHNIQUES

- <http://www.epa.gov/weatherchannel/stormwater.html>
- http://www.lrc.usace.army.mil/co-r/best_management_practices.htm
- Prince George's County Maryland: The Bioretention Manual
- Jamaica Bay Watershed Protection Plan, Volume 2, October 1, 2007

WATER EFFICIENT LANDSCAPE TECHNIQUES

- <http://www.cenyc.org/openspace/rainwater/system> Rainwater Harvesting Systems – Council on the Environment of New York City
George's County Maryland: The Bioretention Manual

RECOMMENDED PLANT LIST

Selection of Recommended Herbaceous Plants for Stormwater Biofiltration Techniques

1. Riparian Fringe (plants subject to frequent inundation and moist/saturated soils)
 - *Carex vulpinoidea*
 - *Carex laevivaginata*
 - *Carex lurida*
 - *Carex stricta*
 - *Aster puniceus*
 - *Aster lanceolatus*
 - *Eleocharis acicularis*
 - *Lobelia siphilitica*
 - *Iris versicolor*
 - *Mimulus ringens*
 - *Scirpus atrovirens*
 - *Scirpus validus*
 - *Spartina pectinata*
 - *Pontaderia cordata*

2. Floodplain (plants subject to standing water less than 24 hours)
 - *Eupatorium perfoliatum*
 - *Liatris spicata*
 - *Muhlenbergia glomerata*
 - *Lobelia cardinalis*
 - *Panicum rigidulum*
 - *Andropogon virginicus*
 - *Glyceria striata*
 - *Calamagrostis canadensis*
 - *Aster novae-angliae*
 - *Veronia noveboracensis*
 - *Verbena hastata*
 - *Eupatorium perfoliatum*
 - *Eupatorium maculatum*
 - *Solidago rugosa*

3. Upland Slopes (plants subject to short term inundation during a storm event only)
 - *Andropogon glomeratus*
 - *Andropogon gerardii*
 - *Bromus ciliatus*
 - *Chasmanthium latifolium*
 - *Deschampsia cespitosa*
 - *Festuca rubra*
 - *Penstemon digitalis*
 - *Solidago canadensis*
 - *Solidago gigantea*
 - *Thalictrum pubescens*
 - *Panicum virgatum*
 - *Veronicastrum virginicum*
 - *Zizia aurea*

Note: Plant selection is dependent on many factors including soil type, moisture retention, pH, and solar exposure. Planting success requires design and engineering calculations to determine the duration of moisture within the plant root zone.

SAMPLE DETAILS

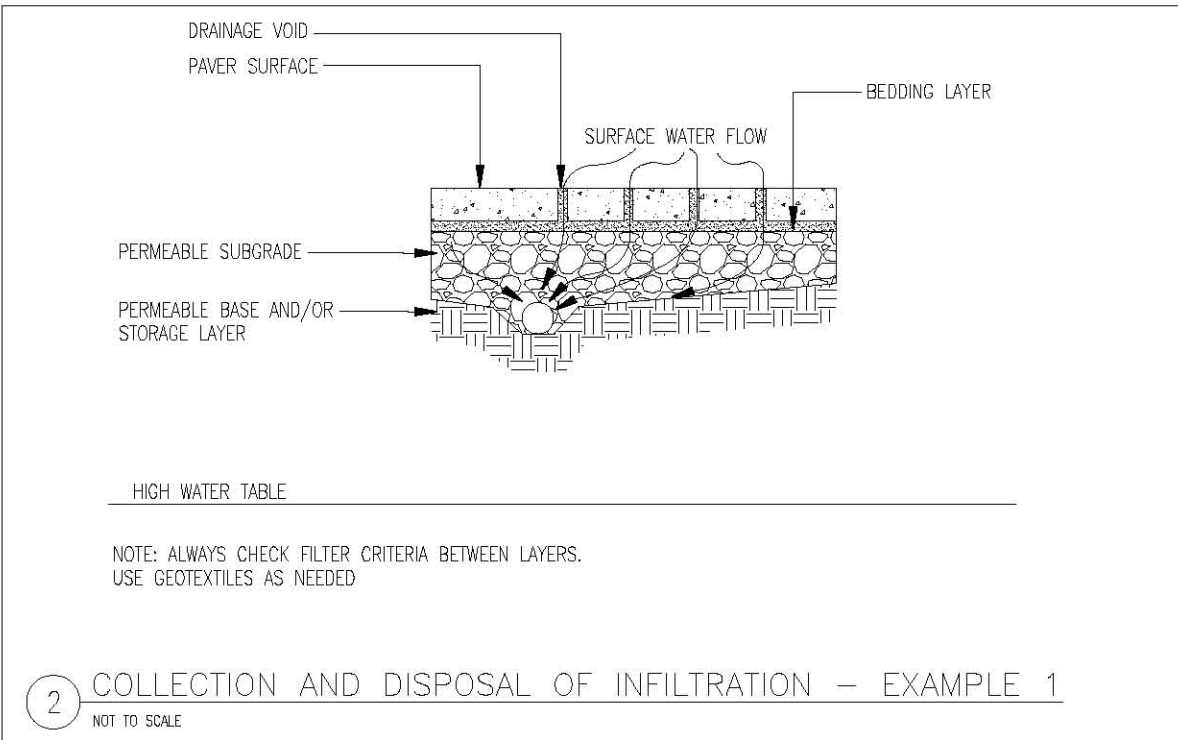
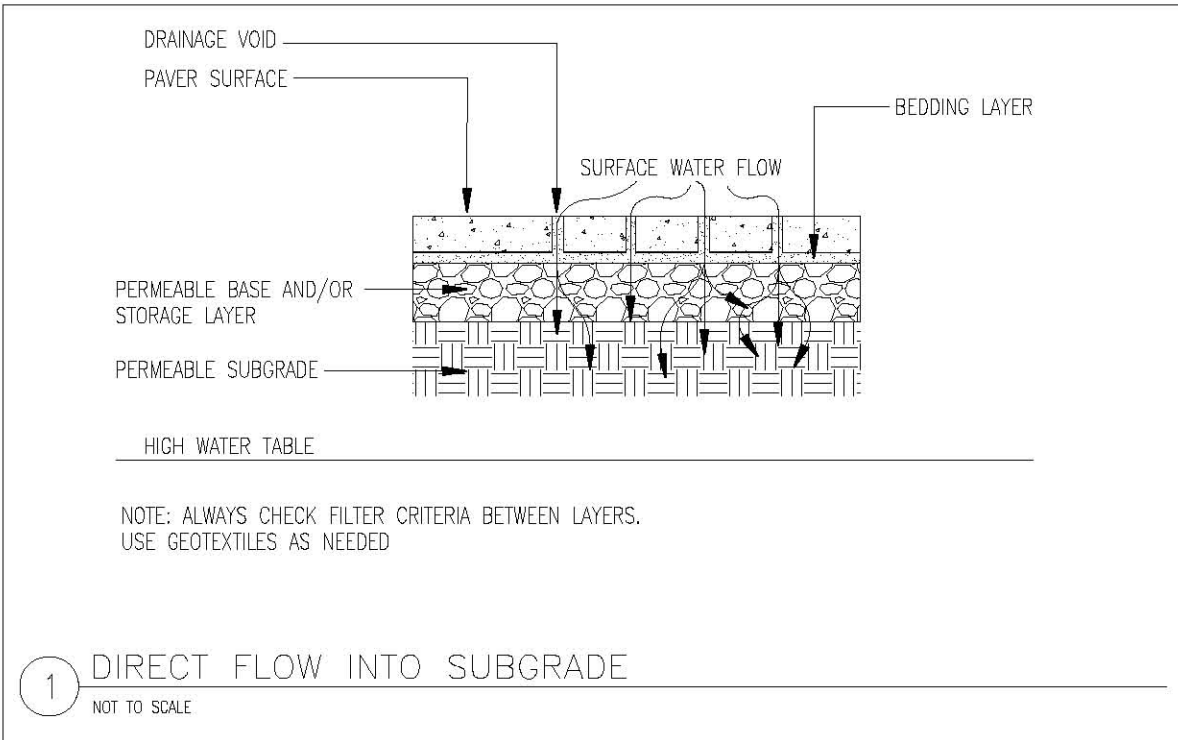

SAMPLE DETAILS

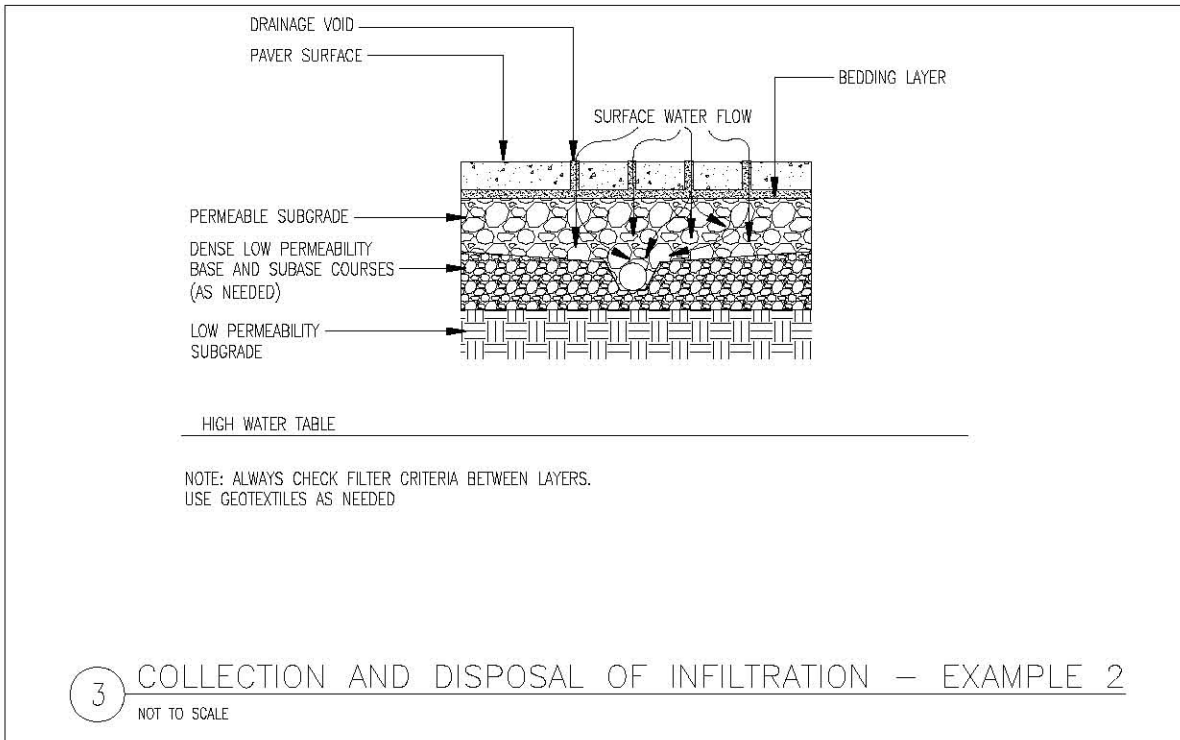



MATERIALS IN SITE
& LANDSCAPE
DESIGN

MATERIALS IN SITE AND LANDSCAPE DESIGN

Although we think of site and landscape design as the use of plants and natural materials, a wide range of products are used to establish and maintain these “natural” features. Additionally, the outdoor environment incorporates walkways, planters, recreational equipment and street furniture.

Light-colored materials for parking, walkways, plazas and other hardscape surfaces reflect heat, helping to mitigate the Urban Heat Island (UHI) effect, as well as making outdoor areas more pleasant in summer. This is an important DDC consideration, especially for those properties with outdoor public areas or on-site parking. Light colored pavements become more effective in reducing the UHI if they can be combined with shade cast from trees or buildings. Additionally, porous and permeable pavements such as stabilized crushed stone or pavers with open joints (planted or filled with aggregate) not only contribute a cooling effect through evapotranspiration of trapped moisture, but also reduce stormwater runoff.

Site and landscape products are available with recycled content, and designers should seek them out when detailing and specifying for the DDC. Sample landscape products that are available with recycled content:

- Planting material – compost, mulch;
- Base material – flowable fill, structural fill, pipe & utility bedding, road base;
- Paving – concrete, pavers, roadway surfaces, wheel stops, resilient surfacing, aggregate substitutes;
- Site furnishings and equipment – planking, decking, tables, benches, play equipment, light poles, plastic lumber, hoses, speed bumps, planters, edging.

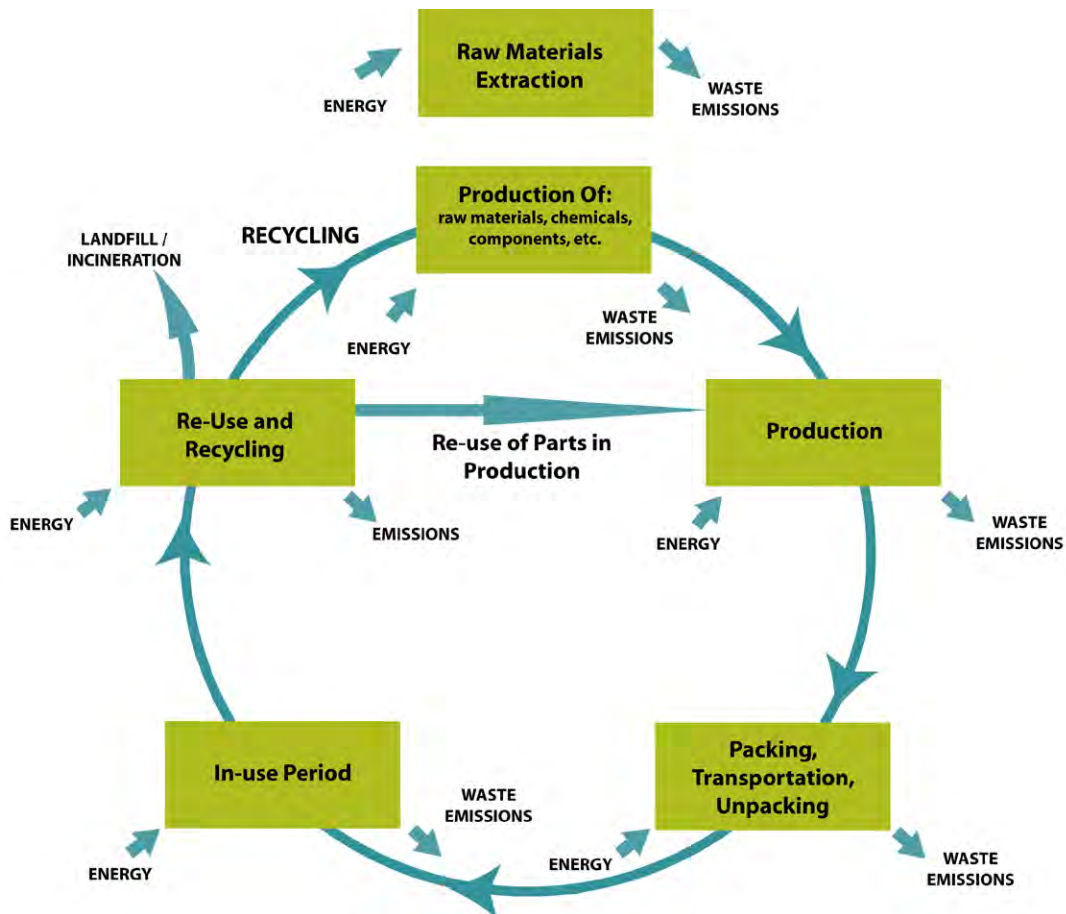

Benefits of using products that incorporate recycled content include diverting waste from landfills, reducing manufacturing waste and pollution, reducing energy consumption, creating jobs, and improving markets for recycled products. Most people are aware that recycling decreases reliance on landfills, incinerators and waste-to-energy facilities. Not only has NYC's Fresh Kills landfill closed, but the number of landfills in the United States has decreased from nearly 8,000 sites in 1988 to 1,654 in 2005.¹ Recycling reduces the need for virgin resources extracted from forests, oil reserves, and mines, saving energy and reducing greenhouse gases, and pollution.

The steps required to supply recycled materials to industry (i.e. collection, processing, and transportation) typically use less energy than the steps required to supply virgin materials (i.e. extraction, refining, processing, and transportation). The majority of the energy savings associated with the use of recycled content materials in manufacturing is the result of avoided processing.

New York City already collects 18 million tons of material for recycling from its residential waste, and the private carters collect more from commercial users. Buying recycled products closes the recycling loop. Unless recycled products are made and used, their collection is useless, and results in large stockpiles of untapped potential resources.

Evaluating the environmental impact of products, whether recycled or new, is called Life Cycle Analysis (LCA), which studies a product for its entire existence – cradle-to-grave, or more appropriately for recycling cradle-to-cradle. Other terms used for this process include Eco-balancing and Material Flow Analysis. The goal of LCA is to combine a minimum input of energy and raw materials with a minimum output of hazardous substances and waste. Starting in the 1960's life cycle analysis models were used to assess the resource cost and environmental implications of human behavior patterns. More recently government regulators have used LCA to formulate environmental legislation, help manufacturers analyze their processes and improve their products.

As a decision-making tool, LCA takes a variety of factors into account including first costs, maintenance costs, expected service life, reconstruction and repair costs, salvage value, disposal and transportation costs, and quantifiable performance characteristics. Because it is quantifiable, LCA results are typically presented as cost comparisons, either as present worth (today's cost) or as equivalent uniform annual cost (annual average over the analysis period). Typical site-related examples of LCAs include evaluation of asphalt or concrete as roadway pavement or deciding whether to conduct full-depth pavement reclamation instead of more frequent, smaller roadway maintenance procedures.

For the individual designer, assessing these relative merits is difficult, more subjective than definitive. As a result, groups undertaking LCA are recognizing that all products have some impact on the environment, and identifying those which are least harmful is an ambitious goal. Cradle-to-cradle assessments, claims and certification programs are beginning to appear, and will only increase as the industry becomes more sophisticated.

RECYCLING SAVES

In 2004, New York State's municipal and commercial recycling programs collected and supplied nearly 18 million tons of scrap commodities (paper, glass, metal, plastics, C & D materials) for use in the production of new products. (Northeast Recycling Council 2004 study).

www.nerc.org

In 2004, New York State's recycling programs saved a total 230 million BTU's of energy, equal to 36% of all energy used by industry in New York State.

www.nerc.org

It takes 90% less energy to recycle an aluminum can than to make a new one.

Every ton of paper that is recycled saves 17 trees.

www.closestheoop.com

LAWS, RULES AND REGULATIONS

SUMMARY – LAWS, RULES AND REGULATIONS

See web links below for more information

AGENCY	LAW, RULES, AND REGULATIONS 2008	APPLICABILITY
NYC (City-wide)	Local Law 121 of 2005 Purchasing Law – Recycled Materials following EPA guidelines	Products covered by EPA Comprehensive Procurement Guidelines
NYC (City-wide)	Local Law 40, Section 431-A, 2006 Yard Waste Composting	Disposal of yard waste, tree pruning and ALB control
NYC (City-wide)	Title 6 Administrative Code “Good Wood Bill” Chain-of-custody requirements	Wood products
NYC (City-wide)	Local Law 37 of 2005 Pesticide Use by City agencies	Pesticide products applied by contractors on City property
US EPA	Comprehensive Procurement Guidelines (CPG)	Guidelines on specific products referenced above
US EPA	Standards for the Use or Disposal of Sewage Sludge (40 CFR Part 503 under the Clean Water Act)	Disposal /reuse of organic and inorganic materials
NYS Department of Environmental Conservation	6 NYCRR Part 360) of Solid Waste Management Facilities: Beneficial Use Determination (BUD)	Disposal /reuse of organic material – biosolids, composting, waste processing
NYS Title 9 Executive Office	Executive Order 142, 1991 Establishing new waste reduction and recycling initiatives for State agencies and maximize procurement of recycled products	Locally available compost, mulch and soil amendments; purchase recycled products ; use NYSDOT specifications for recycled glass and rubber in paving
NYC Finance Law	Finance Law #165 enacted 1991 Prohibits use of specific tropical hardwoods	Tropical hardwoods
NYC Office of the State Comptroller	Finance Article 11, Sections 163 & 165 to allow 10-15% increased discretionary purchasing for recycled or remanufactured products	Products containing recycled or remanufactured content

Web links – Note that regulations not always available on-line.

NYC Recycled Material Purchasing Law

<http://webdocs.nycouncil.info/textfiles/Int%200545-2005.htm?CFID=802996&CFTOKEN=94042437>

NYC Yard Waste Composting Law www.nyc.gov/sanitation

<http://webdocs.nycouncil.info/textfiles/Int%200784-2000.htm>

NYC Pesticide Use Law <https://a816-health12ssl.nyc.gov/ll37/>

US Environmental Protection Agency Comprehensive Procurement Guidelines

<http://www.epa.gov/cpg/products.htm>

US Environmental Protection Agency Sewage Sludge Standards

<http://www.epa.gov/EPA-WATER/1995/October/Day-25/pr-195DIR/pr-195.txt.html>

NYS DEC Beneficial Use Determination

http://www.dec.state.ny.us/website/regs/subpart360_01.html#360-1.15

NEW YORK CITY AND FEDERAL INITIATIVES

In 2005, New York City enacted Local Law 121, which requires the purchase of products with recycled content, tied to the guidelines of the US Environmental Protection Agency. Site-related products specifically mentioned include, composting, hydraulic mulch, garden or soaker hoses, park benches, playground equipment, plastic fencing and others. This local law was amended in January 2007 and is administered by the Director of Citywide Environmental Purchasing. New York City is considering a new law that will strengthen NY State Finance Law #165, to close the loopholes that allow those tropical hardwoods not specifically listed, those for which there is an absence of acceptable alternatives, or those that would encumber a project with a higher cost.

The US EPA updates its **Comprehensive Procurement Guidelines** (CPG) every two years. Through the CPG, the EPA designates items that must contain recycled materials when purchased with appropriated federal funds by federal, state or local agencies. The EPA also issues non-regulatory compliance guidance – the Recovered Materials Advisory Notice – that recommends levels of recycled content for these items. All items designated by the EPA in the CPG are manufactured with materials recovered or diverted from municipal solid waste and materials recovered or diverted from solid waste streams. Once recovered or diverted, these materials are reclaimed and refined, disassembled and remanufactured, or separated and processed for use in manufacturing a new product.

The Environmental Protection Agency reports that the recovery rate for recycled material has been steadily increasing since 1960 and stands at 1.46 pounds per person per day. In 2005, for example, 62% of all yard trimmings were recovered for composting, 21.6% of all glass was recovered, and 35.8% of steel was recovered.²

NYC Department of Sanitation began to conduct an annual Waste Characterization Study in 2004, which surveys the amount and content of recycled materials in domestic trash. Over the course of four seasons between Spring 2004 and September 2005, professional sorters sampled residential and street basket waste. According to this study, waste is everything (including trash and recyclables) that NYC residents put on the curb for collection. The results of this study are that 35.4% of residential waste is recycled. Of that, 22.8% is paper products, 5.7% is metal, 4.3% is glass and 2.1% is plastics.

Beneficial Use Determination (BUD): In New York State, it is critical that a manufacturer or supplier of a recycled product obtain a Beneficial Use Determination (BUD) from NYS Department of Environmental Conservation. A BUD is essentially a stamp of approval from the State that the product or material meets certain baseline criteria, e.g. free from contamination or hazardous content, and that the material is an effective substitute for an analogous raw material. This will allow DDC and designers to substitute recycled-content materials or those remanufactured from recycled materials. For example, BUDs have been granted for the use of foundry sand as aggregate in concrete, the use of gypsum wallboard as a soil amendment and the use of tire chips as backfill material.

<http://www.dec.ny.gov/chemical/8821.html>

DEFINITIONS

RCP: Recycled-content products, made of materials that would otherwise be discarded.
 EPP: Environmentally preferable product
 PCC: Post-consumer content, or material recovered from used products that would otherwise be discarded
 Reuse: Material that would otherwise be discarded is used over again for its original purpose
 Recycling: Use of recovered material in product manufacture.
 Source Reduction: Activity that reduces the amount of material in a product or packaging before that material enters the solid waste management system.

LEED AND SITE MATERIALS

LEED is the sustainable design certification process of the U.S. Green Building Council. One LEED credit is directly related to light-colored paving. In LEED NC Version 2.2, Sustainable Site credit 7.1—Heat Island Effect: Non-Roof offers a credit that can be obtained by using paving materials with an SRI of at least 29, with or without shaded hardscape and/or open-grid paving (this credit can also be obtained by covered parking.)

LEED CREDITS

Materials in Site Design can contribute to the following LEED credits:

Sustainable Site:

Credit 7.1 – Heat Island Effect: Non-roof

Materials and Resources:

Credit MR 2 – Construction Waste Management

Credit MR 3 – Resource Reuse

Credit MR 4 – Recycled Content

Credit MR 5 – Local and Regional Materials

Using recycled materials for landscaping contributes material for meeting Materials and Resources Credit 4: Recycled Content. This LEED credit is applicable to Version NC (New Construction) and Version EB (Existing Building), and requires specific percentages of recycled material, both post-consumer and post-industrial. Using recycled material may also contribute to credit MR 5: Local and Regional Materials, if it is from a nearby source. Reusing or recycling materials from the project's site can contribute to the credit MR 2: Construction Waste Management, because the material is diverted from landfill. And reusing materials without further processing will contribute toward meeting Credit MR 3: Resource Reuse.

LIGHT-COLORED PAVING AND HARDSCAPE

To mitigate the urban heat island effect, paving can be lightened by using concrete in lieu of asphalt, selecting another light-colored material or surface coating, or using lighter color aggregate in asphalt. An alternative strategy is the use of porous pavers with light aggregate fill, which cool by evapotranspiration as well as reflectance.

Paving and hardscape materials are selected to resist the UHI using two criteria: albedo (reflectance) and emittance. Albedo is a percentage scale expressing the ability of a surface to reflect the sun's rays, rather than absorb the solar energy as heat. It is measured in increments from 0 to 1, with 1 being the highest reflectivity index (white surface) and 0 being the highest absorptive index (black surface). New asphalt pavement has an albedo of 0.04; light colored granite has an albedo of 0.54. More and more frequently, manufacturers of paving materials give reflectance values for their products. The higher the albedo the better, because the more solar energy a material reflects as light, the cooler it remains.

Emittance, also a percentage scale, picks up where albedo leaves off, measuring the ability of a material to radiate back to the atmosphere any solar energy it has absorbed as heat. Because emittance is generally considered in concert with albedo, materials are often rated according to the Solar Reflectance Index (SRI), a system that takes both values into account. This single value is critical to sustainable urban site design on projects that feature considerable hardscape surface area. A paving material featuring a high SRI will keep the site significantly cooler than one with a low SRI.

Light colored pavements may be difficult to keep clean, so pressure washing is necessary to prevent the reflectance benefit from diminishing with time. LEED lists the SRI for typical new grey concrete as 35 and weathered grey concrete as 19, but reports that pressure washing can restore reflectance close to original value.

Thickness and conductivity of pavement will affect its ability to counter the UHI effect. Thinner pavements will heat faster during the day but cool quickly at night. Pavement that conducts heat quickly from the surface to a cooler base will retain less heat. Porous pavement stays cool through evapotranspiration and

percolation of water and, in some instances, convective air flow through the voids, cooling base layers, and underlying soil.

Examples of pavements that reduce the Urban Heat Island Effect and possible applications are shown on the table below. ASTM E1980 defines calculation methods for SRI measurement of any material.

LIGHT COLORED PAVEMENT TYPES

PAVEMENT TYPE	APPLICATION	SRI RANGE
Typical new gray concrete	All paved surfaces; Surface reflectivity is affected by color of cement and color of aggregate. Can meet LEED-NC 2.2 Credit SS 7.1	± 35 (per LEED™)
Typical new white concrete	All paved surfaces. Through weathering, surface SRI is reduced to 45. Can meet LEED-NC 2.2 Credit SS 7.1	± 86 (per LEED™)
Light colored pigment or natural concrete	All paved surfaces. Lighter color than standard grey concrete; lighter color aggregate will further lighten. Can usually meet LEED-NC 2.2 Credit SS 7.1	varies
Light colored stone or concrete pavers	Plazas, entries, high visibility areas. Surface reflectivity is affected by color of cement and aggregate. Can usually meet LEED-NC 2.2 Credit SS 7.1	varies
Light-colored loose aggregate	Paths, planted areas. Surface reflectivity is determined by color of aggregate. Possible to meet LEED-NC 2.2 Credit SS 7.1	varies
Stabilized crushed stone	Paths, plazas. Surface reflectivity is determined by color of aggregate. Possible to meet LEED-NC 2.2 Credit SS 7.1	varies
Porous pavers (planted)	Overflow parking areas. Surface reflectivity is affected by color of cement and aggregate. Possible to meet LEED-NC 2.2 Credit SS 7.1	varies
Permeable pavers (aggregate-filled)	Parking, loading zones. Primary benefit is cooling through water filtration. LEED credit does not currently acknowledge this benefit. However Credit SS 7.1 can be obtained if light color paver and aggregate fill are used.	varies
Wood decking (weathered or stained light)	Seating areas. Color is variable and based on wood type and aging. Cannot achieve LEED-NC 2.2 Credit SS 7.1 unless light colored stain or bleaching oil is applied immediately.	varies
Light colored aggregate asphalt (integral)	Roads, parking, service areas. Difficult to meet LEED-NC Credit SS 7.1	varies
Asphalt with light colored aggregate (surface applied)	Access roads, parking, service areas. Reflectivity determined by color of aggregate and thickness to which it is applied. Difficult to meet LEED-NC 2.2 Credit SS 7.1	varies
Light colored coating or synthetic binder coatings on asphalt (surface applied)	Recreation areas, paths. Surface reflectivity affected by binder, aggregate and coating color. Possible to meet LEED-NC 2.2 Credit SS 7.1	varies
Pavers with light colored or reflective exposed aggregates	Plazas, entries, high visibility areas. Surface reflectivity is affected by color of cement and aggregate. Possible to meet LEED-NC 2.2 Credit SS 7.1	varies

STRATEGIES FOR INCORPORATING RECYCLED MATERIAL

First, materials must work well for their intended purpose. For site and landscape design, many recycled products perform very well, and can be specified for DDC projects. Start the consideration of recycled products early, in order to incorporate these products into your project.

PLANNING: SURVEY THE EXISTING SITE

Deconstruction is a term used in green building design that describes the process of carefully dismantling a building in order to salvage the materials for reuse. Deconstruction also can apply to site design. Demolition or land clearing materials may have potential for reuse or on-site recycling. Examples include:

- Concrete pavement (PCC) can be used as recycled concrete aggregate (RCA) and used as base material under new pavements, or temporarily used as construction access routes;
- Asphalt pavement can be milled and reused as recycled asphalt pavement (RAP);
- Stone or brick can be cleaned and reused as units for paving, low retaining walls, curbs or crushed for infilling porous pavements;
- Volunteer trees or trees that must be removed can be chipped on site and reused as mulch in planted areas.
- Reclaimed wood beams/members may be acceptable for edging, planter surrounds, fencing.

DESIGN: TARGET KEY ITEMS

Designers should assess their site components for the potential to use recycled or reused products. The following chart highlights recycled products that are typically available for specific site and landscape uses. Descriptions of these products and suggestions for specifying them are in the subsequent section – organized by the base material, e.g. glass, rubber.

COMPONENT	CONSIDER	NOTES
Parking Lots	Rubber curbs Recycled timber curbs and wheel stops, RAP or RCA or glass or PCC with fly ash as pavement, base or subbase material; glassphalt	Compare options based on first cost and maintenance costs See DDC specification for plastic & wood/plastic lumber
Walkways, Plazas	Glass content in pavers Fly ash in concrete pavers Resilient surfacing or rubber pavement Salvage suitable materials from site demolition	Choices are driven by aesthetics, intensity of use, slope, and first cost and maintenance
Athletic and Recreational Surfaces	Rubber and/or plastic resilient surfacing	See DDC specifications and EPA procurement Guidelines
Planting Beds	Paper, wood or glass mulch Compost Soil amendments Recycled plastics in irrigation/hoses Rubber infill in artificial turf	Selection based on plant material, existing soil, cost and aesthetics
Site Furniture	Fiberglass Plastic lumber for seating or planking Glass content in cast concrete planters Coal fly ash content in concrete planters Aluminum or steel fences with recycled content Plastics in play equipment, signage, fencing, waste receptacles	Selection based on program, aesthetics and cost See DDC specification and EPA Procurement Guidelines for plastic & wood/plastic lumber
Utilities	Glass cullet bedding Coal fly ash in flowable fill Copper or steel pipe with recycled content	Specify products with recycled content
Fill	Coal fly ash Crushed in situ masonry or concrete	Specify recycled content

Reused Products. New York City is continually building, and continually demolishing to make room. In recognition of their value, and in response to the promptings of LEED, usable building materials are being collected from sites in NY and made available for reuse. Possible materials for landscape use include: wood and wood products, railings, exterior light fixtures, organic materials, fill, outdoor furniture and recreational equipment. As of this date, there are two NYC not-for-profit organizations that sell reusable materials or facilitate material exchanges – Wa\$te Match and Build It Green. See Resources. Additional information is available from DDC’s Office of Sustainable Design.

CONSTRUCTION DOCUMENTS: FOLLOW DDC’S REQUIRED SPECIFICATIONS

Performance specifications should be included in the project documents, describing the recycled content requirements as well as the basic performance of the product. Recycled product requirements should be linked to the LEED references in the specifications, and the documentation that the contractor must supply.

According to the DDC’s Design Consultant Guide, August, 2003, if the materials listed below are used in the project, this specification language must be included in the final bid documents.

- 02790 Athletic & Recreational Surfaces
- 03301 Coal Fly Ash in Concrete
- 06511 Plastic and Wood/Plastic Composite Lumber
- NYS DOT Specifications dated May 4, 2006 that permit RCA, blast furnace slag and glass cullet:
- Section 203 Embankments
- Section 300 Bases and Subbases
- American Association of State Highway and Transportation Officials Specifications (AASHTO)
- Compost for Erosion and Sediment Control (MP designation pending)
- Glass Cullet Use for Soil Aggregate Base Course (M 318-01)

CONSTRUCTION PHASE: MONITOR

Follow-through in the construction phase ensures that planned use of recycled materials is not compromised by substitutions, that reused materials are protected and the appropriate paperwork is assembled for LEED submission.

- Review the contractor’s waste management plan to ensure that the targeted site waste reduction goals are met, that the requirements for salvaging and recycling site materials are followed and that protection of planted areas and existing vegetation is in place at the outset of the construction.
- Monitor the contractor’s activities particularly those associated with stockpiling materials, protecting salvaged materials from contamination and keeping existing or future planted areas free from vehicular traffic, stockpiled materials, contamination and protecting them from erosion.
- Ensure that the contractor is providing the proper LEED™ documentation of recycled content, amounts and place of origin.

SPECIFIC TECHNIQUES AND MATERIAL DESCRIPTIONS

Following are typical recycled materials useful in site and landscape design, with their characteristics and suggested uses. They are organized by the component material for a better understanding of performance and availability. Additional products are appearing on the market all the time, and the designers will find this list expanding. **The following are the base materials (feedstock) that are common waste materials in New York, which DDC would like to see recycled:**

- Coal fly ash
- Blast furnace slag
- Plastics
- Rubber
- Glass
- Metals
- Organic Waste
- Asphalt
- Concrete and masonry

MATERIALS AND THEIR RE-MANUFACTURED USES

Base Product (Feedstock)	Typical Site and Landscape Re-Manufactured Uses
Coal Fly Ash	Pipe bedding, flowable fill, concrete, road base, structural and embankment fill, grout, asphalt, concrete block, brick, mortar
Blast Furnace Slag	Slag wool insulation, concrete, asphalt, aggregate subbase
Plastics * (HDPE, PP, LDPE, PET, PVC, PS)	Fencing, piles, site furnishings, play equipment, plastic lumber, edging, wheel stops, traffic cones, speed bumps, garden hoses
Rubber	Edging and curbs, pavements, resilient surfacing, asphalt crack and joint sealant, artificial turf infill
Glass	Pavers, planters, utility bedding, mulch, roadway surfaces and base, fiberglass, sand and aggregate substitute
Metals: Steel, Copper & Aluminum	Fencing, edging, piping, hardware, panels, sign and light poles; irrigation and lawn mowing equipment; reinforcing bars and structural members
Sewage Sludge, Food Waste, Lawn Clippings	Composts
Wood	Mulch, chips for use in recycled lumber
Asphalt	RAP: recycled asphalt pavement, granular base, embankment fill
Concrete and Masonry	RCA: recycled concrete aggregate, paving, porous pavement, granular base, embankment fill
Fiberglass	Planking, decking, tables, benches, wheel stops
Paper	Mulch

Plastics: PET: Polyethylene Terephthalate; HDPE: High Density Polyethylene; PVC: Polyvinyl Chloride; LDPE: Low Density Polyethylene; PP: Polypropylene; PS: Polystyrene.

COAL FLY ASH RECYCLED

Typical Products: Flowable fill Structural concrete

Coal fly ash is a by-product of burning coal to produce electricity and is classified as a pozzolanic material. Fly ash serves as a replacement for a portion of the cement in concrete products and therefore reduces the first cost and environmental costs of cement production. The use of coal fly ash has a number of advantages including making concrete flow and pump better, fill forms more completely and requiring 10% less water in the mix. Concrete using fly ash is denser and more resistant to freeze-thaw than concrete made only with cement.

Coal fly ash should not be used as embankment fill due to its heavy metal content (barium, chromium, lead, aluminum, zinc, and mercury) which can leach into the soil and groundwater at concentrations that can be hazardous to human health and the environment.

Flowable Fill: Flowable fill is a low-strength material that is mixed to a wet, flowable slurry and is used as an economical fill or backfill material. Flowable fill is also designed to support traffic without settling and still have the ability to be readily excavated at a later date. The basic composition is a mixture of coal fly ash (95%), water, coarse aggregate, and Portland cement. It is mixed to support a load of 50 to 100 psi, gains strength in 20 minutes, and is also self-leveling. It is particularly useful for backfill in utility trenches, building excavations, bridge abutments, foundation subbase, pipe bedding, filling abandoned utilities and voids under pavements.

Concrete: Coal fly ash is a common ingredient in concrete specified today, substituting for a portion of the Portland cement previously used. DDC's specification for concrete requires a minimum of 15 % fly ash content.

BLAST FURNACE SLAG RECYCLED

Blast Furnace Slag is a by-product of metal manufacturing that can be crushed and screened for reuse. It has been used as an aggregate material by NYSDOT and other transportation departments nation-wide for more than 50 years. Slag is durable and lighter in weight than stone. Its key advantage is that blast furnace slag compacts readily during installation with minimal rutting during placement and compaction. It offers many of the same advantages as coal fly ash including lighter weight than conventional aggregate and improves pavement stability.

Disadvantages of blast furnace slag include its corrosion-inducing potential and therefore should not be placed adjacent to steel. As a result, NYSDOT has discontinued the use of blast furnace slag in asphalt and concrete.

PLASTICS RECYCLED

*Typical Products: Plastic lumber for site furniture, wheel stops/curbs, etc.
Athletic/recreational surfacing Irrigation and hoses*

Oil and natural gas are the major raw materials used to manufacture plastics. The plastics production process begins by heating components of crude oil or natural gas which results in the conversion of these components into hydrocarbon monomers such as ethylene and propylene. Further processing leads to a wider range of monomers such as styrene, terephthalic acid and many others. These monomers are then chemically bonded into chains called polymers that yield plastics with a wide range of characteristics and properties.

The majority of plastics are thermoplastic, meaning that once a plastic is formed, it can be heated and reformed repeatedly. This property allows for easy processing and facilitates recycling. The advantages of recycled products made from plastics include resistance to chemicals, good thermal and electrical insulation capability, good flexibility and compressive strength, generally light weight and resistant



Plastic lumber bench

to decay, rot, splintering, rust, corrosion or other deterioration typically associated with natural products or metal.

Some of the major limitations to the use of recycled plastic products include poor stiffness (modulus of elasticity) and higher levels of creep as compared to natural wood.

Recycled plastic products can be extruded, injection molded, blow molded or rotationally molded allowing them to be formed into a diversity of shapes ranging from tubes, sheets, or bars. Color can be readily integrated into the shapes avoiding the need for repainting. Most products are themselves recyclable as a result of the basic plastic production process.

Plastic Lumber: Plastic lumber is made from recycled

HDPE generated either by post-consumer or post-industrial waste. The plastic is washed, ground and mixed with colorants, rice hulls, wood chips or other additives and UV stabilizers to be processed into high quality dimensional lumber. This is an arsenic-free material with a service life in excess of 50 years. Plastic lumber will not warp, splinter or rot and is resistant to most chemicals and acids. Plastic lumber does have a higher thermal conductivity than wood, .50 versus .14 Btu in/hr ft °F, however it is still significantly less than steel at 16 or cast iron at 55 Btu in/hr ft °F. Plastic lumber is specified using several ASTM standards.

Fiber Reinforced Lumber: Due to plastic lumber's tendency to deflect under minimal loads, reinforced plastic lumber is now available. The reinforcement is made from fiberglass, which itself can be made from recycled glass.

Structural Grade Plastic Lumber: Plastic lumber products represent a significant and growing end-use for recycled plastics in the US. However, a major limitation is that much remains non-structural and cannot be used in load-bearing applications. In 2006, studies were undertaken to develop ASTM standards and specifications for structural grade recycled plastic lumber. To date, seven ASTM standard specifications have been published and an additional two are in the final stages of development. These specifications address the broad range of applications for structural grade plastic lumber, from decking to pilings. Reference: NYS Environmental Investment Program.

RUBBER RECYCLED

Typical Products: Rubber chips
Traffic controls
Rubber sidewalks

*Rubber edging / curbs
Pavers and matting
Rubberized asphalt*

The most common source for recycled rubber is used automobile tires. Shredding of scrap tires produces chunks of rubber ranging in size from large shreds (12 inches long) to small chips (1/2 inch) and can be used in a variety of products. Favorable engineering properties are that they are light weight, free-draining, impose lower lateral pressure than conventional backfill, and their source is in ready supply.

Disadvantages of using material or products made with a high percentage of recycled rubber are combustibility and the resultant degradation to air quality as a result of the smoke. Other problems include potentially unacceptably high levels of aluminum and mercury that can leach into surrounding soils and ground water.

At this time, the NYC Department of Parks and Recreation is holding off on the use of recycled tires in athletic surfaces until studies prove or disprove concerns over their carcinogenic potential.

Rubber Chips: Recycled rubber chips have a variety of uses including infill in artificial turf, surfacing for volleyball courts, rock climbing areas and walking trails. The source material is usually scrap tires, however, sneakers are popular as crumb rubber infill in artificial turf. The advantages of using rubber chips include good shock absorbing capability, low moisture retention and durability. Disadvantages are primarily associated with heat gain and aesthetic concerns.

Rubber Timbers and Curbs: These are interlocking units (up to 6 feet long) made from 100% recycled rubber. They can be laid to form curves and are useful as edging in landscapes or playgrounds. The timbers and curbs have a rounded top profile and can be laid directly on grade and held in place by means of stakes. The rubber timbers are free from arsenic, can be easily relocated, will not be damaged by trimmers or mowers and will outlive comparable edging made from wood, steel or aluminum.

Rubber Traffic Controls: Recycled rubber tires can be used to form a variety of shapes that are particularly useful in traffic control. Products include speed humps and bumps, parking lot wheel stops, curb ramps, and traffic sign bases. The advantages of these materials include their modular design allowing for ease of installation, removal and relocation, all-weather durability, and resistance to temperature extremes.

Rubber Pavers and Matting: Pavers made from small rubber shreds are shock-absorbing rubber mats typically 24 inches square, which are useful in applications where resilience and accessibility are required. A similar product is poured-in-place resilient surfacing, comprised of a two-layer system. The top layer is made of colored rubberized granules and a polyurethane binder overlaid on another layer of shredded rubber and polyurethane binder. Applications for these materials include: playgrounds, decks, exercise areas, jogging tracks, golf course cart paths, pool decks, skate parks and ice rinks. The pavers and matting are made from 100% recycled rubber, typically scrap tires. Colors can be both solid and flecked. The mats can be laid on a rigid base such as concrete or asphalt, or laid directly on an aggregate base depending on loads and subbase conditions. Mats come as interlocking or butt joint paver units and must be specified by thickness based on the anticipated fall height. Most manufacturers have Consumer Product Safety Commission (CPSC) ratings for child safety and meet Americans With Disability Act criteria.

RUBBER TIRES

People in the United States throw out 290 million tires per year. www.closestheoop.com

It takes 7 gallons of crude oil to produce one car tire. www.isri.org

In 2003, 45% of scrap tires were used for fuel, 20% were recycled in engineering projects and 8% were converted into ground rubber and recycled into products. The remainder were used in rubber-modified asphalt paving or exported. www.epa.gov



Plastic lumber wheel stop

Photo: West Coast Rubber Recycling

Rubber Sidewalks: Rubber sidewalks are made from interlocking modular recycled tires and rubber that are bound together with a urethane resin and a colorant. This results in a high-density paving tile that has a high coefficient of friction for skid resistance under both dry and wet conditions. The material is in compliance with ADA. The pavers are joined together with self-gripping dowels that create a solid body, which neither shifts nor allows individual units to pop-up. This is a recent product development so the life expectancy is not yet known but is expected to exceed 12 years, based on manufacturer's test results. Sizes are 2' x 2' or 2' x 2.5' and weigh approximately 11 pounds per square foot. Colors are available in grey, terra cotta and black. Rubber sidewalks have been installed in New Rochelle, NY, in addition to multiple locations in California, where facilities for milling tires are near the source of discarded tires. For DDC projects, these sidewalks are best considered for on-site walkways, because the NYC Department of Transportation has standard specifications for public sidewalks. The advantages of rubber sidewalks include ease of reinstallation in the case of utility repairs, reduction in tripping hazards resulting from uplifting from freeze-thaw or tree roots, associated costs from trip-and-fall law suits, shock-absorption and reduction in waste going to landfills as a result of sidewalk replacement.



photo: Mathews Nielsen Landscape Architects

Rubber safety surface for recreation

The disadvantages are that rubber sidewalks cost approximately one-third more than concrete and have less flexibility in coloration and joint patterns. It is also likely (based on wear patterns exhibited in safety surfacing) that heavy foot traffic will cause uneven wear patterns. While the rubber is resistant to de-icing salts, other harsh chemicals may damage or discolor pavers.

Rubberized Asphalt: One of the older markets and uses of crumb rubber is as an addition to asphalt, called rubber-modified asphalt. The crumb rubber can be used as part of the asphalt rubber binder, seal coat, or sealant for cracks and joints. Noise studies conducted in California indicate that roads paved with rubber-modified asphalt are significantly quieter than those paved with conventional materials. (www.rubberizedasphalt.org)

GLASS RECYCLED

Typical Products: Glass-content pavers
Reflective paint
General backfill
Drainage
Filtration media

*Glass mulch
Glassphalt
Utility bedding/backfill
Soil
Abrasive blasting*

Most of the glass recovered in the United States (69%) is used by container manufacturers to make new glass bottles and jars. However, in order for this post-consumer glass to be accepted by the manufacturers, it must be free of most "color contamination", thus limiting the amounts that communities and private

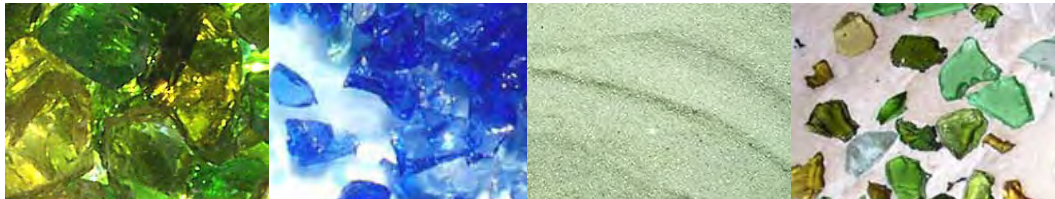

recyclers can sell to such plants. Seventeen percent of mixed broken glass is recycled for use in roadway construction, fiberglass, and landscape applications and 14 % is used for refillable bottles.³

New York City has lots of glass from its recycling efforts (89, 648 tons annually), but 80% of it is color

contaminated (72,228 tons annually). Therefore it is not commercially useful for new glass containers, but available for several uses in landscape applications.⁴

Glass is a relatively new construction aggregate material. In general, glass aggregate is durable, strong, easy to place, and easy to compact. For each application cited below, the material should be specified based on the cullet content (glass pieces are called cullet), gradation, debris level, and compaction level. Depending on the application, specifications may require that processed glass be blended with natural aggregate to a specific percentage. Tests have demonstrated that glass cullet of ¼-inch or less has a grain size close to that of fine-to-coarse sand and glass cullet of ¼-inch or greater is similar to fine-to-coarse gravel.

Glass cullet over 1 inch in size is susceptible to breakage and chipping and is therefore not recommended. A limitation to the use of glass is the amount of debris that may be present in its reuse. Debris may be defined as any material that may impact the performance of the engineered fill if present in sufficient quantities. For glass cullet this can include paper, metals and sugar that adhere to the glass originating from the original product. For example, a debris level of 5% is acceptable for recycled glass applications as pipe backfill but a 10% level is acceptable for retaining wall backfill.



Recycled Glass Pavers

Compaction levels for glass are typically specified using maximum dry densities determined in the laboratory. For applications using 100% cullet, the compaction data is found using a Standard Proctor test (ASTM D698). For glass-soil or glass-aggregate mixtures, a Modified Proctor test (ASTM D1557) is typically used. Compaction levels should be field-verified by in situ testing using a frequency of one test per 2,500 square feet of fill.

Glass Pavers: Glass pavers are manufactured for exterior applications and use approximately 25 % recycled glass content by volume. Glass can also be used in interior surface applications such as monolithic terrazzo floors and unit tiles. They meet slip resistance test of NYCDOT and have a 7,000 – 8,500 psi.

Glass Mulch: Crushed, graded recycled glass can be an attractive ground cover or plant mulch. Specify recycled glass that has been “tumbled” as opposed to “crushed”, which produces a glass that is cubical or autogenous shape. Specify sizes between 3/8 inch to 3 inches Do not use pieces smaller than those that pass a 100 mesh sieve; otherwise they will become airborne dust. Color choices include amber, blue, clear, red, green, and white. Demand for glass mulch has increased to 56,000 tons per year⁵. To calculate quantity: Area in SF x Depth of mulch (usually 2 inches) x 7 = Pounds of Glass Mulch required.



Recycled glass mulch

4 Clean Washington Center (CWC) Best Practices in Glass Recycling
http://www.cwc.org/glass_bp_list.htm

5 New York State Environmental Investment Program

Reflective Glass Paint: Recycled white glass beads that are mixed with paint to produce “reflective marking paint” used in crosswalk and roadway striping. A local plant in Jamestown, New York recovers and sells over 600 tons per year of glass beads.

Glassphalt: Glassphalt is conventional hot-mix asphalt that substitutes glass cullet for 5 % to 40 % of the rock and/or sand aggregate. Glassphalt was originally developed as an alternative to landfill disposal of mixed color waste glass, which cannot be recycled for producing new glass containers. When properly installed, glassphalt does not damage vehicle tires. Glassphalt surfaces dry faster than traditional paving after a rain because glass particles do not absorb water. Glassphalt surfaces are more reflective than conventional asphalt, and also have a slightly lower skid resistance than that of conventional asphalt.

New York City Department of Transportation has discontinued the use of glassphalt on public streets, because of performance issues and health concerns related to the milling process. However, its recycled content and decorative qualities merit its consideration on urban sites, for walkways and parking areas (especially as a base course material).

GLASS BEDDING, BACKFILL AND DRAINAGE APPLICATIONS

New York, Washington State, Oregon, California, Connecticut, and New Hampshire Departments of Transportation permit the use of glass cullet in various roadway construction applications. New York State DOT allows glass cullet for embankment aggregate to contain up to 30% by volume. Roadway subbase may contain up to 30% by weight of glass cullet.

Roadway Applications: Roadway applications include the use of glass cullet aggregate in base course, subbase, subgrade and embankments. Model specifications are:

Applications	Maximum Cullet Content (%)	Maximum Debris Content (%)	Minimum Compaction Level (%)
Base Course	15	5	95
Subbase	30	5	95
Embankments	30	5	90

General Backfill: General backfill applications for glass cullet include those that support heavy stationary loads such as footings and slabs, fluctuating loads such as pumps and compressors, and non-loaded conditions such as landscape fill or sidewalk base course. Model specifications for these applications are:

Applications	Maximum Cullet Content (%)	Maximum Debris Content (%)	Minimum Compaction Level (%)
Stationary Loads	30	5	95
Fluctuating Loads	15	5	95
Non-Loading General Fill	100	10	85

Utility Bedding and Backfill: Utility applications involve the use of glass cullet aggregate for trench bedding and backfill. The model specifications below assume the utility trench is NOT subject to surcharge loading:

Applications	Maximum Cullet Content (%)	Maximum Debris Content (%)	Minimum Compaction Level (%)
Water & Sewer Pipes	100	5	90
Electrical Conduit	100	5	90
Fiber Optic Lines	100	5	90

Drainage: Drainage applications of glass cullet include use for retaining wall backfill, footing drains, drainage blankets, and French drains. Model specifications for these applications are:

Applications	Maximum Cullet Content (%)	Maximum Debris Content (%)	Minimum Compaction Level (%)
Retaining Wall	100	5	95
Footing Drain	100	5	95
Drainage Blanket	100	5	90
French Drain	100	5	90

Soil: Crushed bottle glass has been tested for use as a hydroponic rooting medium. Glass particles range from sizes passing a #8 to a #4 U.S. sieve. The results of one experiment suggest that crushed glass will not negatively affect plant growth. A related test examined replacing sand used in manufactured topsoils that are comprised of 50% sand. The most promising results in terms of plant rooting and growth suggest that substituting 30% of the sand with crushed glass would produce plants of equal or greater growth size compared to plants grown in standard topsoil mix that uses 50% sand.⁶

Crushed Glass as Sand Media for Filtration: Recycled glass has been tested and approved for use as an effective filtration medium, as a substitute for natural sand in recirculating water and pool filters. Post-industrial glass obtained from windows and doors has proven most effective because these are completely free of potential organic (sugars, label, etc) and inorganic (aluminum rings, steel caps, etc.) contamination that can be present in post-consumer container glass. Tests have been conducted by Pennsylvania State and San Jose State Universities as well as the Clean Washington Center.

METALS RECYCLED

Typical Products: Most steel and aluminum products

The most frequently recycled metals in the United States are aluminum, copper, steel, and zinc. Each of these metals can be recycled repeatedly and there is a high demand for products made from processed metal scrap.

The majority of recycled aluminum is used to remanufacture aluminum cans or die casts for automotive parts. Due to this demand, only 13% finds its way into building materials. However, remanufactured aluminum is used in such site construction products as furniture, fencing, hardware, and component parts for irrigation equipment and lawn mowers.

Steel is the most commonly recycled metal in the United States. New steel made with recycled material uses as little as 26% of the amount of energy that would be required to make steel from raw materials extracted from nature. Commonly used site materials that use recycled steel are fencing, pipe, furnishings and landscape edging.

Copper is also routinely recycled and has the highest scrap value of any building metal. The scrap is melted down and reformed into a new, appropriate product. This remelting takes only 15% of the total energy consumed in mining, milling, smelting, and refining copper from ore. The average recycled content of all copper products is 44.6%. Copper wire and copper pipe are the most frequent exterior uses for recycled copper.⁷



Recycled Steel Green Screen

Photo: G-Sky

6 *Testing the Use of Glass as a Hydroponic Rooting Medium (No. GL-96-2) and Crushed Glass Cullet Replacement of Sand in Topsoil Mixes.* <www.cwc.org>

7 www.copper.org/innovations/1998/06/recycle_overview.html

Zinc is both the least energy consumptive to produce from raw materials and is the least likely to be recycled. The average recycled content of zinc in building products is less than 9%; very few landscape or site materials are made exclusively of zinc.

ORGANIC WASTE RECYCLED

*Typical Products: Plant-derived compost
Biosolid compost*

Topsoil, whether available on site or imported from elsewhere, benefits from the addition of organic material. Compost is produced from a variety of sources and is useful as an organic amendment for in situ or manufactured topsoil. Compost is made from a number of feedstocks including food processing residuals, manure and agricultural by-products, forest product residuals, biosolids and sewage sludge, yard trimmings and source-separated organic waste.



Photo: Mathews Nielsen Landscape Architects

Soil Inspection

Due to the nature of these feedstocks, it is imperative to have the materials tested. The Test Methods for the Examination of Composting and Compost (TMECC) is the nation's recognized laboratory for establishing benchmark methods for compost analysis. Test are conducted for 1) sampling procedures, 2) physical properties, 3) inorganic chemistry properties, 4) organic and biological properties, 5) synthetic organic compounds and 7) pathogens. The US EPA is in the process of developing a Seal of Testing Assurance (STA) for the commercial composting industry in an attempt to standardize testing protocols and acceptable levels of compost performance.

Plant-Derived Compost: Compost products are the result of biological degradation and transformation of plant-derived materials under controlled conditions designed to promote aerobic decomposition. Sources of this compost include yard waste such as leaf litter, lawn clippings, nut and bean shell and hulls. Suitable composts must be mature, stable and non-erodible. Model specifications list the following requirements:

- Fine compost sieve size: maximum 3% finer than 0.002 mm
- Coarse compost sieve size: 100% passing 3/8 " screen
- pH range: 6.0-8.5
- Inert debris content: less than 5% on a dry weight or volume basis
- Minimum organic content: 40% by dry weight (Loss-on-Ignition test)
- Soluble Salt content: less than 6.0 mmhos/cm
- Full sample specification available: www.metrokc.gov/procure/green/compost.htm

Biosolid Compost: Biosolids are a byproduct of wastewater treatment. After treatment in a wastewater treatment facility, the liquid effluent is typically discharged into a nearby river and the solids are removed from the treatment plant for disposal or beneficial use. Converting municipal sewage sludge into usable compost requires advanced biological treatment of biosolids. The process produces a stable, humus-like material with a low organic content. Another process involves heat-drying the sludge to create pellets. Macronutrients (nitrogen and phosphorous) and organic matter in biosolids are useful for both fine-textured soils (clay) and coarse textures soils (sand). Organic matter can be added to clay soils to make them looser or more friable and can increase the amount of pore space available for root growth. In sandy soils, organic matter can increase the water-holding and nutrient capacity of the soil.

Disadvantages of biosolid compost vary depending on the characteristics of the wastewater entering the wastewater treatment plant and the treatment processes used. Federal, state and local regulations have reduced the types and quantity of pollutants in biosolids; nonetheless, heavy metals, pathogens and

organic chemicals may still be present. These can be used in NYC as long as the compost complies with DEC regulations; NYC defers to DEC on contaminants. DEC defers the US EPA. For more information, go to *A Plain English Guide to the EPA Part 503 Biosolids Rule*, at <http://www.epa.gov/owm/mtb/biosolids/503pe/>.

ASPHALT RECYCLED

Typical Products: Recycled pavement

Recycled Asphalt Pavement (RAP) is milled asphalt and can be used to repair in-situ pavement or to create new pavement from existing asphalt. According to the University of California Transportation Center, about 90% of recovered RAP is reused to make new asphalt pavement. The advantages of using RAP are the reduced use of non-renewable petroleum resources and virgin aggregates. Asphalt made using RAP has a longer life cycle than conventional asphalt because the pavement is more water resistant. Asphalt pavement using recycled asphalt content exhibits similar performance criteria to non-recycled mixes in terms of rutting, raveling, weather resistance and fatigue cracking. Disadvantages include maintenance of quality control over the stockpiles of RAP, availability, and local plant technology, which can limit the amount of RAP in a particular mix. Within New York State, the amount of permissible RAP is 10-30% of the total aggregate content.

There are four types of processes that use RAP:

1. Full-depth Reclamation: All of the asphalt section and a portion of the underlying base materials are processed to produce a stabilized base course. The materials are crushed and additives introduced; the materials are then shaped and compacted and a surface wearing course is applied. Production rates vary from 300 to 1200 square yards per hour.
2. Hot, In-Place Recycling: The pavement is softened by heating and is scarified or hot-milled to a depth of $\frac{3}{4}$ to $1\frac{1}{2}$ inches and mixed. New hot mix material and/or a recycling agent is added with a single pass of the machine. A new wearing course may also be laid with an additional pass after compaction. Production rates vary from 1 to 2 lane-miles per day.
3. Hot Recycling: At a central plant, RAP is combined with hot new aggregate and asphalt or a recycling agent to produce AC, using a batch or drum plant. The RAP is usually obtained from a cold planing machine but could also be from a ripping/crushing operation.
4. Cold, In-Place Recycling: The pavement is removed by cold planing to a depth of 3 to 4 inches. The material is pulverized, sized and mixed with an additive. Virgin aggregate can be added to modify RAP characteristics. An asphalt emulsion or recycling agent is added, and then the material is placed and compacted. According to the Asphalt Recycling and Reclaiming Association, cost savings can range from 20 to 40 percent over conventional techniques.

There are some conditions where the milling and repaving process is cost effective and can be done in one process using either one single machine or a “train” of three specialized machines. This is called in-place recycling which eliminates costs associated with transporting, processing and stockpiling RAP. Advantages to this one-step process include shorter construction time, less disruption to local traffic patterns, cost-effectiveness, and less transportation-related environmental damage. This process may not be appropriate in all conditions as the machines are extremely noisy and may violate local noise regulations. It might be appropriate for large DDC projects that are not in a residential neighborhood, such as Remsen Yard or Harper Street Yard.

CONCRETE AND MASONRY RECYCLED

*Typical Products: Recycled aggregate
Chips for paths/fill*

Recycled Portland Cement Concrete Aggregate (RCA): The most common use of recycled concrete aggregate is as subbase material either alone or mixed with sand, gravel or blast furnace slag. According to NYSDOT standard specifications, to be suitable for this application, RCA must contain 95% Portland Cement Concrete by weight and must be free of metal, wood or other deleterious materials. That means that RCA, by itself, can contain up to 5% sand, asphalt or gravel. Other uses for RCA include riprap, reuse in cement concrete, and as general fill.

The use of RCA or recycled masonry adjacent to waterways or wetlands may require permission from DEC and/or the U.S. Army Corps of Engineers via a beneficial use determination and permits.

Stone, Brick, Masonry Chips: Brick, concrete block, and stone are all sources of material that can be crushed and reused as path material or as fillers for porous pavers. Stone can be crushed even finer into a material known as decomposed granite (DG). When mixed with a binder, stone dust paths and surfaces offer an attractive alternative to monolithic pavements or more expensive unit pavers. An added advantage is that they are somewhat permeable and can be used around trees. The primary limitations are that the small pieces can track or become dislodged by erosion or scuffing.



Photo: Hanover Pavers

Eco-Grid pavers, filled with recycled gravel

RESOURCES

GENERAL

- US EPA Environmentally Preferable Purchasing Database
<http://www.epa.gov/oppt/epp/tools/database.htm>
- Recycled Content Product Directory <http://www.ciwmb.ca.gov/RCP/>
- Northeast Recycling Council, Inc. www.nerc.org
- National Center for Remanufacturing and Resource Recovery www.reman.rit.edu
- NY Wa\$teMatch www.wastematch.org
- Build It Green <http://www.bignyc.org/>
- American Chemistry Council www.americanchemistry.org
- Minnesota Recycled Products Directory <http://www.pca.state.mn.us/oea/rpdir/rpmoreb.cfm>
- Michigan Recycled Materials Market Directory
[http://www.michigan.gov/deq/0.1607.7-135-3312-12387-.00.html](http://www.michigan.gov/deq/0,1607,7-135-3312-12387-.00.html)
- National Recycling Coalition www.nrc-recycle.org
- NYC DDC Construction and Demolition Waste Manual
<http://nyc.gov/html/ddc/html/ddcgreen/reports.html>
- Pennsylvania Resources Council, Inc. www.prc.org
- Eco Companies Directory www.ecofirms.org
- Clean Washington Center www.cwc.org
- Institute of Scrap Recycling Industries, Inc. www.isri.org
- New York State Association for Reduction, Reuse and Recycling www.nysar3.org
- Ecospecifier (lists 3000 environmentally preferable products) www.ecospecifier.org
- NYS DEC list of companies that have been granted BUDs
<http://www.dec.state.ny.us/website/dshm/redrecybudwst.pdf>
- Steel Recycling Institute www.recycle-steel.org
- The Aluminum Association www.aluminum.org

PLASTICS

- www.plasticbagrecycling.org
- Association of Postconsumer Plastic Recyclers www.plasticsrecycling.org
- Plastic Lumber Trade Association

GLASS

- Pennsylvania Department of State. www.depstate.pa.us
- Clean Washington Center www.cwc.org
- North American Insulation Manufacturers Association www.naima.org
- Glass Packaging Institute www.gpi.org

COMPOST

- Kings County Environmental Purchasing department
www.metrokc.gov/procure/green/compost.htm
- The US Composting Council www.tmecc.org
- National Biosolids Partnership www.biosolids.org

ASPHALT

- Asphalt Recycling and Reclaiming Association www.arra.org
- National Asphalt Pavement Association www.hotmix.org
- Federal Highway Administration

COAL AND FLY ASH

- American Coal Ash Association www.aaa.org
- Fly Ash Facts for Highway Engineers <http://www.fhwa.dot.gov/pavement/fatoc.htm>
- Concrete mixes incorporating fly ash
<http://www2.cityofseattle.net/util/engineeringArticleView.asp?ArticleID=9-23.9#9-23.9>
- FHA: Slag use in Portland Cement Concrete
<http://www.tfhrc.gov/hnr20/recycle/waste/begin.htm>
- Slag Cement Association www.slagment.org

PURCHASING LAWS

- NYC Environmentally Preferable Purchasing (EPP) Minimum Standards for Construction Products (Draft)
- NYC Environmentally Preferable Purchasing (EPP) Minimum Standards for Goods (Draft)
- New York City Local Laws 118, 119, 120, 121 and 123, effective January 1, 2007

ACKNOWLEDGEMENTS

The *Sustainable Urban Site Design Manual* is a collaborative effort made by New Yorkers who want to improve our urban sites and make NYC a greener place. Special thanks go to the following individuals for their gracious contributions of time and expertise.

MATHEWS NIELSEN LANDSCAPE ARCHITECTS PC

Signe Nielsen, FASLA
Jessica Osserman
Tricia Martin

GRUZEN SAMTON ARCHITECTS LLP

Susan Drew, AIA LEED AP
Claibourn Hamilton
Jenna Widman

NEW YORK CITY

Laurie Kerr, RA, LEED AP
*Mayor's Office of Long Term Planning
and Sustainability*

Kerry Carnahan
Bruce Hendler, RLA
Department of Design and Construction

Of the following NYC peer reviewers acknowledged, special thanks goes to the Department of Environmental Protection and Law Department contributors, for their patient and thorough clarification of City stormwater regulations and management.

NEW YORK CITY PEER REVIEWERS

Laurie Kerr, RA, LEED AP
Carter H. Strickland, Jr.
Mayor's Office of Long Term Planning and Sustainability

Amanda C. Goad
Hilary Meltzer
Environmental Law Division, Law Department

Magdi Farag
Helen Forgione
Kathryn Garcia
Jim Garin
Angela Licata
Warren Liebold
John McLaughlin
Stacy Radine
David Ramia
Esther Siskind
Julie Stein Kaplan
Constance Vavilis
Department of Environmental Protection

Jen Becker
Len Greco
David Kane
Economic Development Corporation

Deborah F. Taylor, AIA, LEED AP
Department of Buildings

Howard Slatkin
Department of City Planning

Bram Gunther
Department of Parks and Recreation

Wendy Feuer
Michael Flynn
Kedari Reddy
Andy Wiley-Schwartz
Department of Transportation



NEW YORK CITY DEPARTMENT OF
DESIGN + CONSTRUCTION